

PALAZZETTI

IL CALORE CHE PIACE ALLA NATURA

PREMIUM UI
PREMIUM XL



IT

UTILIZZO E FUNZIONALITÀ

Il presente manuale è parte integrante del prodotto.
Si raccomanda di leggere attentamente le istruzioni prima dell'installazione, manutenzione o utilizzo del prodotto.

Istruzioni originali

EN

USE AND FUNCTION

This manual is an integral part of the product.
Read the instructions carefully before installing, servicing or operating the product.

Translation of the original instructions

DE

VERWENDUNG UND BETRIEB

Die vorliegende Anleitung ist fester Bestandteil des Produkts.
Vor der Installation, Wartung und Verwendung die Anleitungen stets aufmerksam durchlesen.

Übersetzung der Original-Bedienungsanleitung

FR

UTILISATION ET FONCTIONNEMENT

Le présent manuel fait partie intégrante du produit.
Il est conseillé de lire attentivement les consignes avant l'installation, l'entretien ou l'utilisation du produit.

Traduction des instructions originales

ES

USO Y FUNCIONES

Este manual es parte integrante del producto.
Se recomienda leer detenidamente las instrucciones antes de la instalación, el mantenimiento y el uso del producto.

Traducción de las instrucciones originales

IT

Gentile cliente,
desideriamo innanzitutto ringraziarLa per la preferenza che ha voluto accordarci acquistando il nostro prodotto e ci congratuliamo con Lei per la scelta.
Per consentirLe di utilizzare al meglio PREMIUM UI - PREMIUM XL, la invitiamo a seguire attentamente quanto descritto nel presente manuale.

EN

Dear Customer,
We'd like to thank you for having purchased one of our products and congratulate you on your choice.
To make sure you get the most out of PREMIUM UI - PREMIUM XL please carefully follow the instructions provided in this manual.

DE

Sehr geehrter Kunde,
Zuallererst möchten wir Ihnen für den uns gewährten Vorzug danken und Ihnen zur Wahl gratulieren.
Damit Sie Ihren neuen PREMIUM UI - PREMIUM XL so gut wie möglich benutzen können, bitten wir Sie, die in dieser Bedienungs- und Wartungsanleitung enthaltenen Angaben genau zu befolgen.

FR

Cher client,
Nous souhaitons avant tout vous remercier de la préférence que vous nous avez accordée en achetant notre produit et vous félicitons pour votre choix.
Afin de vous permettre de profiter au mieux de PREMIUM UI - PREMIUM XL nous vous invitons à suivre attentivement les instructions reportées dans cette notice.

ES

Estimado Cliente,
Deseamos agradecerle por la preferencia que nos ha otorgado adquiriendo nuestro producto y lo felicitamos por su elección.
Para el mejor uso de PREMIUM UI - PREMIUM XL lo invitamos a leer con atención cuanto se describe en el presente manual.

INDICE

1	PANNELLO COMANDI	5
1.1	Descrizione	5
1.2	Descrizione generale delle icone	5
1.3	Albero di navigazione	6
1.4	Schermata iniziale e set temperatura	7
2	OPERAZIONI PRELIMINARI	9
2.1	Caricamento pellet	9
2.2	Alimentazione elettrica	9
3	MENU IMPOSTAZIONI	10
3.1	Impostazioni	10
3.1.1	Impostazione "Ora"	11
3.1.2	Impostazione "Data"	11
3.1.3	Funzione "Combustibile"	11
3.1.4	Funzione "Eco mode"	12
3.1.5	Funzione "Antigelo"	12
3.1.6	Display	13
3.1.7	Funzione "Pulizia"	14
3.1.8	Impostazione "Unità temperatura"	14
3.1.9	Impostazione "Altoparlante"	15
3.1.10	Funzione "Ore residue manutenzione"	15
3.1.11	Menu Installatore	15
3.1.12	Menu di servizio	16
3.1.13	Funzione "Blocco schermo"	16
3.1.14	Lingua	17
3.1.15	Informazioni	17

4 USO	18
4.1 Accensione	18
4.1.1 Modifica della temperatura ambiente	19
4.1.2 Modifica della potenza	19
4.2 Modifica dei parametri	19
4.3 Spegnimento	20
4.4 Riaccensione dopo il black-out	20
4.5 Funzionamento con termostato ambiente	21
4.6 Funzionamento con sonda ambiente a bordo stufa	21
5 FUNZIONI DISPONIBILI	22
5.1 Impostazione timer	22
5.1.1 Abilitazione/disabilitazione timer	22
5.2 Statistiche	23
5.3 Suggerimenti di funzionamento	24
6 ANOMALIE E POSSIBILI RIMEDI	25
6.1 Descrizione allarmi	25
6.2 Reset allarmi	26
6.3 Descrizione avvisi	27
6.4 Reset avvisi	27

SIMBOLOGIE UTILIZZATE NEL MANUALE E LORO SIGNIFICATO



Indicazione: Per indicare informazioni particolari.



Attenzione: Per indicare operazioni particolarmente importanti e delicate.



Pericolo: Per indicare azioni che, se non effettuate correttamente, possono provocare infortuni di origine generica o possono generare malfunzionamenti o danni materiali all'apparecchio.

1 PANNELLO COMANDI

1.1 Descrizione

Il pannello comandi è composto da:

- 1) Ricevitore IR (infrarossi)
- 2) Sensore luce ambiente
- 3) Schermo Touch Screen
- 4) Altoparlanti
- 5) Connettore RJ11

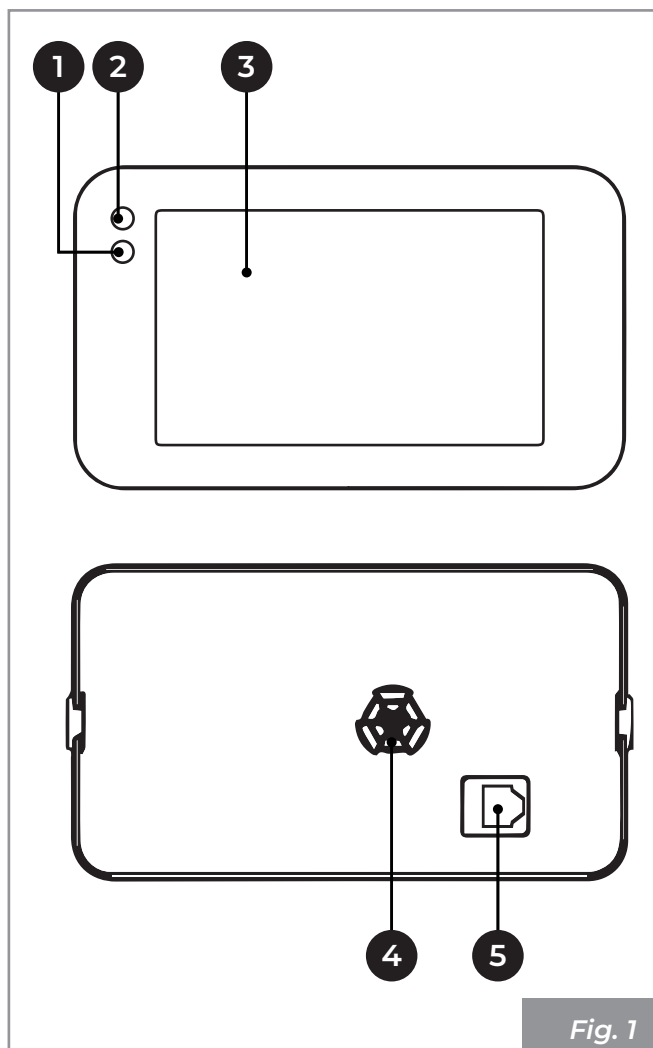

Fig. 1



Indicazione: Lo schermo è di tipo Touch Screen, pertanto non necessita di una pressione per essere attivato, ma è sufficiente sfiorarne la superficie.

1.2 Descrizione generale delle icone

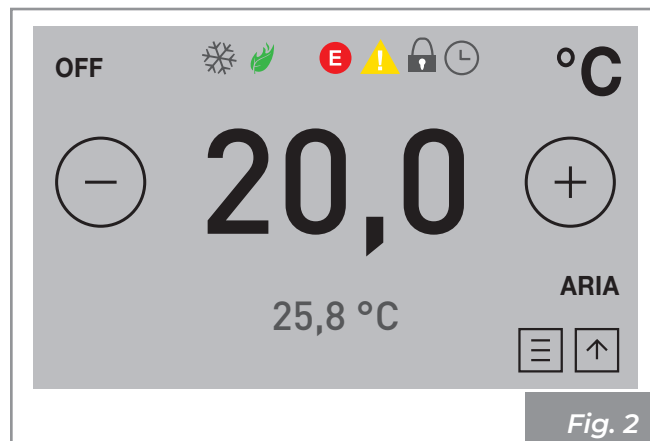

Fig. 2

Icona	Descrizione
	Allarme
	Avviso
	Funzione Eco mode attiva
	Menu principale
	Accensione apparecchio
	Timer attivato
	Funzione "Antigelo" attiva
	Blocco schermo
OFF	Indicazione apparecchio spento
20,0	Temperatura impostata
25,8	Temperatura rilevata dalla sonda

1.3 Albero di navigazione

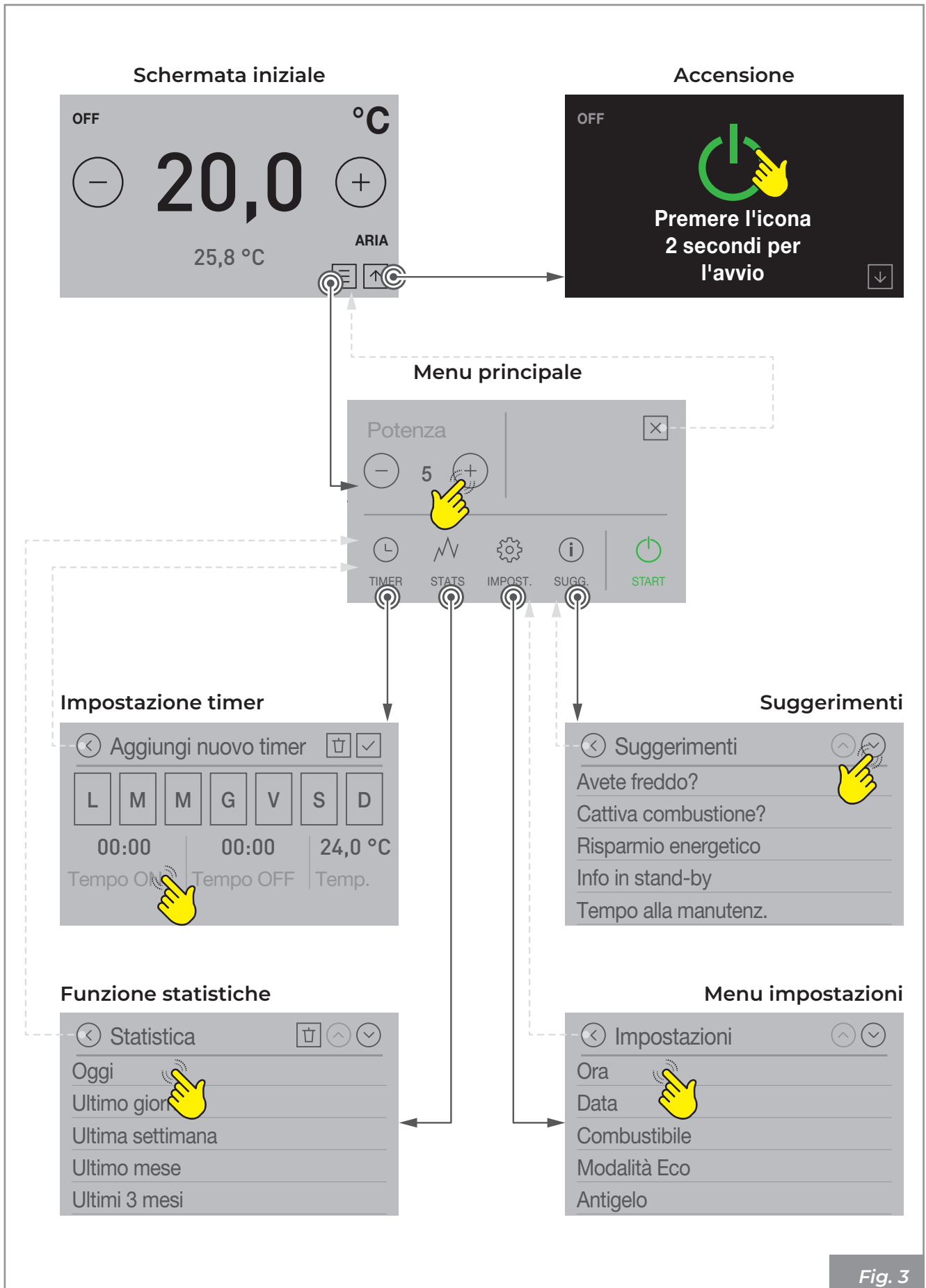

Fig. 3

1.4 Schermata iniziale e set temperatura

In funzione della configurazione installativa dell'apparecchio, si visualizzano diverse schermate iniziali e diversi valori di temperatura.

Configurazione 1 - Termostato ambiente

Schermata iniziale

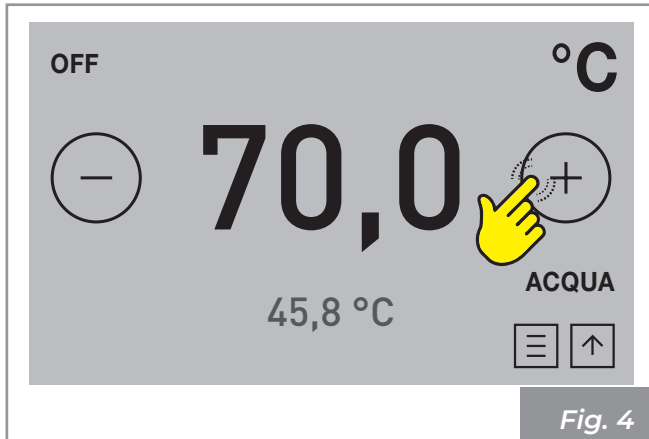

Questa schermata riguarda la temperatura di mandata dell'acqua calda della caldaia.

Premere sulle icone \oplus o \ominus per variare la temperatura desiderata di mandata (digit grandi)
I valori impostabili vanno da 45°C a 80°C.

I digit piccoli visualizzano la temperatura effettivamente rilevata dalla sonda di mandata

Premere su "**ACQUA**". Si passa alla seguente visualizzazione:

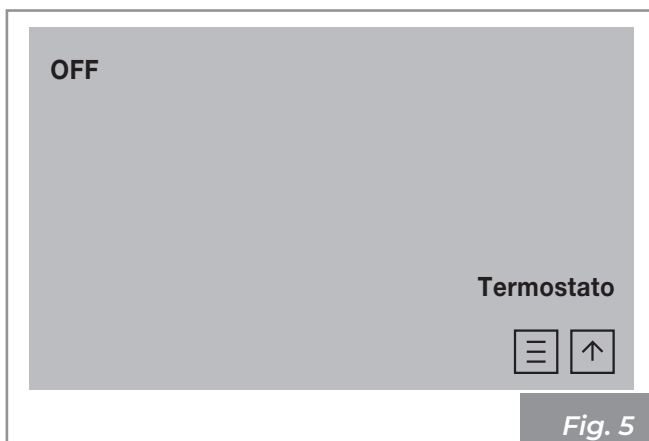

Premere su "**Termostato**" per tornare alla schermata precedente.

Configurazione 2 - Sonda ambiente

Schermata iniziale

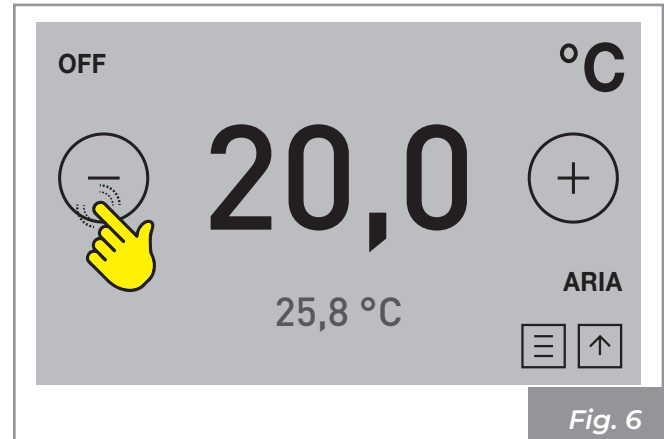

Questa schermata riguarda la temperatura ambiente.

Premere sulle icone \oplus o \ominus per variare la temperatura che si desidera raggiungere in ambiente (digit grandi).
I valori impostabili vanno da 10°C a 40°C.

I digit piccoli visualizzano la temperatura ambiente rilevata da una sonda posta sull'apparecchio

Premere su "**ARIA**". Si passa alla visualizzazione della temperatura di mandata dell'acqua calda della caldaia:

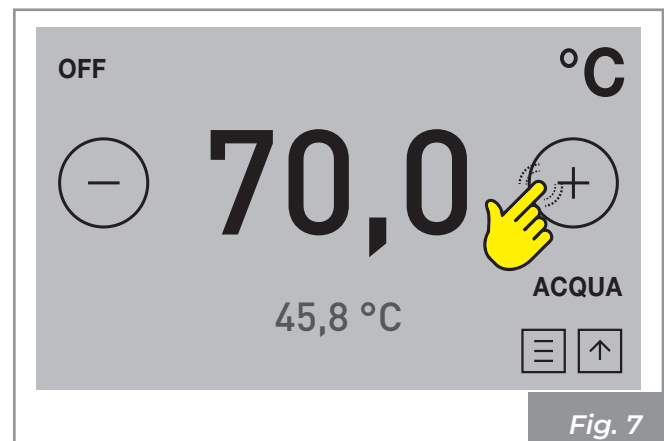

Premere sulle icone \oplus o \ominus per variare la temperatura desiderata di mandata (digit grandi)
I valori impostabili vanno da 45°C a 80°C.

I digit piccoli visualizzano la temperatura effettivamente rilevata dalla sonda di mandata

Configurazione 3/4 - Accumulo con/senza serpentino

Schermata iniziale

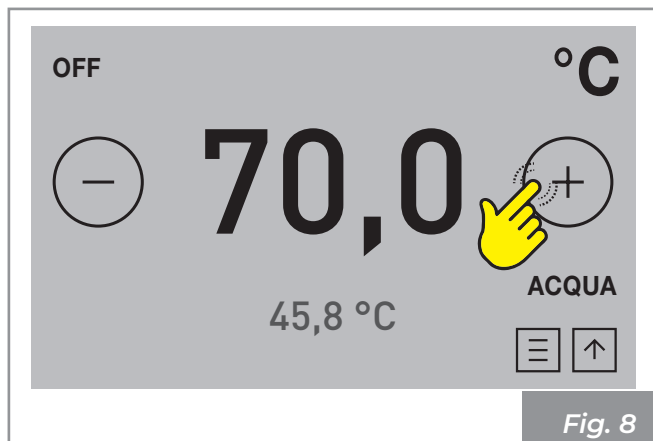

Questa schermata riguarda la temperatura dell'acqua calda all'interno dell'accumulo.

Premere sulle icone \oplus o \ominus per variare la temperatura che si desidera mantenere all'interno dell'accumulo (digit grandi)
I valori impostabili vanno da 45°C a 80°C.

I digit piccoli visualizzano la temperatura effettivamente rilevata dalla sonda presente nell'accumulo.

2 OPERAZIONI PRELIMINARI

2.1 Caricamento pellet

La prima operazione da eseguire prima di accendere il prodotto è quella di riempire il serbatoio di combustibile (pellet) utilizzando preferibilmente una apposita paletta.

Non svuotare il sacco direttamente nel serbatoio per evitare di caricare della segatura o altri elementi estranei che potrebbero compromettere il buon funzionamento dell'apparecchio e per evitare di disperdere il pellet al di fuori del serbatoio.

Indicazione: Assicurarsi di richiudere bene il coperchio del serbatoio dopo aver effettuato l'operazione di caricamento del pellet. Un interruttore di sicurezza "IS" (solo per i modelli dove previsto) ne verifica la corretta chiusura e manda in allarme l'apparecchio se il coperchio viene lasciato aperto per più di un minuto con apparecchio funzionante.

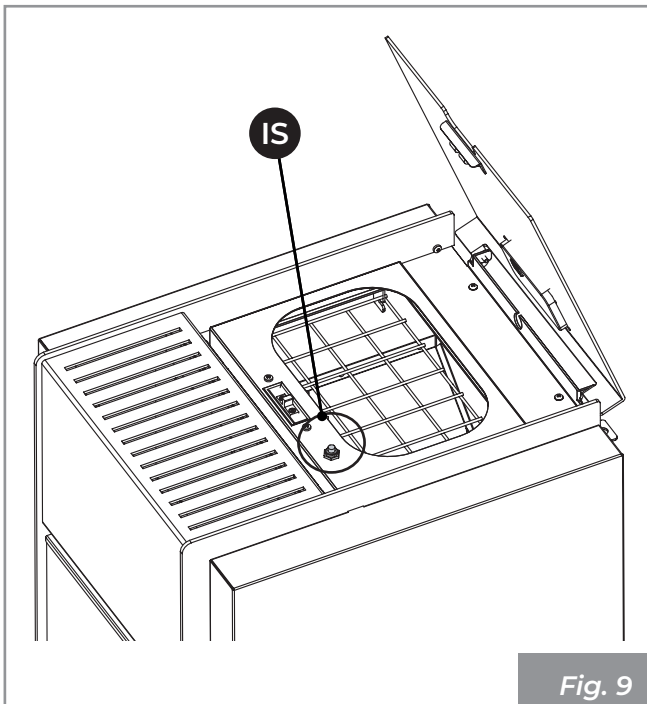

Fig. 9

2.2 Alimentazione elettrica

Collegare l'apparecchio alla rete elettrica, agire sull'interruttore di accensione posto sul retro dell'apparecchio posizionandolo su "I".

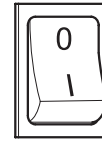

Fig. 10

Se il collegamento è corretto l'apparecchio emette una serie di segnali acustici intermittenti e si accende il display.



Attenzione: Per lunghi periodi di inutilizzo, si consiglia di posizionare l'interruttore sul retro dell'apparecchio in posizione di OFF (0).



Indicazione: Assicurarsi di non toccare il pannello di comando nel momento in cui viene data alimentazione all'apparecchio.

Alimentando l'apparecchio si visualizza il logo iniziale.



Fig. 11

Dopo alcuni secondi appare la schermata iniziale:

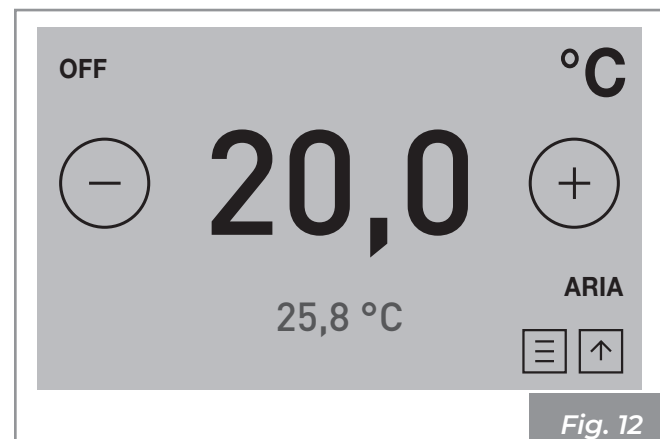

Fig. 12

3 MENU IMPOSTAZIONI

3.1 Impostazioni

Premere sull'icona  per accedere al menu impostazioni.

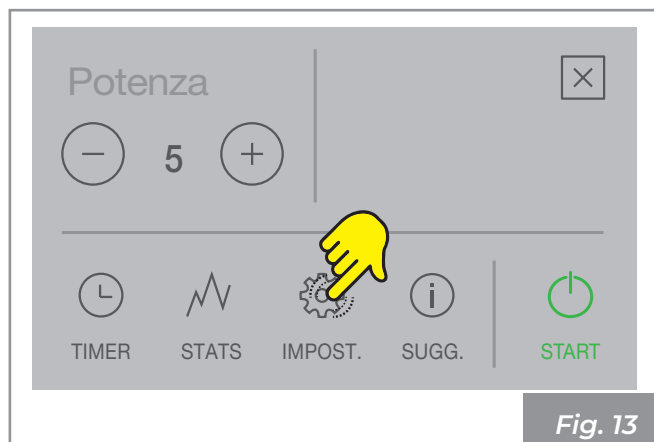







Fig. 13

Premere  e  per scorrere tra l'elenco parametri. Premere sul parametro desiderato per aprire la schermata di modifica del parametro stesso. Generalmente le impostazioni del parametro si modificano premendo sulle icone  o . Premere  per confermare o  per chiudere la schermata di modifica senza salvare.

Lista parametri

Parametro	Descrizione	Valori impostabili	Valori default
Ora	Impostazione ora	Data e Ora impostate correttamente	
Data	Impostazione data		
Combustibile	È possibile impostare 3 diverse configurazioni di combustione	1 ... 3	1
Modalità Eco *	Abilita l'Eco Mode	ON; OFF	<input type="checkbox"/> ON
Antigelo *	Temperatura minima al di sotto della quale l'apparecchio si accende	OFF; 3 ... 20 °C (OFF; 3 ... 50 °C)	OFF
Opzioni display	Imposta il grado di luminosità e le informazioni della schermata in stand-by		
Unità temp.	Unità di misura della temperatura	°C ...°F	°C
Altoparlante	Imposta il livello del volume	OFF; 1 ... 5	2
Ore residue manutenz.	Visualizza le ore mancanti alla manutenzione ordinaria.		2016 h
Menu installatore	Modifica/Visualizza la configurazione dell'apparecchio	PWD: "54"	
Menu di servizio	Menu di competenza del centro di assistenza		
Blocco schermo	Imposta la modalità di blocco dei tasti	OFF; LOW; HI	OFF
Lingua	Imposta la lingua del display:	English Italiano Deutsch Español Français Português Bosanski jezik Slovenscina Swedish Dutch Romana	English
Info	Visualizza le informazioni di sistema		

(*) Parametro disponibile solo in alcune configurazioni

3.1.1 Impostazione "Ora"

Per impostare l'ora:

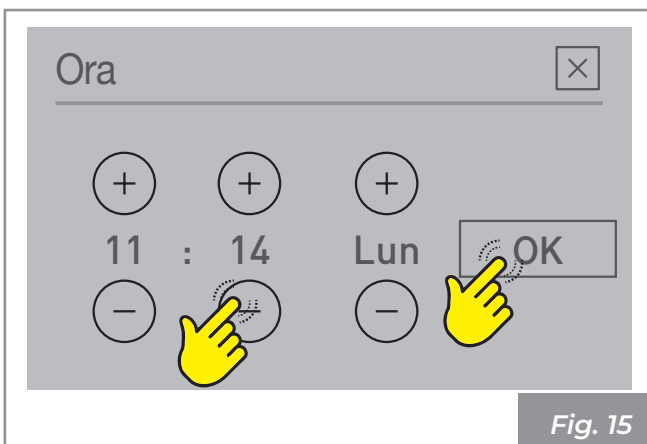
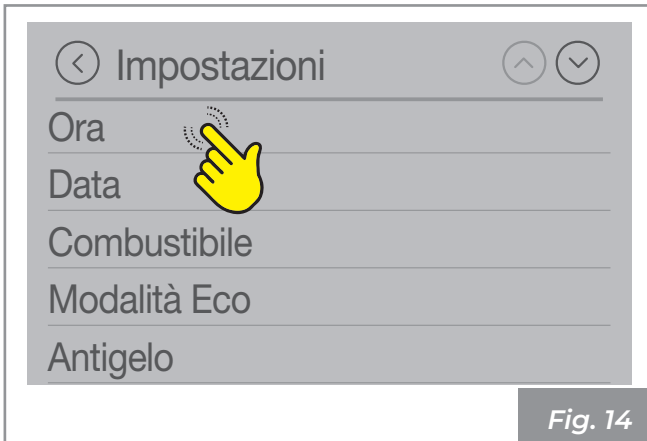

3.1.2 Impostazione "Data"

Per impostare la data:

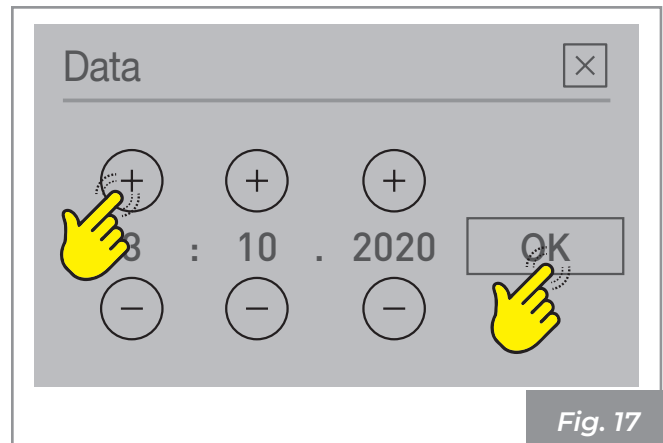
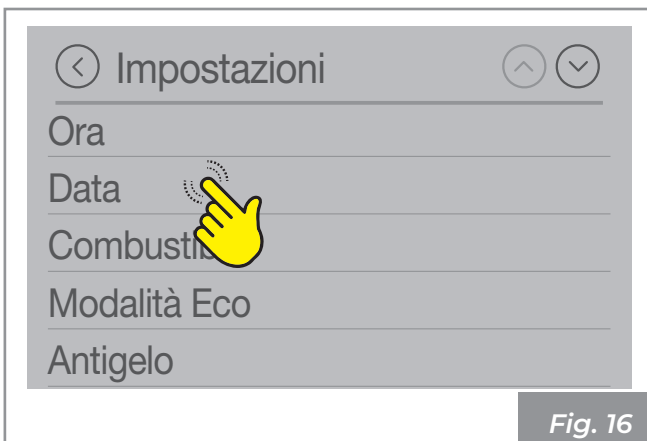

3.1.3 Funzione "Combustibile"

Una combustione ottimale dipende da diversi fattori (tipo di installazione, condizioni di funzionamento e di manutenzione, tipologia di pellet ecc..) In linea di massima, se a fine combustione nel braciere restano molti residui, è consigliabile modificare le configurazioni di combustione (aumentandone il valore) fino a trovare la soluzione più soddisfacente.

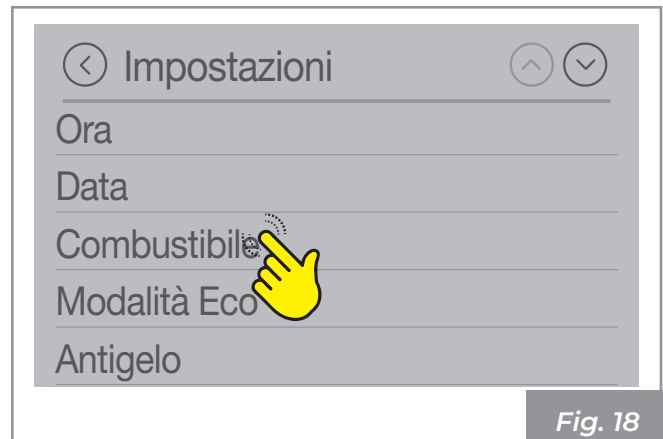

Ottimizzazione della combustione:

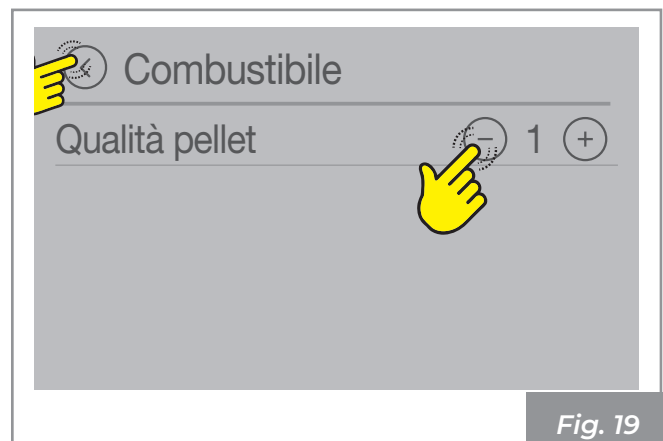

I valori impostabili vanno da 1 a 3.

- 1) Pellet di alta qualità (En Plus)
- 2) Pellet di media qualità
- 3) Pellet di bassa qualità

3.1.4 Funzione "Eco mode"

Funzione disponibile solo nella configurazione 2.

Abilitando questa funzione si fa in modo che l'apparecchio, al raggiungimento della temperatura desiderata in ambiente, si spenga.

Se tale funzione non è abilitata, l'apparecchio modula il proprio funzionamento non spegnendosi.

Per attivare/disattivare tale funzione:

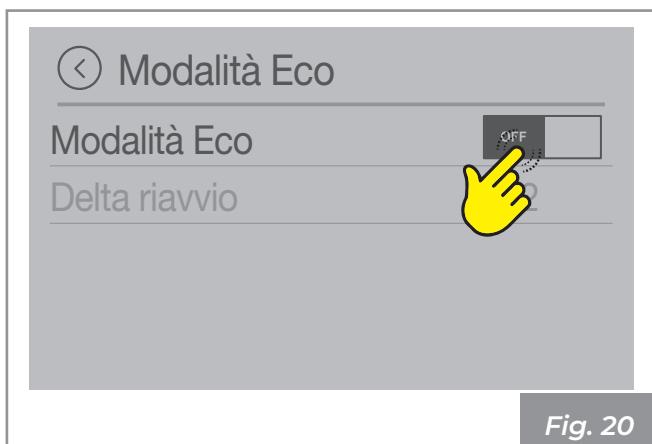

Fig. 20

	Funzione "Eco mode" disattiva
	Funzione "Eco mode" attiva

Quando si attiva la funzione "Eco mode" diventa disponibile la "Delta riavvio" che è il numero di gradi al di sotto della temperatura impostata oltre il quale l'apparecchio si riaccende automaticamente.

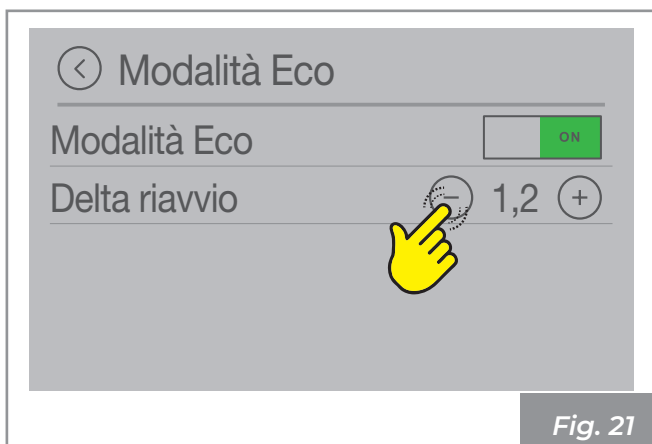

Fig. 21

Esempio: se l'apparecchio è impostato per spegnersi a 20°C (funzione "Eco mode" attiva) e impostiamo un "Delta riavvio" di 4°C, l'apparecchio si riaccenderà quando rileva una temperatura inferiore o uguale a 16°C.

I valori impostabili vanno da 0,5 ... 5,0 °C.

3.1.5 Funzione "Antigelo"

Funzione disponibile solo nelle configurazioni 2, 3 e 4.

È possibile impostare una temperatura minima al di sotto della quale l'apparecchio si accende (al di fuori delle fasce orarie impostate, e solo se il timer è attivo).

Per modificare il valore della temperatura di "antigelo":



Fig. 22



Fig. 23

I valori impostabili:
 (OFF; 3 ... 20°C) per la configurazione 2
 (OFF; 3 ... 50°C) per le configurazioni 3 e 4

3.1.6 Display

Premere "Opzioni display" per modificare le caratteristiche di visualizzazione del display.

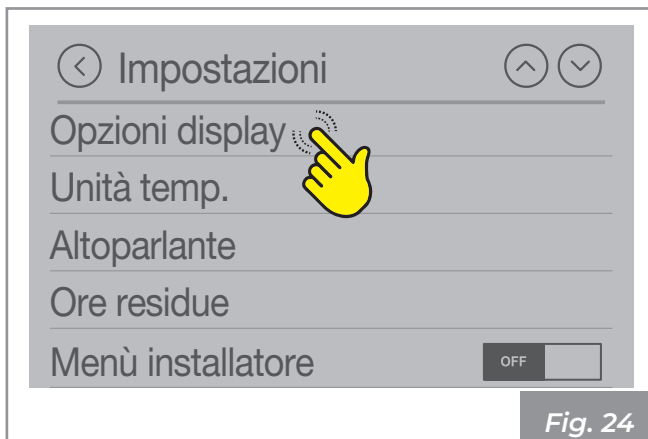

Fig. 24

Grado di luminosità del display

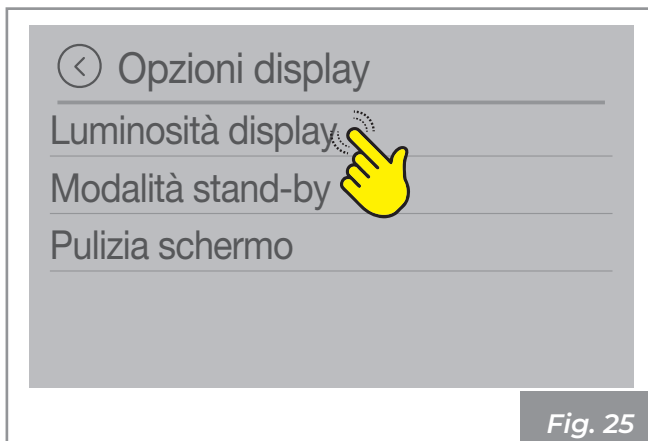

Fig. 25

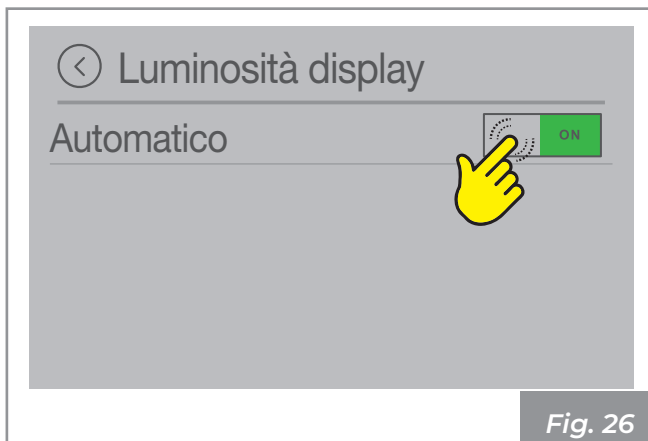

Fig. 26

Automatico: si regola in funzione al sensore della luminosità

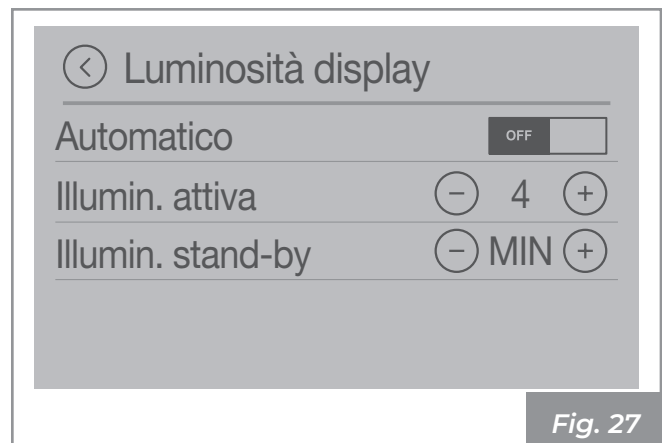

Fig. 27

Luminosità durante l'utilizzo del display: da 0 a 100% di luminosità
I valori impostabili: MIN - 2 - 3 - 4 - MAX;

Luminosità del display quando entra in stand-by: da 0 a 50% di luminosità

- OFF
- MIN - 2 - 3 - 4 - MAX

In posizione OFF, il display diventa nero dopo 60 secondi di non utilizzo, si riattiva toccandolo.

Display in "Modalità stand-by"

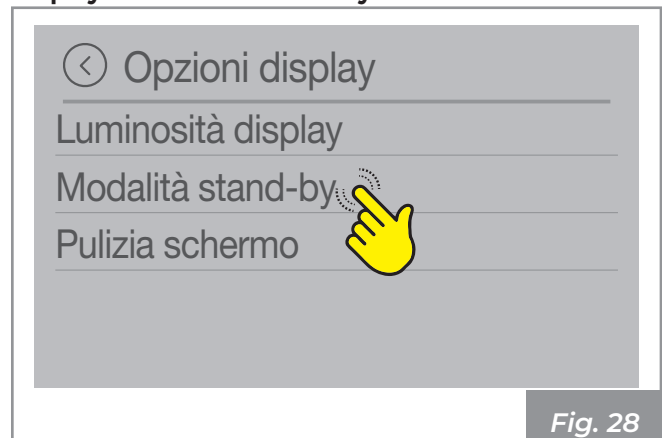

Fig. 28

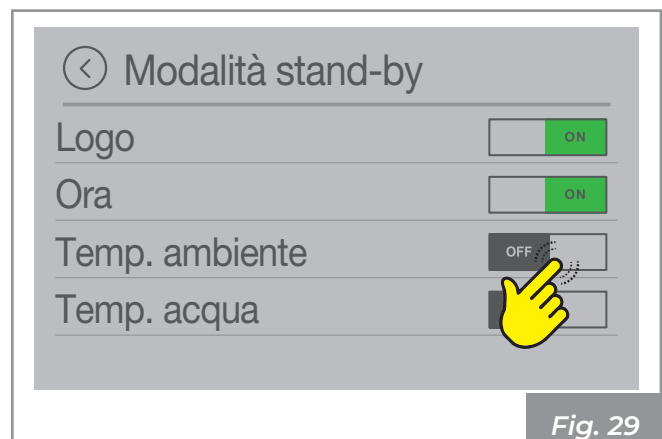

Fig. 29

Si può scegliere cosa visualizzare quando lo schermo è in stand-by:

- Logo
- Ora
- Temperatura ambiente
- Temperatura acqua

Esempio di schermate che si alternano ciclicamente quando lo schermo è in stand-by:

Ora e data

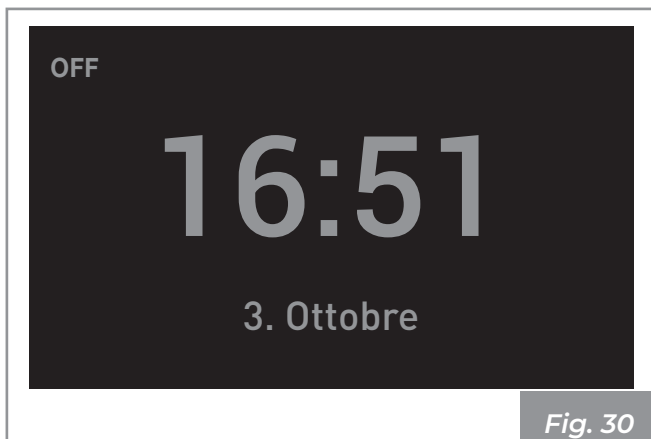

Fig. 30

Temperatura ambiente

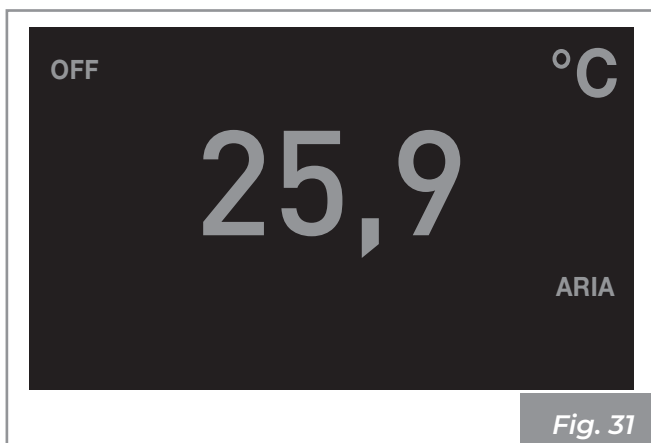

Fig. 31

3.1.7 Funzione "Pulizia"

Impostazione per eseguire la pulizia dello schermo

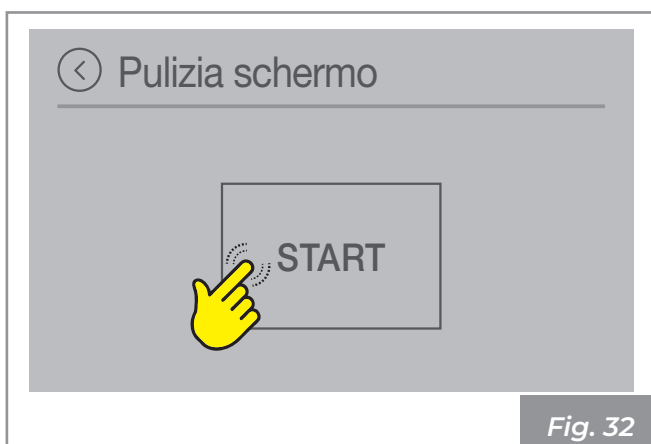

Fig. 32

Premere "START": inizia un conto alla rovescia; il segnale acustico BIP indica che lo schermo è inattivo e si può procedere alla pulizia dello stesso senza interferire nelle sue funzionalità.

Al termine del conto alla rovescia lo schermo touch ritorna ad essere attivo.

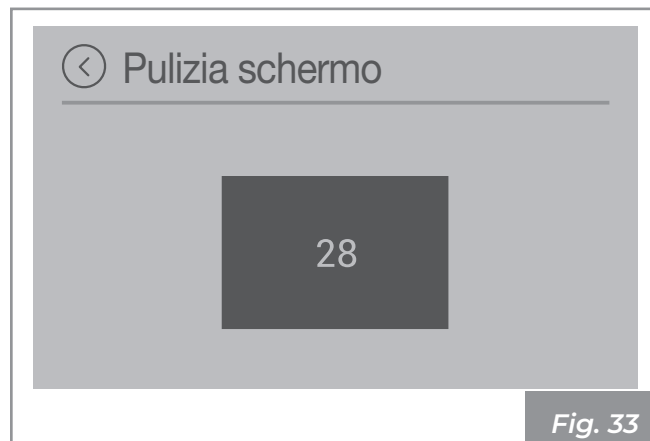

Fig. 33

3.1.8 Impostazione "Unità temperatura"

Per modificare l'unità di misura della temperatura:



Fig. 34

Per cambiare da °C a °F premere su ⊕ o ⊖. Premere per confermare.

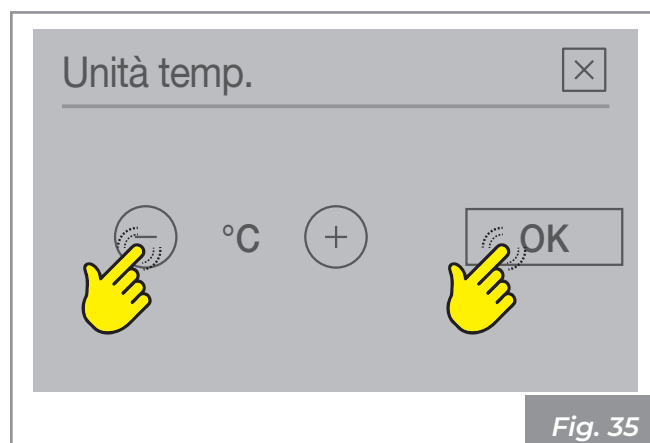

Fig. 35

3.1.9 Impostazione "Altoparlante"

Per modificare il livello di intensità dell'altoparlante:

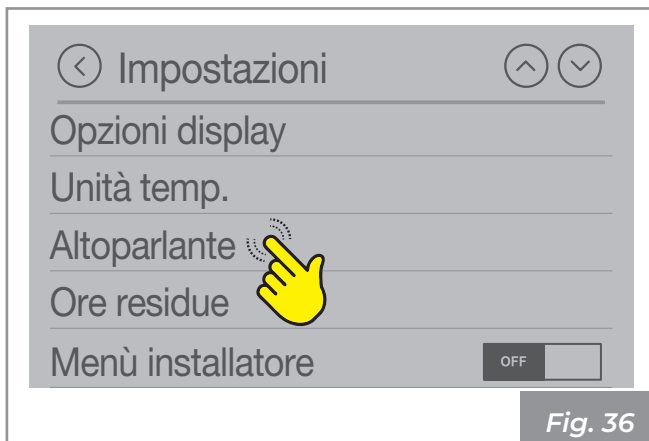

Fig. 36

Premere su ⊕ e ⊖ per impostare il livello di volume desiderato (OFF, 1 ... 5).

Premere per confermare.

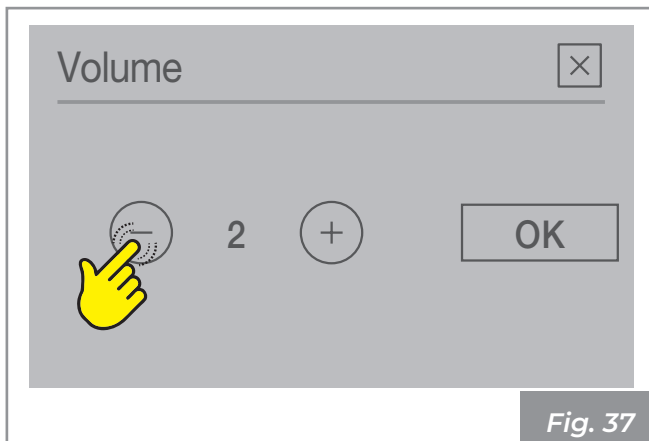

Fig. 37

3.1.10 Funzione "Ore residue manutenzione"

Indica quanto tempo manca alla prossima manutenzione ordinaria.

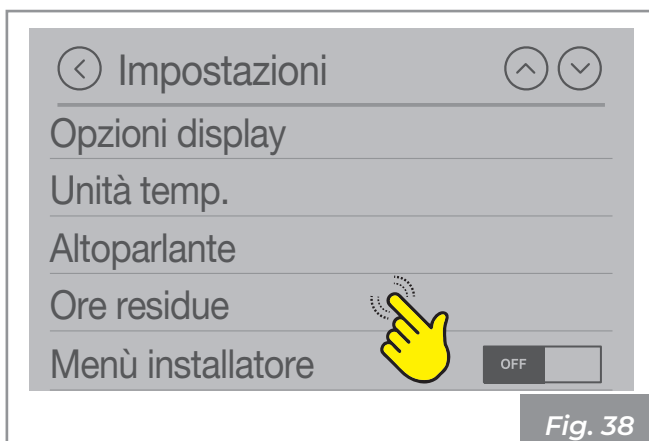

Fig. 38

Visualizza le ore mancanti alla manutenzione ordinaria.

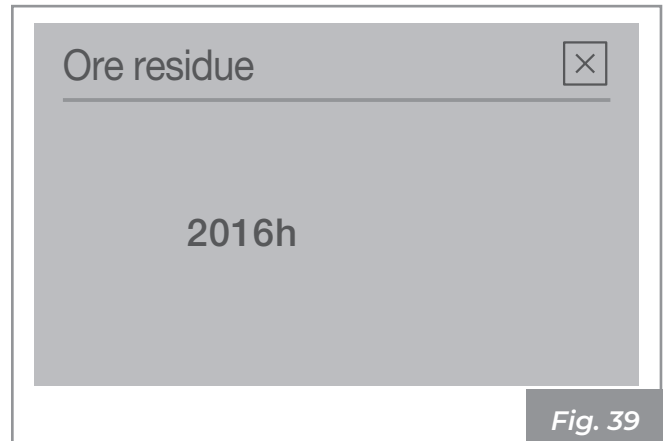

Fig. 39

3.1.11 Menu Installatore



Pericolo: I sottomenu sono protetti da password e sono ad uso esclusivo del centro di assistenza tecnico.

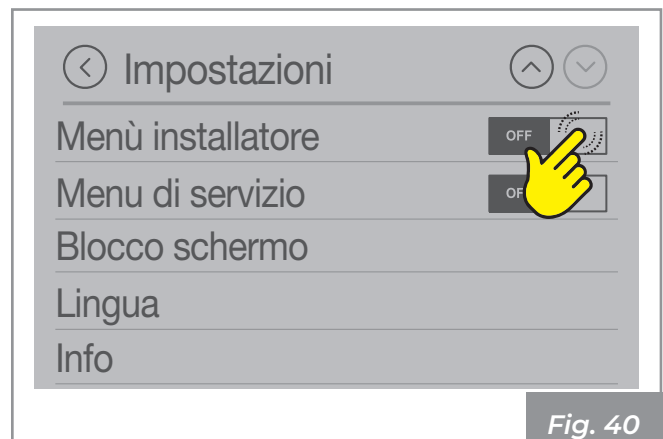

Fig. 40

Premere su **ON**: compare la password, impostare **54** e premere **OK** per confermare.

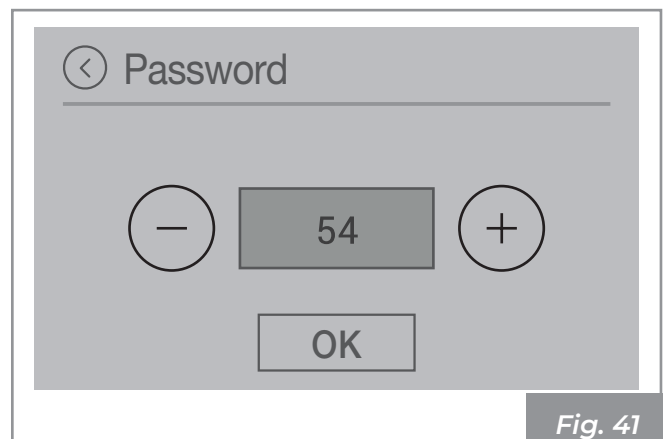

Fig. 41

Premere su "Configurazioni".

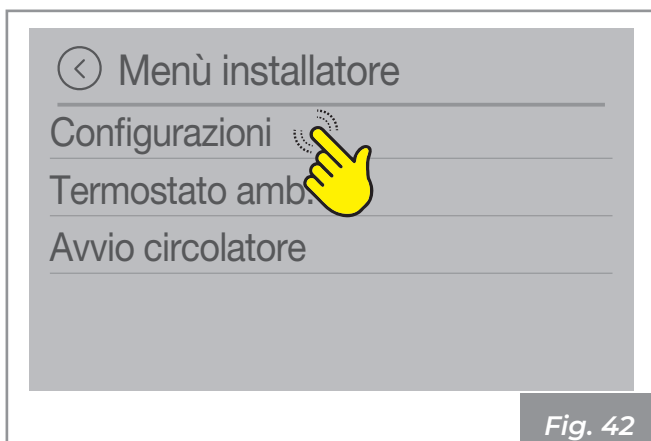

Fig. 42

Si visualizzano le possibili configurazioni dell'apparecchio. La configurazione attualmente impostata risulta in ON, tutte le altre in OFF.

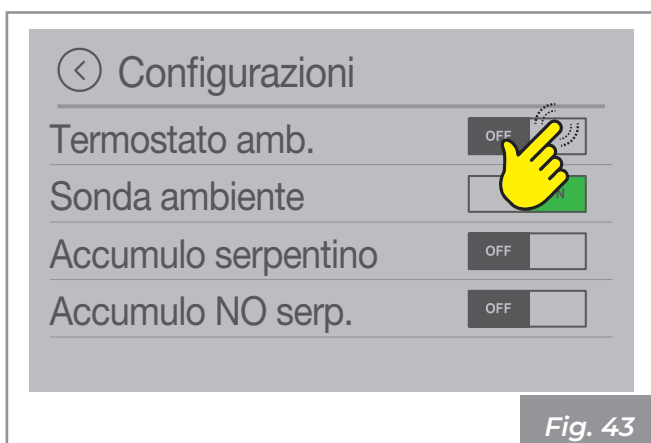

Fig. 43

Configurazione	Descrizione	Default
1	Termostato ambiente	OFF
2	Sonda ambiente	ON
3	Accumulo con serpentino	OFF
4	Accumulo senza serpentino	OFF

Fare riferimento alla configurazione impianto sul manuale di installazione.

3.1.12 Menu di servizio



Pericolo: I sottomenu sono protetti da password e sono ad uso esclusivo del centro di assistenza tecnico.

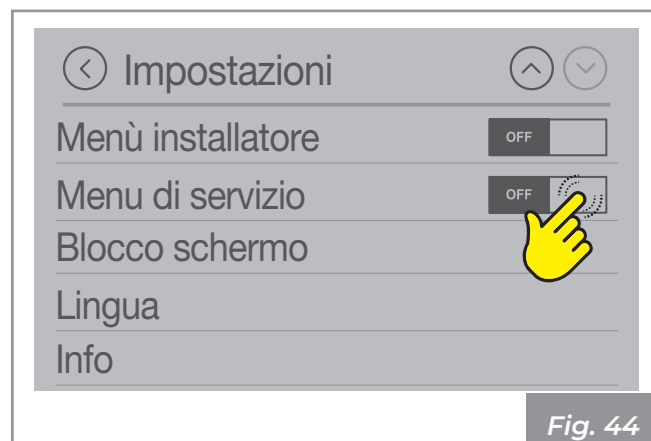

Fig. 44

3.1.13 Funzione "Blocco schermo"

Per bloccare l'accesso alle funzionalità del display:

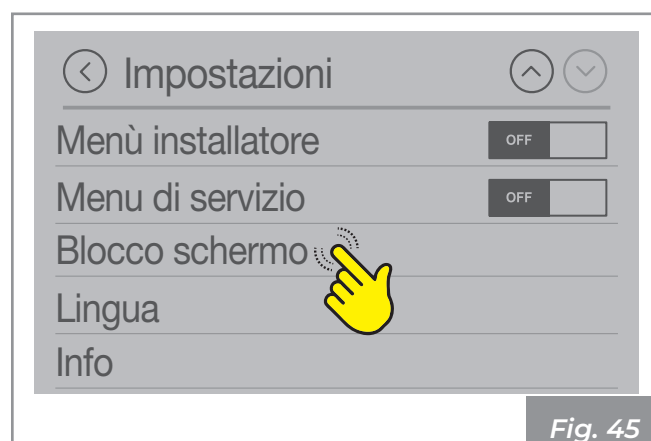

Fig. 45

- **OFF** : Blocco schermo disattivato
- **LOW** : Blocco schermo parziale
- **HI** : Blocco schermo attivato

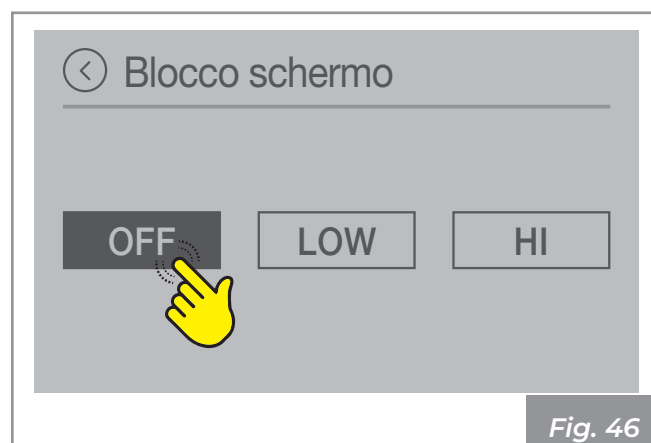
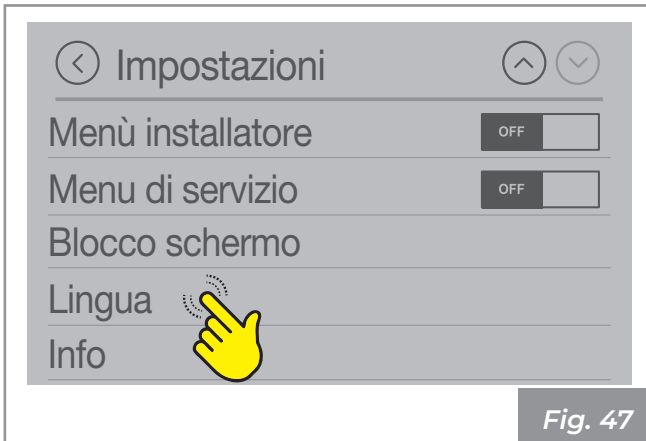

Fig. 46

Per disabilitare la funzione entrare in "Blocco schermo" ed impostare **OFF**.

3.1.14 Lingua

Per impostare la lingua:



3.1.15 Informazioni

Per visualizzare le informazioni di sistema:

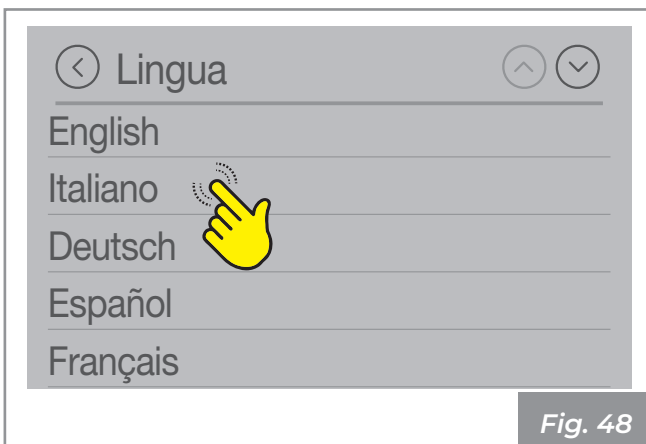
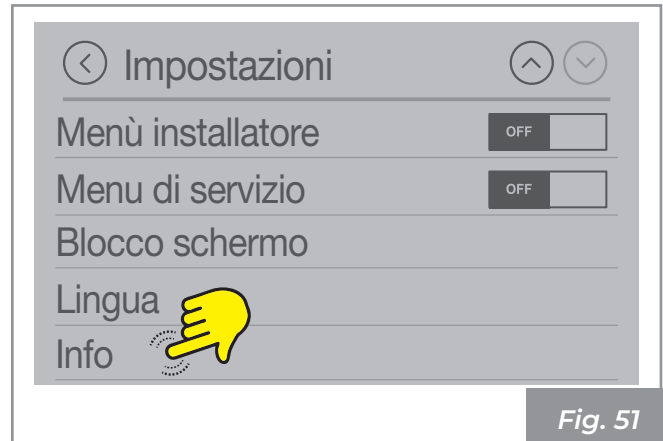

Visualizza la versione software corrente.

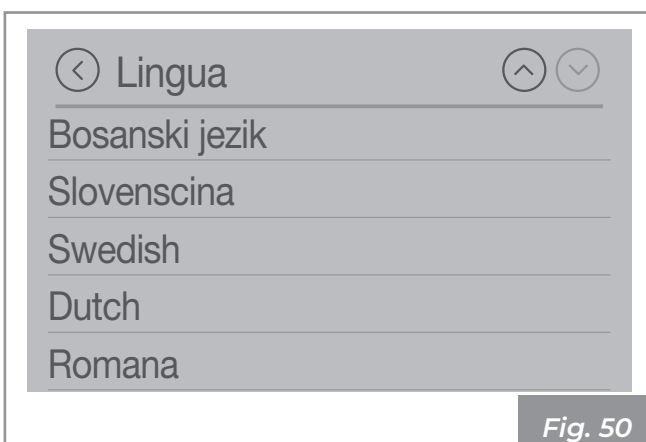
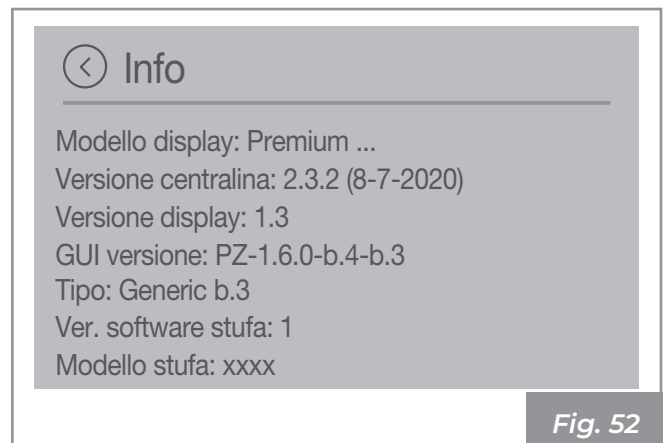

4 USO

4.1 Accensione



Pericolo: Prima di ogni accensione, accertarsi che il braciere sia completamente vuoto e correttamente posizionato nella sua sede.

Sono due le modalità per avviare l'apparecchio.

Prima modalità:

Premere l'icona 

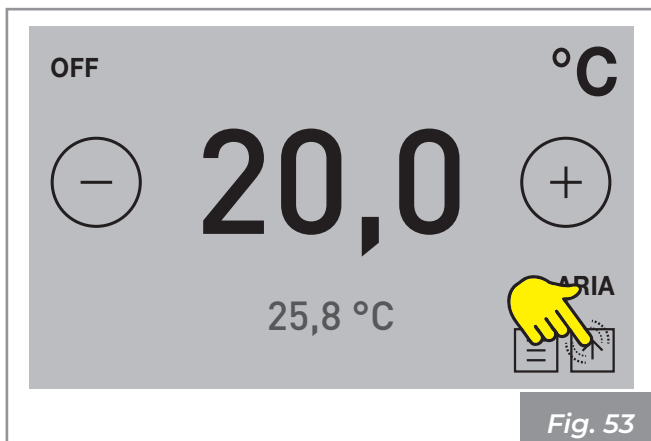

Fig. 53

Mantenere premuto per due secondi l'icona per avviare il prodotto.



Fig. 54

Seconda modalità:

Accedere al menu principale e tenere premuto START per qualche secondo.

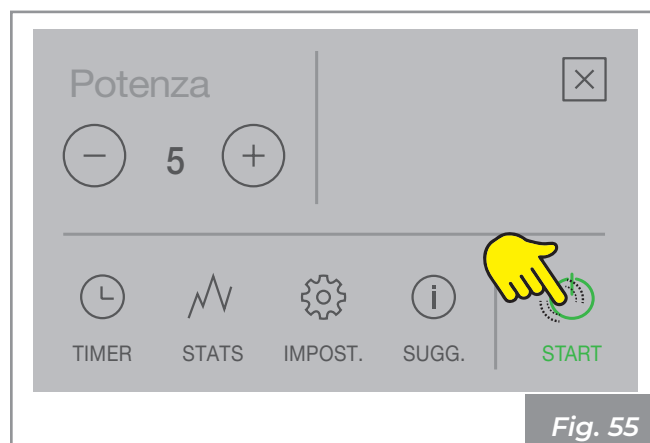

Fig. 55

A questo punto l'apparecchio inizia la fase di accensione.

Si visualizza questa sequenza:

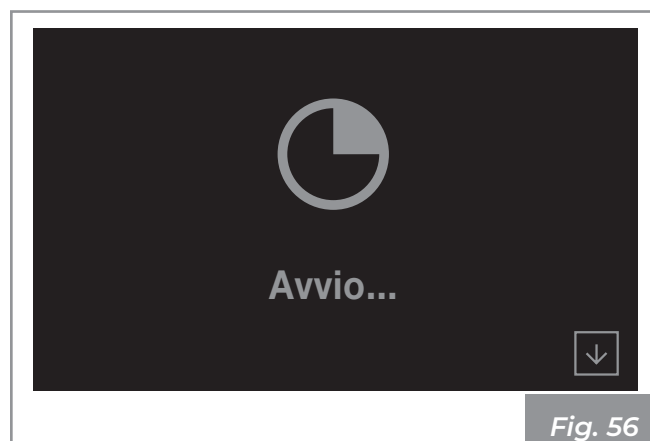

Fig. 56

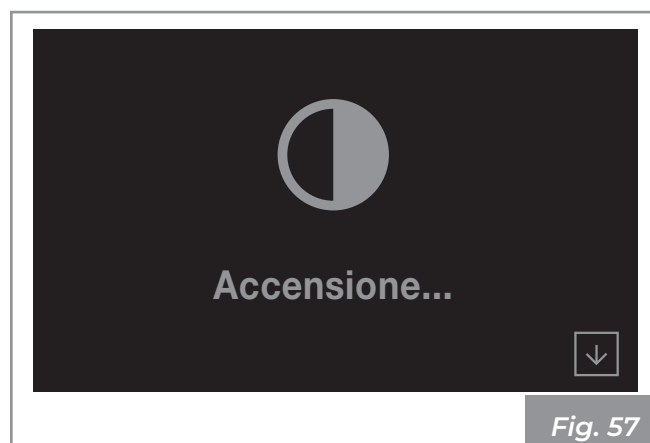

Fig. 57

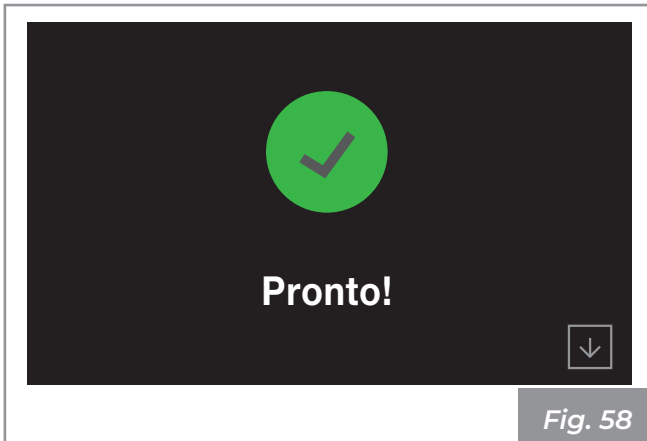

Fig. 58

Dopo alcuni secondi appare la schermata iniziale:

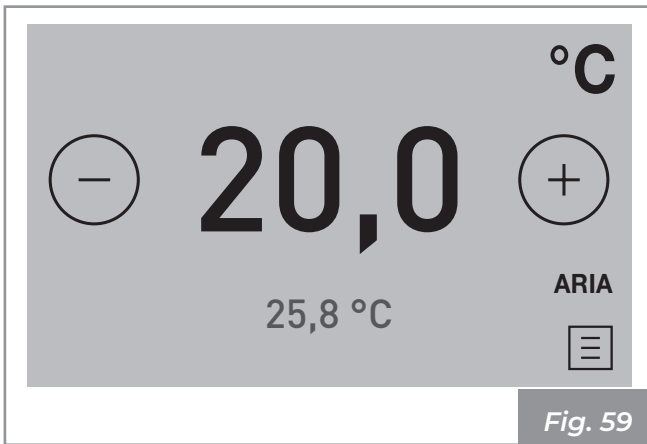

Fig. 59



Attenzione: Accensione automatica: l'apparecchio è dotato di un dispositivo automatico che consente l'accensione del pellet senza l'utilizzo di altri accenditori tradizionali.



Pericolo: Evitare di accendere manualmente l'apparecchio se il sistema di accensione automatico è compromesso.



Attenzione: Durante la prima accensione dell'apparecchio si possono generare sgradevoli odori o fumi causati dall'evaporazione o dall'essiccamento di alcuni materiali utilizzati. Tale fenomeno andrà via via a scomparire.

Si consiglia, durante le prime accensioni, di mantenere i locali ben arieggiati.

Apparecchi della serie "Ermetica":

Ogni qual volta si apre la porta del focolare evitare di lasciarla aperta per un lungo periodo onde evitare che il sensore di chiusura notifichi lo stato di porta aperta, attraverso un allarme acustico.

4.1.1 Modifica della temperatura ambiente

Modificando tale valore si definisce la temperatura che si desidera raggiungere in ambiente, letta direttamente da una sonda posta sull'apparecchio.

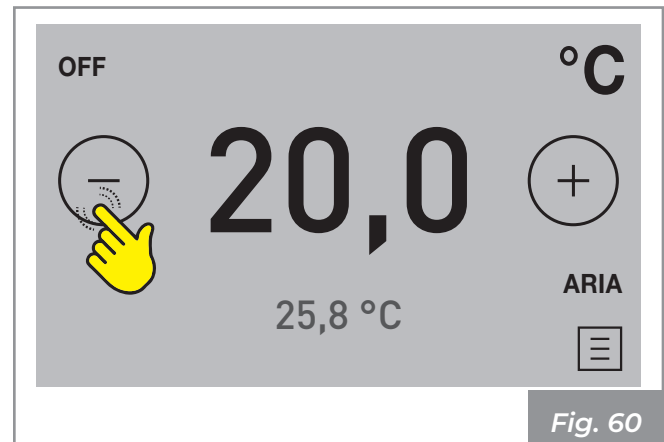

Fig. 60

Per modificare il valore della temperatura premere sulle icone \oplus o \ominus :

I valori impostabili vanno da 10°C a 40°C.

4.1.2 Modifica della potenza

La potenza definisce la quantità di calore prodotta dall'apparecchio e quindi incide direttamente anche sui consumi.

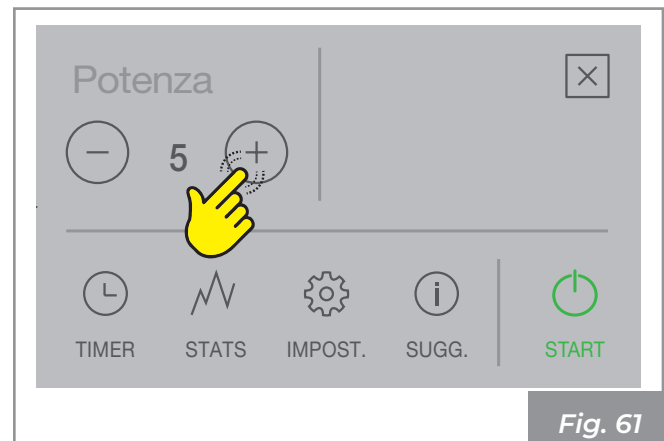

Fig. 61

Per modificare il valore della potenza premere sulle icone \oplus o \ominus :

I valori impostabili vanno da 1 (minimo) a 5 (massimo).

4.2 Modifica dei parametri

È possibile modificare i parametri di funzionamento secondo quanto riportato al capitolo "3 Menu impostazioni"



Indicazione: I valori impostati verranno mantenuti fino alla successiva variazione, anche ad apparecchio spento o scollegato dall'alimentazione elettrica.

4.3 Spegnimento

Per spegnere l'apparecchio tenere premuto il tasto STOP per qualche secondo;

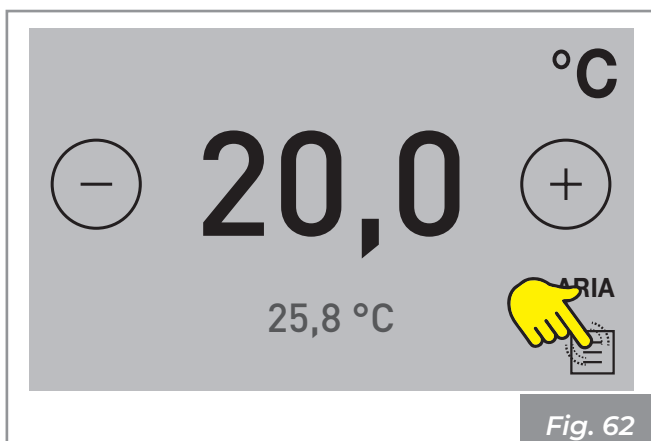

Fig. 62

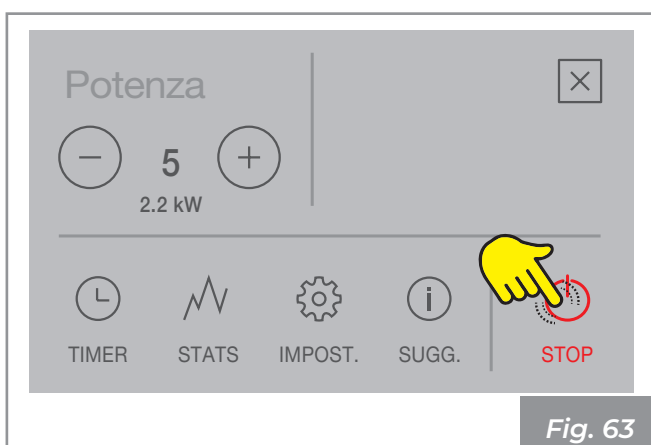

Fig. 63

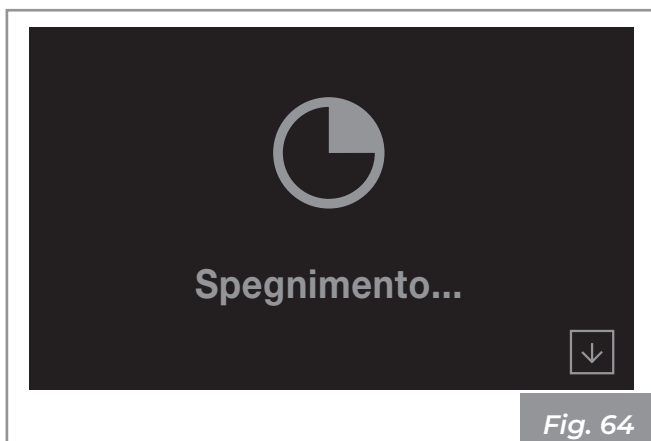

Fig. 64

Se la temperatura risulta ancora elevata, viene avviata una fase di raffreddamento:

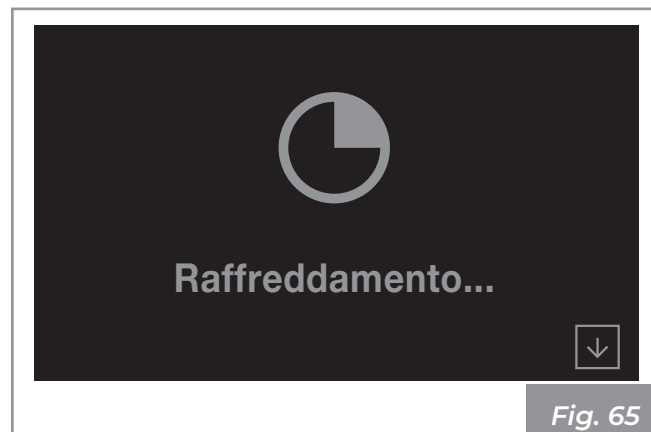

Fig. 65



Indicazione: Per effettuare una nuova accensione si consiglia di attendere che l'apparecchio si sia completamente raffreddato.



Pericolo: Si raccomanda di spegnere l'apparecchio seguendo scrupolosamente quanto sopra riportato. È vietato spegnere l'apparecchio togliendo l'alimentazione elettrica.

4.4 Riaccensione dopo il black-out

In caso di interruzione di corrente elettrica, l'apparecchio si riaccenderà automaticamente, verificando le condizioni di sicurezza, al ritorno dell'alimentazione.

4.5 Funzionamento con termostato ambiente

Quando l'apparecchio viene comandato da un termostato (o cronotermostato) esterno, l'installatore deve aver impostato la **configurazione 1**.

In questo caso l'apparecchio si spegne quando il termostato esterno è soddisfatto (circuito aperto). L'apparecchio si riaccende automaticamente quando la temperatura scende al di sotto del valore impostato sul termostato esterno (circuito chiuso).



Indicazione: Alla prima accensione, o qualora lo spegnimento sia avvenuto direttamente dall'apparecchio, si dovrà procedere ad accendere l'apparecchio direttamente dal pannello comandi.

4.6 Funzionamento con sonda ambiente a bordo stufa

L'apparecchio può essere acceso/spento manualmente o in modo programmato.

L'apparecchio modula la potenza in funzione della temperatura ambiente letta dalla sonda a bordo (tenta di mantenere la temperatura desiderata consumando il meno possibile).

Nell'eventualità l'utente abbia abilitato la funzione "Eco-mode", l'apparecchio invece di modulare si spegne al raggiungimento della temperatura impostata e si riaccende quando la temperatura ambiente scende al di sotto del delta impostato (vedi paragrafo "3.1.4 Funzione "Eco mode"").



Fig. 66

5 FUNZIONI DISPONIBILI

5.1 Impostazione timer

È possibile impostare, abilitare ed assegnare ai vari giorni della settimana, i programmi personalizzati per l'accensione e/o lo spegnimento automatico dell'apparecchio.

È possibile configurare fino a sei programmi personalizzati.

Per ciascun programma si può impostare: ora di accensione, ora di spegnimento e temperatura desiderata.

A ciascun giorno della settimana è possibile assegnare fino a tre programmi.

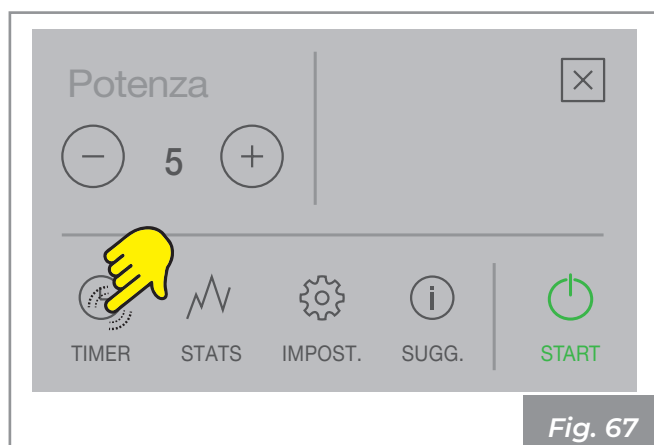

Fig. 67

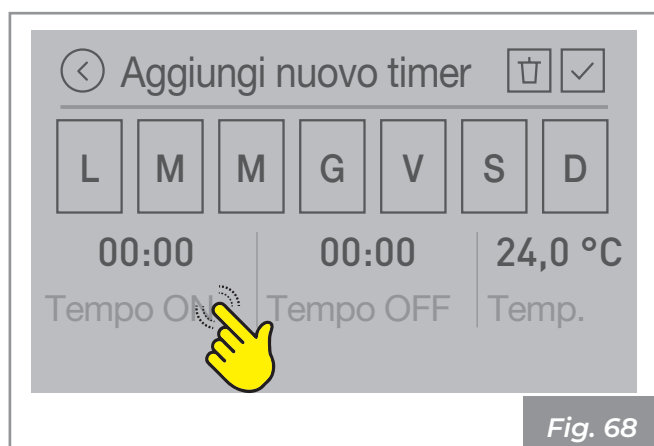

Fig. 68

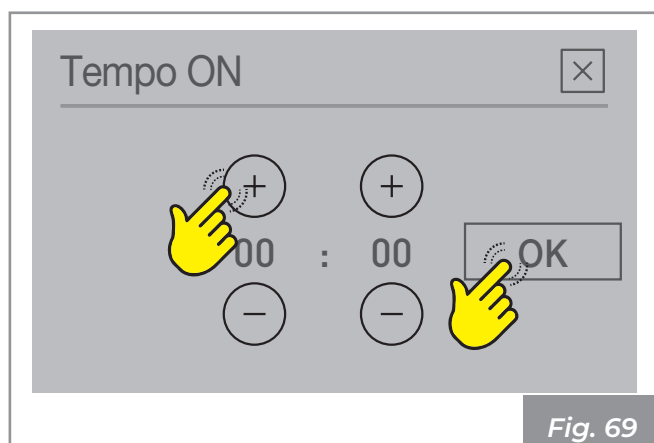

Fig. 69

Esempio di Timer impostato

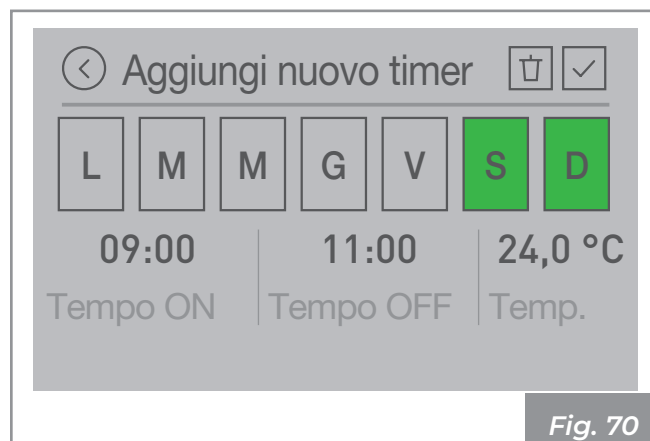

Fig. 70



Indicazione: La temperatura impostabile sul timer è in funzione al tipo di configurazione dell'impianto. Per maggiori dettagli vedi paragrafo "1.4 Schermata iniziale e set temperatura".

5.1.1 Abilitazione/disabilitazione timer

Selezionare ON per abilitare il timer oppure OFF per disabilitarlo.

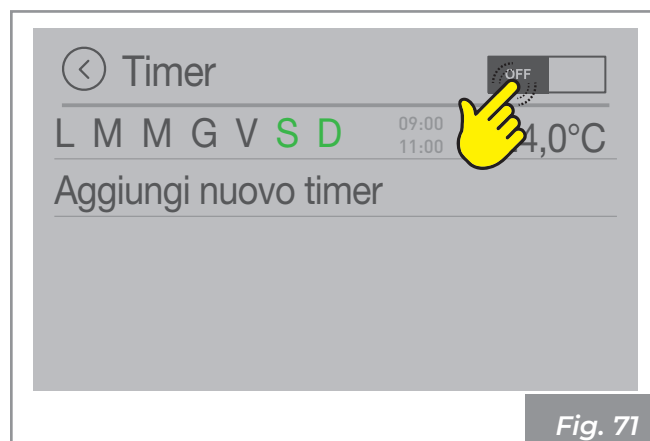

Fig. 71

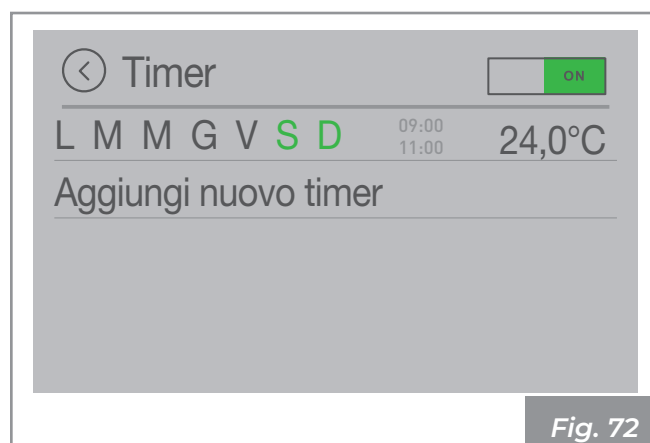

Fig. 72

L'apparecchio si accenderà alle 9:00 e si spegnerà alle 11:00 il sabato e la domenica

5.2 Statistiche

È possibile visualizzare le statistiche di utilizzo dell'apparecchio.

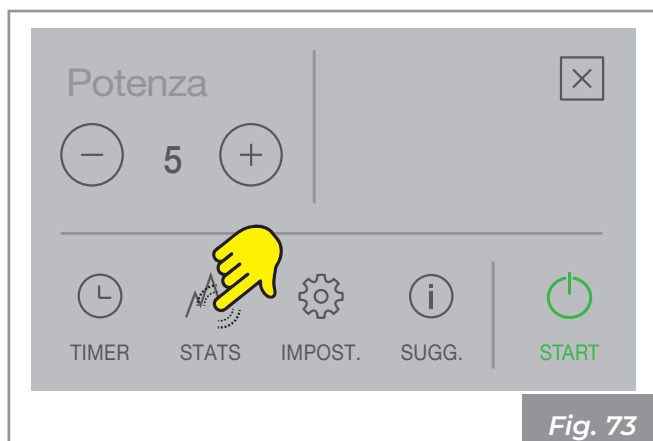

Fig. 73

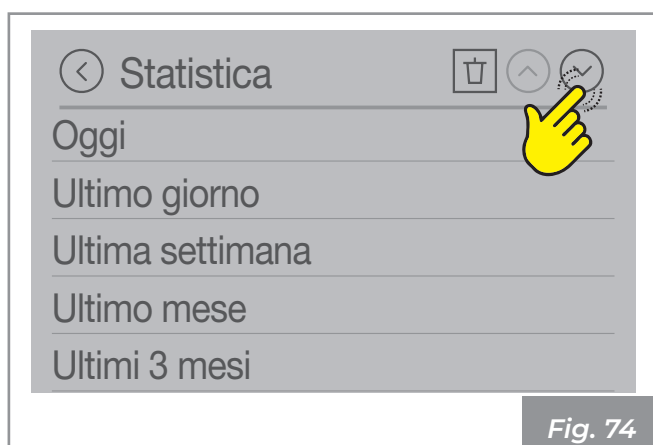

Fig. 74

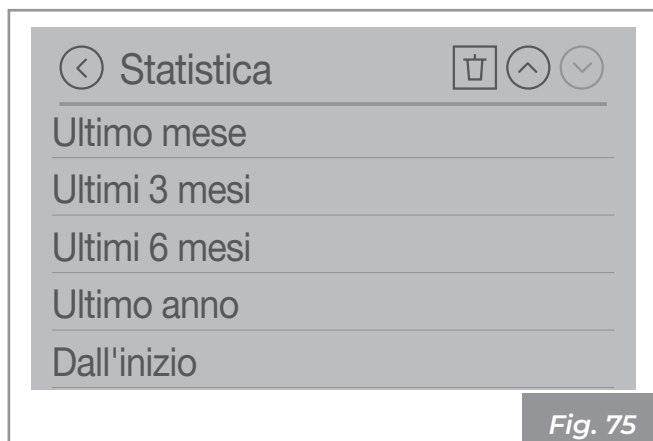

Fig. 75

Esempio di statistica

Selezionando "Oggi" posso visualizzare:

- i chilogrammi di pellet utilizzati
- il tempo di accensione
- la potenza media prodotta
- la temperatura ambiente media

Oggi	
Consumo totale	0 kg
Tempo riscald.	0:00
Potenza media	0.0 kW
Temp. media	25,7 °C

Fig. 76

Cancella statistiche

Premere l'icona  per cancellare le statistiche:

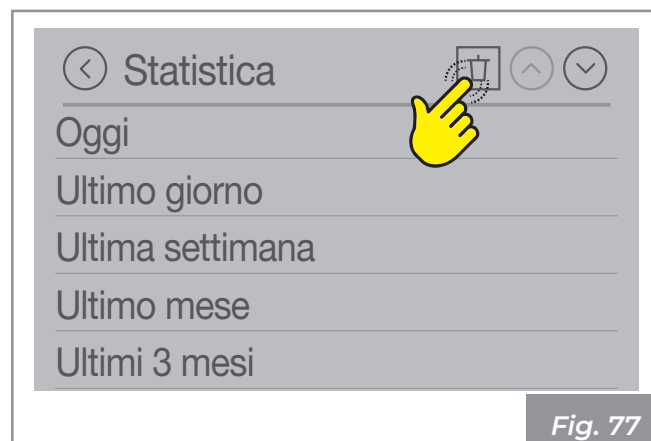

Fig. 77

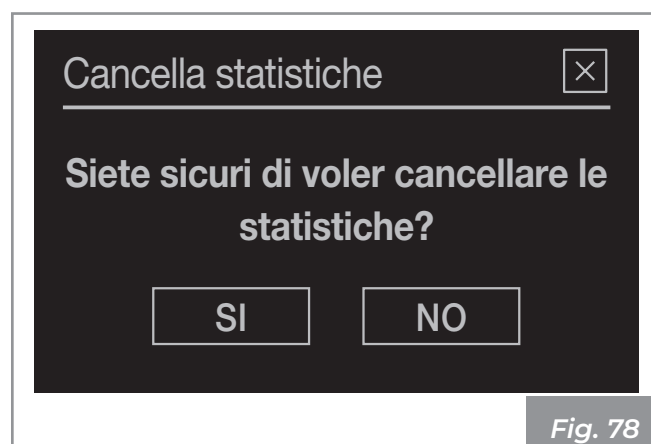

Fig. 78

5.3 Suggerimenti di funzionamento

Questo menù viene utilizzato per fornire semplici consigli sul buon funzionamento del prodotto.

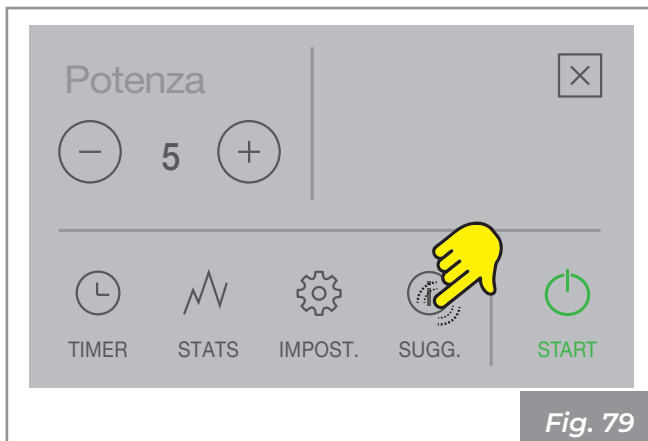

Fig. 79

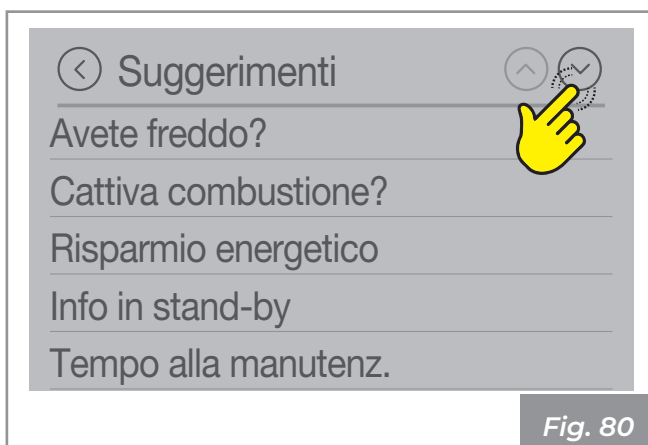

Fig. 80

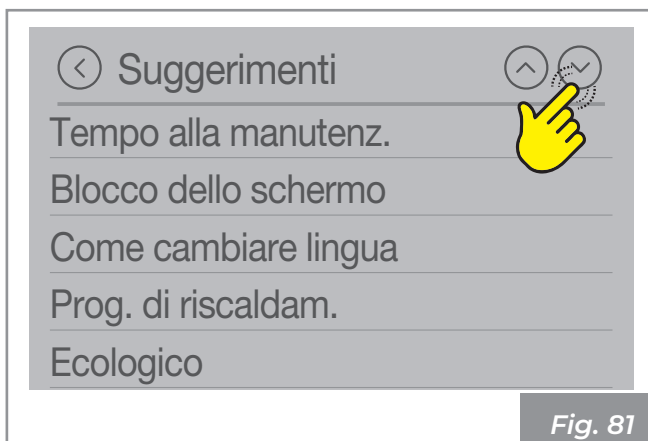

Fig. 81

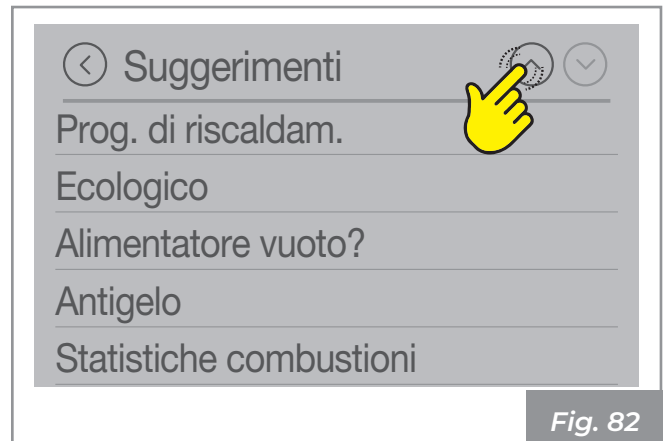

Fig. 82

6 ANOMALIE E POSSIBILI RIMEDI

Quando si verifica un'anomalia di funzionamento viene attivato un allarme acustico (beep) e nel display appare la possibile causa con un codice numerico di errore.

Gli errori sono suddivisi in:

- **Allarmi** **E**: errori bloccanti. L'apparecchio si spegne. La causa del messaggio di allarme deve essere risolta prima di riaccendere l'apparecchio.
- **Avvisi** **!**: semplici avvertimenti che non bloccano il funzionamento dell'apparecchio (in alcuni casi lo limitano). Si resettano automaticamente una volta rimossa o cessata la causa che li ha generati.

Esempio di visualizzazione Allarme E102:

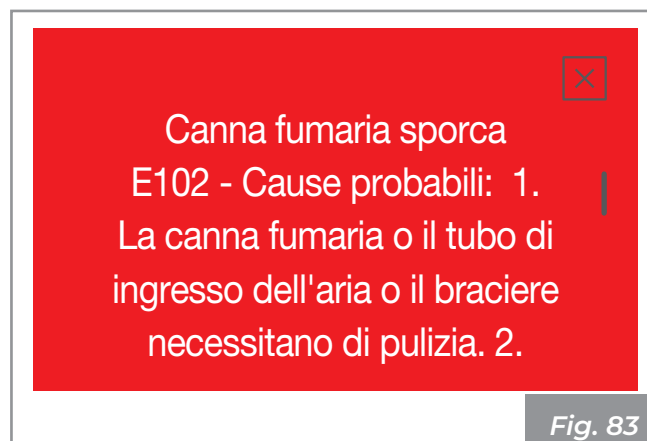

Fig. 83

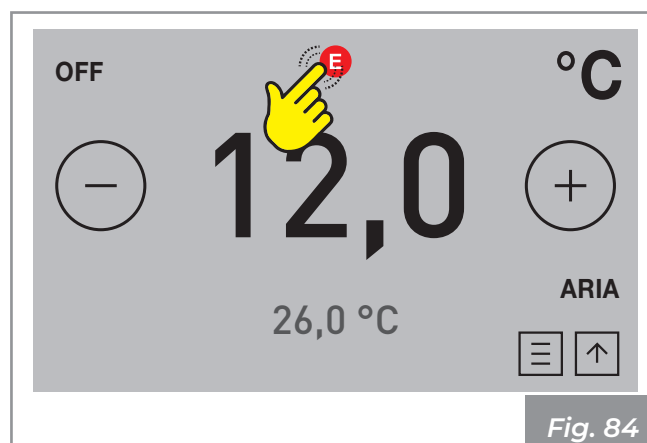

Fig. 84

6.1 Descrizione allarmi

Codice allarme	Descrizione	Possibili cause
E002	IR errore di comunicazione	Sensore infrarossi non funzionante. Chiamare il servizio di assistenza..
E004	MB errore di comunicazione	Errore di comunicazione MB
E101	Errore fuoco	Accensione fallita
E102	Canna fumaria sporca	1. La canna fumaria o il tubo di ingresso dell'aria o il braciere necessitano di pulizia. 2. Dispositivo spento manualmente prima della rilevazione di fiamma.
E104	Scuotibraciere bloccato	Svuota e pulisci il braciere. Resetta l'errore.
E105	Errore NTC2	Sensore collegato a T02 malfunzionante o disconnesso. Chiamare il servizio di assistenza.
E106	Errore NTC3	Sensore collegato a T05 malfunzionante o disconnesso. Chiamare il servizio di assistenza.
E108	Errore interruttore di sicurezza	Interruttore collegato a I01 aperto. Reimpostare l'allarme e riavviare il dispositivo. Se l'errore persiste, chiamare il servizio di assistenza.
E109	Errore di pressione	Sensore di pressione o sicurezza termica aperto. Reimpostare l'allarme e riavviare il dispositivo. Se l'errore persiste, chiamare il servizio di assistenza.

Codice allarme	Descrizione	Possibili cause
E110	NTC1	Sensore collegato a T01 malfunzionante o disconnesso. Chiamare il servizio di assistenza.
E111	TC1	Sensore collegato a T03 malfunzionante o disconnesso. Chiamare il servizio di assistenza.
E113	Sovra temperatura gas	Sovra temperatura Fumi. Pulire scambiatore o canna fumaria.
E114	Mancata accensione	Tempo per l'accensione scaduto (svuotare il braciere e riavviare il dispositivo) o serbatoio vuoto (riempire il serbatoio).
E115	Errore generale	Contattare il servizio di assistenza.

6.2 Reset allarmi

In caso di allarme il display diventa rosso e viene emesso un segnale acustico (beep).

Viene visualizzato il codice di allarme e la possibile causa.

L'apparecchio si spegne.

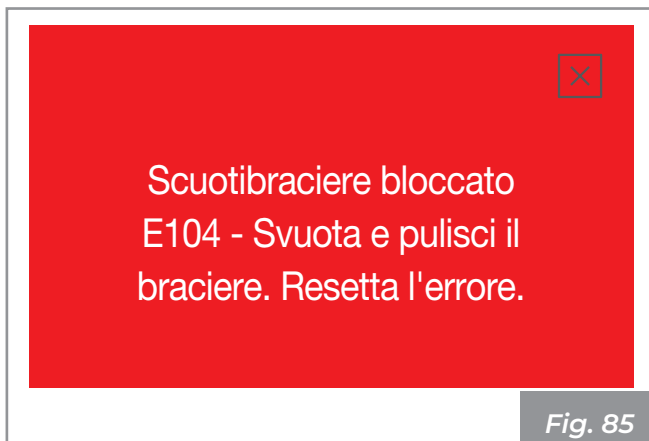

Pericolo: In caso di allarme "E108" o "E109", prima di resettare l'allarme, riattivare il termostato a riarmo manuale posto sul retro dell'apparecchio (a cura del Centro di Assistenza Tecnico).

A questo punto è possibile procedere con una nuova accensione.

Se si chiude la schermata premendo su  l'allarme non si resetta e rimane l'icona .

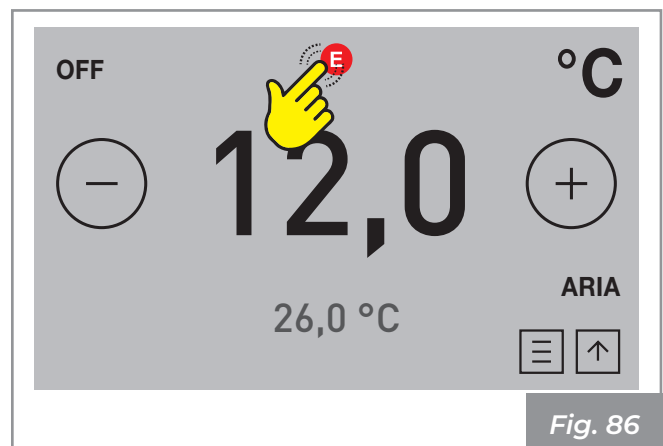

Per vedere ancora la descrizione dell'allarme premere sull'icona .

Prima di procedere con una nuova accensione verificare che:

- l'apparecchio si sia raffreddato;
- la causa del messaggio di allarme sia risolta;
- il braciere sia pulito e sgombro da qualsiasi residuo di cenere o pellet;
- il braciere sia correttamente posizionato nella sua sede;
- le porte del focolare e del serbatoio siano perfettamente chiuse.

6.3 Descrizione avvisi

Codice avviso	Descrizione	Possibili cause - rimedi
A001	Livello combustibile basso	Avviso di basso livello di combustibile, rifornire il serbatoio.
A002	Manutenzione	Tempo di funzionamento esaurito, contattare il servizio assistenza per la manutenzione.
A004	Batteria scarica	Batteria scarica, contattare il servizio assistenza per la sostituzione.
A005	Sensore velocità	Guasto al sensore di velocità, contattare il servizio assistenza.
A007	Sensore pressione/fluxo aria	Modalità operativa alternativa, funzione limitata. Sensore flusso aria malfunzionante, contattare il servizio assistenza.

6.4 Reset avvisi



In caso di avviso il display diventa giallo e viene emesso un segnale acustico (beep). Viene visualizzato il codice di avviso e la possibile causa.

Per vedere ancora la descrizione dell'avviso premere sull'icona .

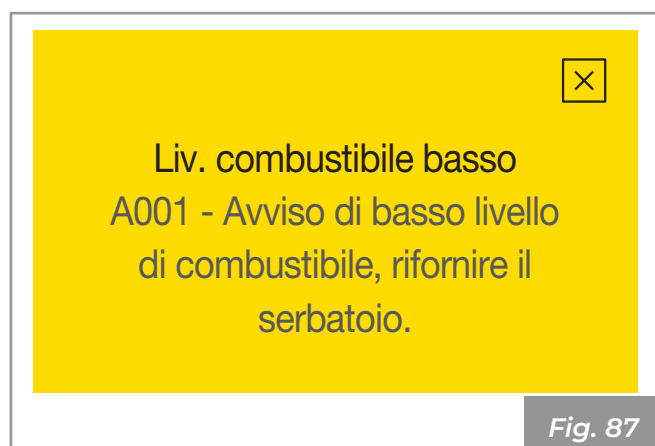
Per resettare l'avviso il problema deve essere risolto.



Attenzione: In caso di avviso l'apparecchio è ancora operativo (in alcuni casi ha funzioni limitate).

Se si chiude la schermata premendo su  l'avviso non si resetta e rimane l'icona .

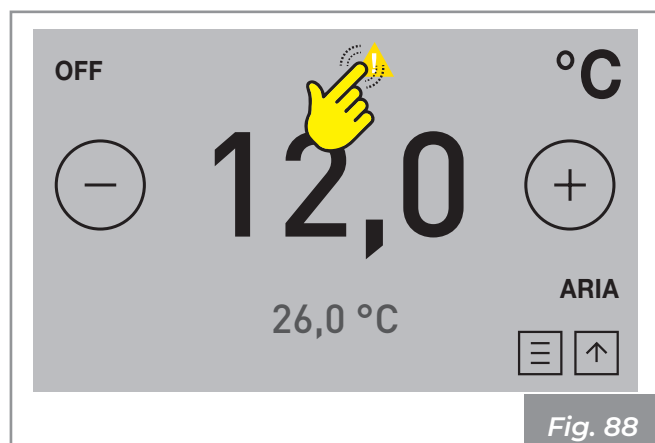

CONTENTS

1 CONTROL PANEL	30
1.1 Description	30
1.2 General description of icons	30
1.3 Navigation tree	31
1.4 Start screen and set temperature	32
2 PRELIMINARY OPERATIONS	34
2.1 Pellet loading	34
2.2 Electrical power supply	34
3 SETTINGS MENU	35
3.1 Settings	35
3.1.1 "Time" setting	36
3.1.2 "Date" setting	36
3.1.3 "Fuel" function	36
3.1.4 "Eco mode" function	37
3.1.5 "Antifreeze" function	37
3.1.6 Display	38
3.1.7 "Cleaning" function	39
3.1.8 "Temperature unit" setting	39
3.1.9 "Speaker" setting	40
3.1.10 "Time to service" function	40
3.1.11 Installer Menu	40
3.1.12 Service menu	41
3.1.13 "Screen lock" function	41
3.1.14 Language	42
3.1.15 Information	42

4 USE	43
4.1 Ignition	43
4.1.1 Modifying the room temperature	44
4.1.2 Modifying the power	44
4.2 Modifying the parameters	44
4.3 Shutdown	45
4.4 Restart after a power failure	45
4.5 Operation with external thermostat	46
4.6 Operation with room sensor on stove	46
5 AVAILABLE FUNCTIONS	47
5.1 Timer setting	47
5.1.1 Timer enabling/disabling	47
5.2 Statistics	48
5.3 Operating tips	49
6 TROUBLESHOOTING	50
6.1 Description of alarms	50
6.2 Reset alarms	51
6.3 Description of warnings	52
6.4 Reset warnings	52

SYMBOLS USED IN MANUAL AND THEIR MEANING



Indication: To highlight important information.



Attention: To highlight particularly important and delicate operations.



Hazard: To highlight actions, which, if not correctly carried out, may cause general injuries and generate malfunctions or material damage to the device.

1 CONTROL PANEL

1.1 Description

The control panel consists of:

- 1) IR receiver (infrared)
- 2) Room light sensor
- 3) Touch Screen
- 4) Speakers
- 5) RJ11 connector

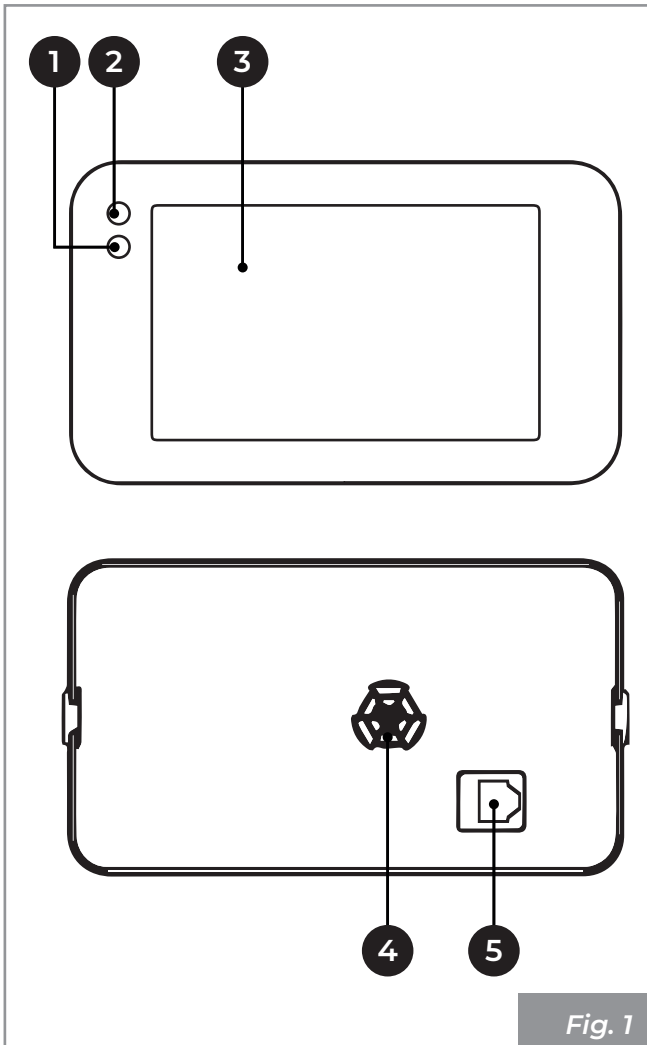

Fig. 1



Indication: The screen is the Touch Screen type and therefore simply needs to be tapped in order to activate it, without pressing any buttons.

1.2 General description of icons

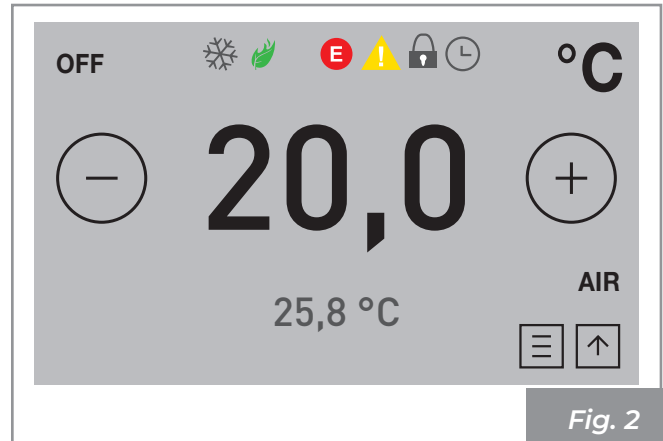

Fig. 2

Icon	Description
	Alarm
	Warning
	Eco mode function active
	Main menu
	Device on/off
	Timer activated
	"Antifreeze" function active
	Screen lock
OFF	Indication that device is off
20.0	Set temperature
25.8	Temperature detected by sensor

1.3 Navigation tree

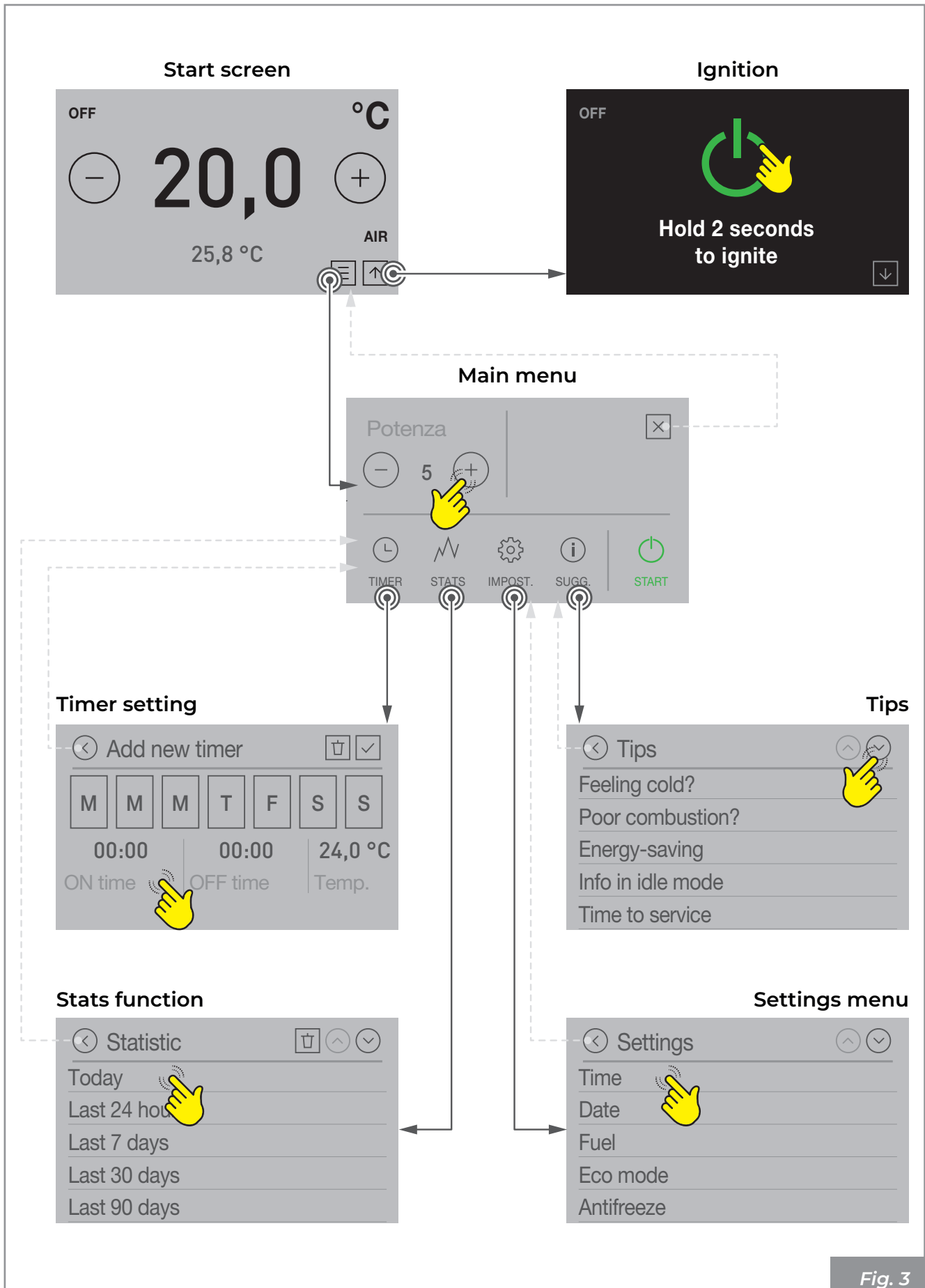

Fig. 3

1.4 Start screen and set temperature

Different start screens and temperatures will be displayed depending on the installation configuration of the device.

Configuration 1 - External thermostat

Start screen

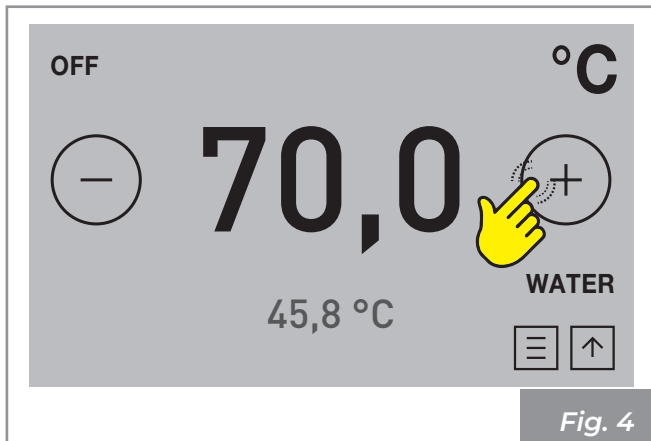

This screen displays the delivery temperature of the boiler hot water.

Press icons \oplus or \ominus to change the desired delivery temperature (large digits)
The value can be set between 45°C and 80°C.

The small digits display the temperature effectively detected by the delivery sensor

Press "**WATER**". The following screen is displayed:

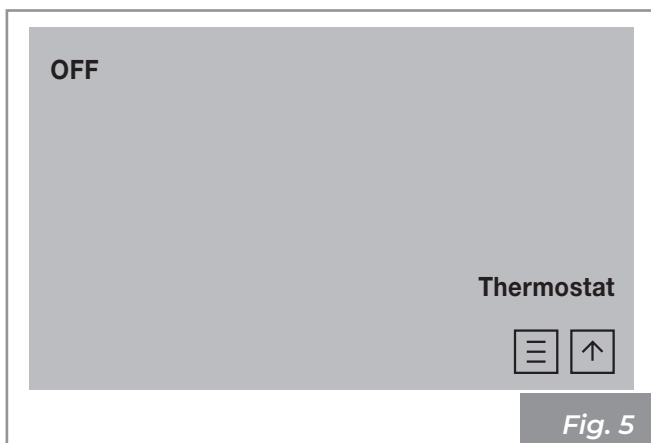

Press "**Thermostat**" to return to the previous screen.

Configuration 2 - Room sensor

Start screen

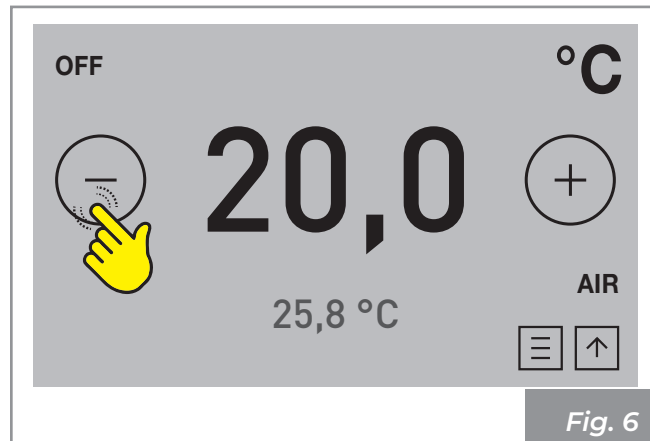

This screen displays the room temperature.

Press icons \oplus or \ominus to change the desired room temperature (large digits).
The value can be set between 10°C and 40°C.

The small digits display the room temperature detected by a sensor positioned on the device

Press "**AIR**". A screen opens displaying the delivery temperature of the boiler hot water:

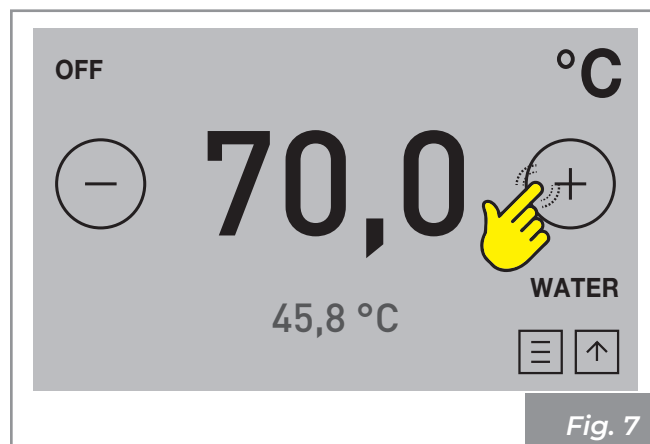

Press icons \oplus or \ominus to change the desired delivery temperature (large digits)
The value can be set between 45°C and 80°C.

The small digits display the temperature effectively detected by the delivery sensor

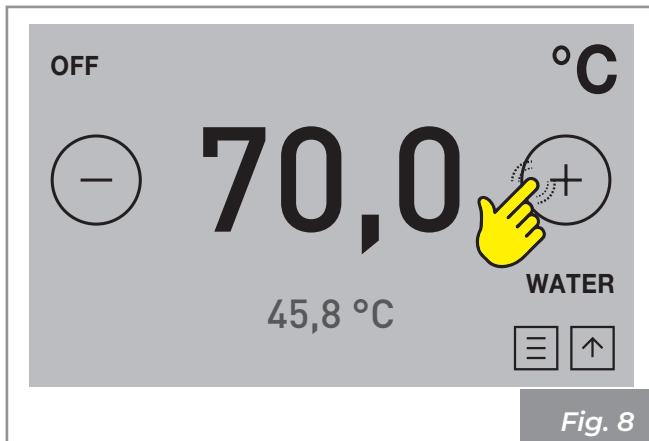
Configuration 3/4 - Accumulator with/without coil*Start screen*

This screen displays the temperature of the hot water inside the accumulator.

Press icons ⊕ or ⊖ to change the desired temperature inside the accumulator (large digits)
The value can be set between 45°C and 80°C.

The small digits display the temperature effectively detected by the sensor in the accumulator.

2 PRELIMINARY OPERATIONS

2.1 Pellet loading

The first operation to perform before switching the stove on is to fill the fuel (pellet) tank using the relevant scoop.

Do not empty the bag directly into the tank to avoid introducing sawdust or other foreign elements that could prevent the device from working properly and avoid scattering pellets outside the tank.



Indication: Be sure to close the lid of the tank well after loading the pellets. An "IS" safety switch (in certain models only) checks for correct closure and sends an alarm if the lid is left open for more than one minute with the device running.

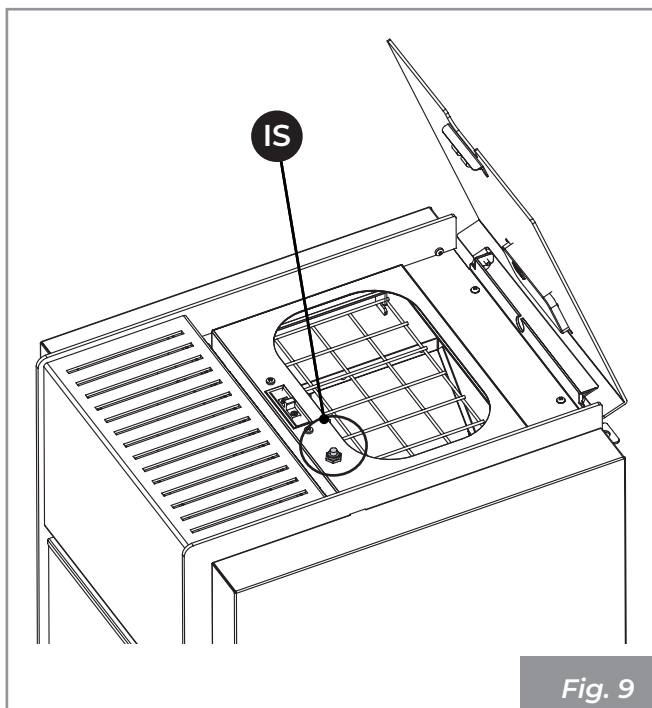

Fig. 9

2.2 Electrical power supply

Connect the device to the mains, flick the power switch at the back of the device to the "I" position.



Fig. 10

If the connection is properly made, the device emits a series of intermittent acoustic signals and the display turns on.



Attention: During long periods of non-use, we recommend turning the switch on the back of the device to the OFF (O) position.



Indication: Do not touch the control panel when the device is being powered up.

When the device is powered up the logo appears on the screen.



Fig. 11

After a few seconds the start screen appears:

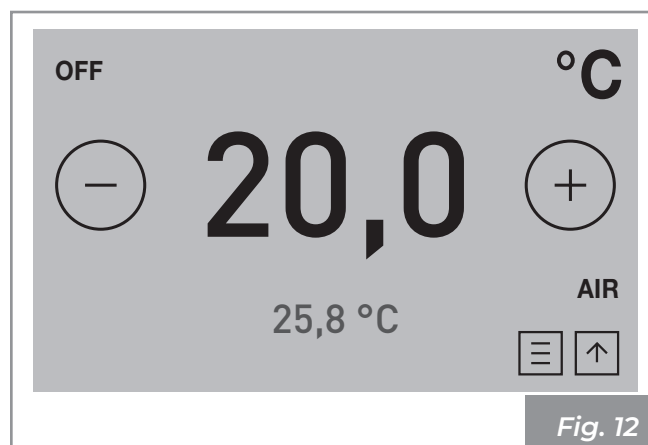

Fig. 12

3 SETTINGS MENU

3.1 Settings

Press the icon  to access the settings menu.

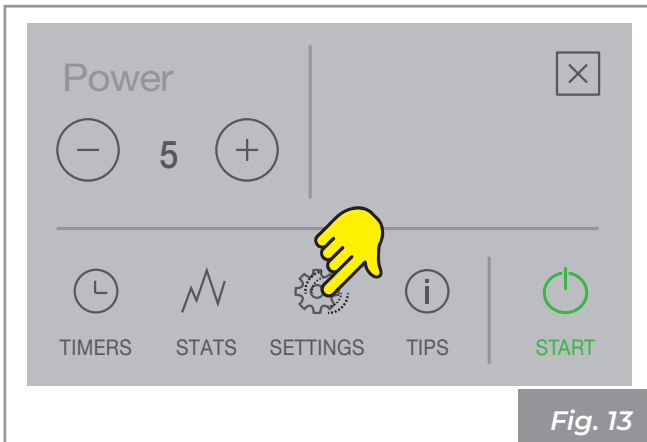





Fig. 13

Press  and  to scroll through the list of parameters.

Press the desired parameter to open the modification screen for that parameter.

The parameter settings can normally be changed by pressing icons  or .

Press  to confirm or  to close the modification screen without saving.

List of parameters

Parameter	Description	Settable values	Default values
Time	Time setting	Date and Time set correctly	
Date	Date		
Fuel	Three different combustion configurations can be set	1 ... 3	1
Eco Mode *	Enable Eco Mode	ON; OFF	<input type="checkbox"/> ON
Antifreeze *	Minimum temperature below which the device turns on	OFF; 3 ... 20 °C (OFF; 3 ... 50 °C)	OFF
Display options	Sets the brightness and information to be shown on the display in idle mode		
Temperature unit	Unit of measure of temperature	°C ... °F	°C
Speaker volume	Sets the volume level	OFF; 1 ... 5	2
Time to service	Displays the number of hours until maintenance is required.		2016 h
Installer menu	Changes/Displays the configuration of the device	PWD: "54"	
Service menu	Assistance centre menu		
Screen lock	It sets the key lock mode	OFF; LOW; HI	OFF
Language	Sets the display language:	English Italian German Spanish French Portuguese Bosnian Slovene Swedish Dutch Romanian	English
Info	Displays the system information		

(*) Parameter available only in certain configurations

3.1.1 "Time" setting

To set the time:

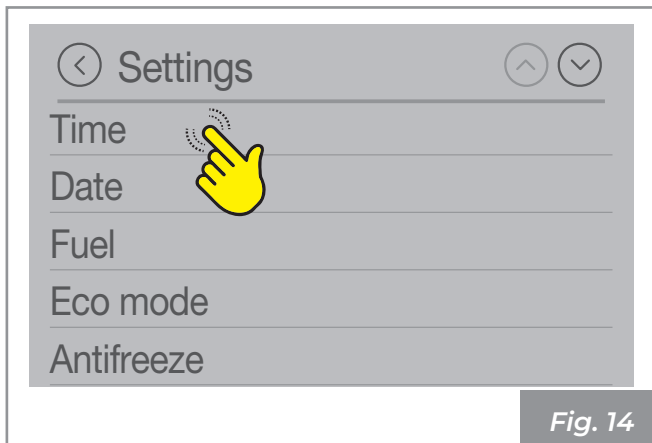

Fig. 14

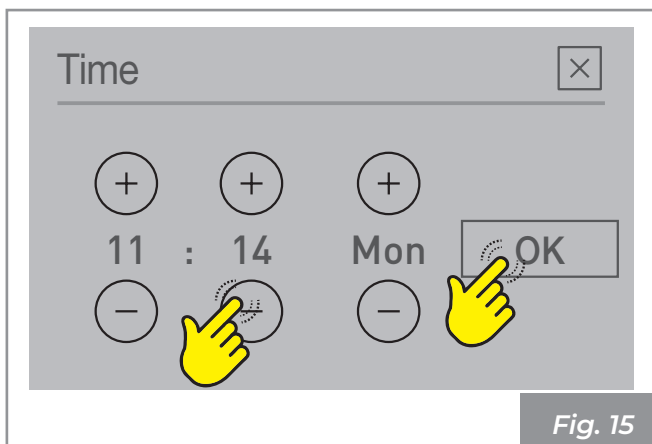

Fig. 15

3.1.2 "Date" setting

To set the date:

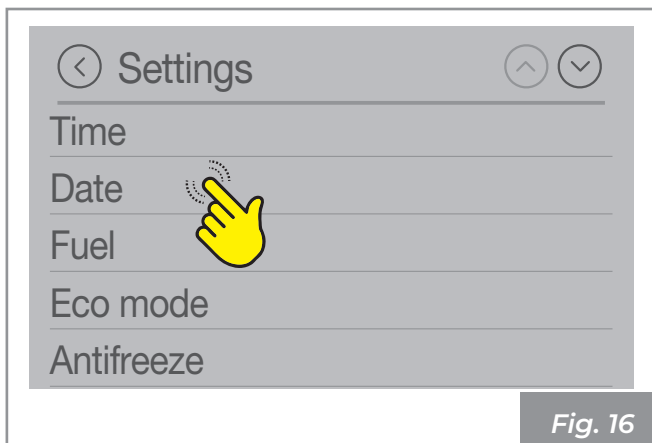

Fig. 16

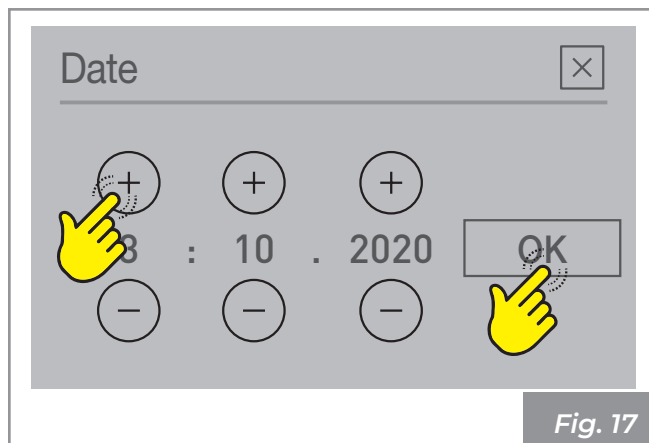

Fig. 17

3.1.3 "Fuel" function

Excellent fuel depends on different factors (type of installation, operating and maintenance conditions, type of pellets, etc.)

Generally speaking, if at the end of combustion, there is a lot of residue in the burn pot, you should change the combustion configuration (by increasing the value) until you find the best solution.

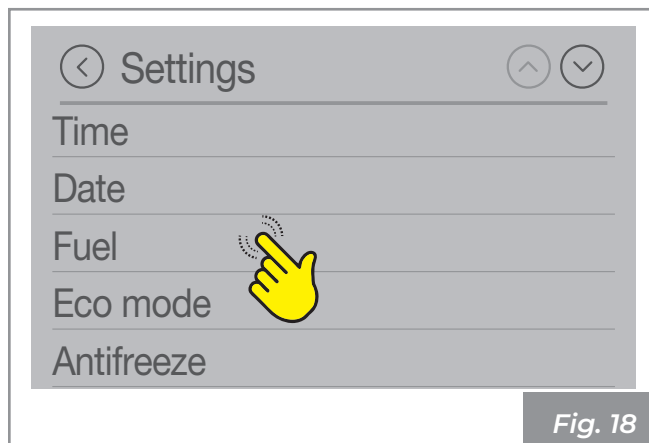

Fig. 18

Optimisation of combustion:

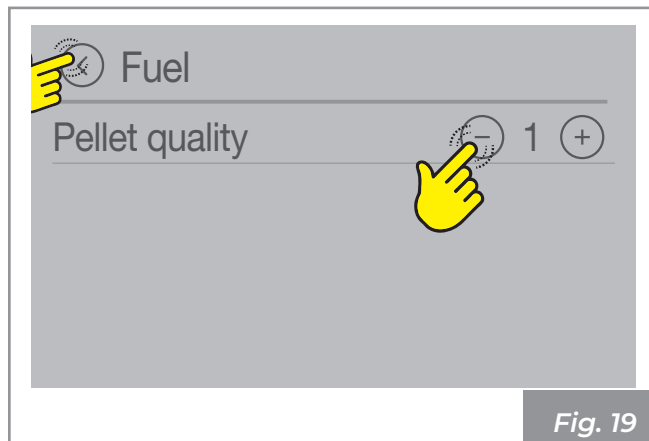

Fig. 19

The values can be set from 1 to 3.

- 1) High quality pellets (En Plus)
- 2) Medium quality pellets
- 3) Low quality pellets

3.1.4 "Eco mode" function

Function available in configuration 2 only.

By enabling this function, the device is turned off when the desired room temperature is reached. If this function is not enabled, the device modulates its operation without shutting down.

To activate/deactivate this function:

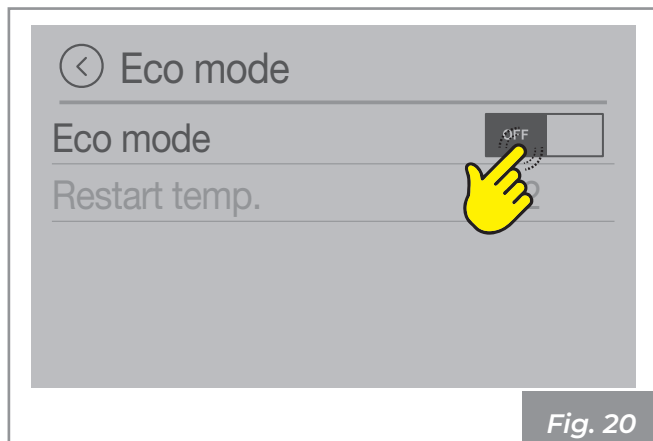

Fig. 20

	"Eco mode" function inactive
	"Eco mode" function active

When the "Eco mode" function is activated, the "Restart temp." option becomes available, which is the number of degrees below the set temperature after which the device automatically restarts.

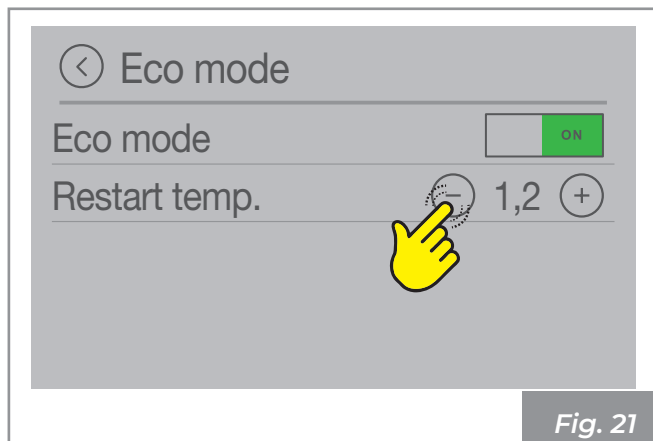

Fig. 21

Example: if the device is set to shut down at 20°C ("Eco mode" function active) and we set a "Restart temp." of 4°C, the device will turn on again when it detects a temperature less than or equal to 16°C.

The values can be set from 0.5 ... 5.0 °C.

3.1.5 "Antifreeze" function

Function available in configurations 2, 3 and 4 only.

A minimum temperature can be set below which the device will switch on (outside the set time bands and only if the timer is enabled).

To modify the "antifreeze" temperature value:

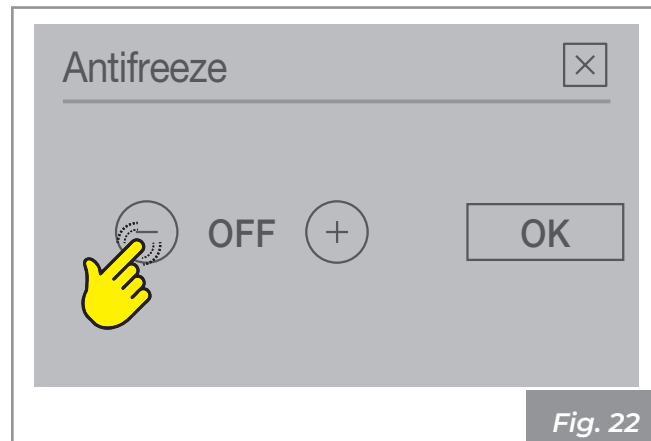

Fig. 22



Fig. 23

Settable values:

(OFF; 3 ... 20°C) for configuration 2

(OFF; 3 ... 50°C) for configurations 3 and 4

3.1.6 Display

Press “Display options” to change the characteristics of the display view.

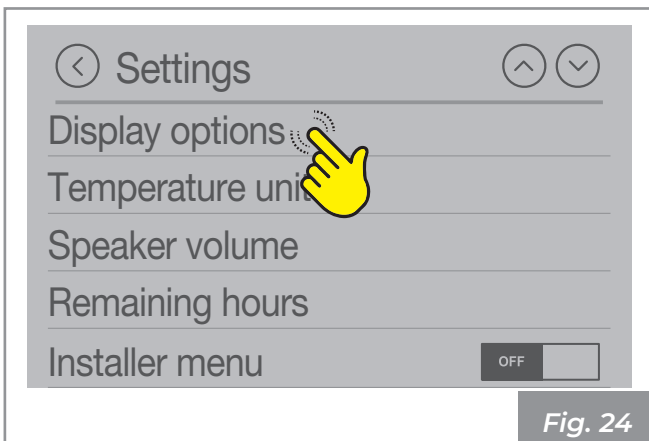

Fig. 24

Display brightness

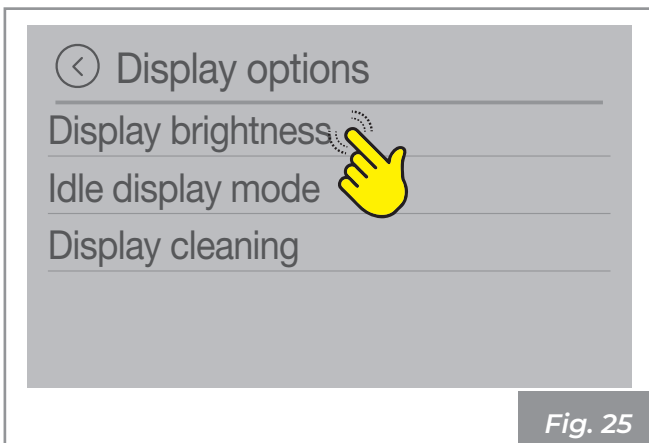

Fig. 25

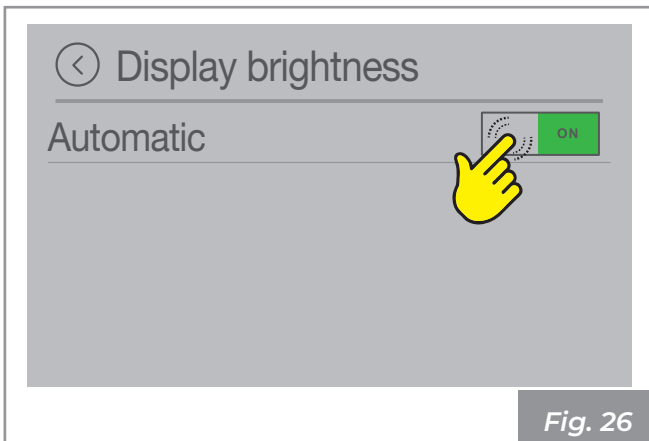

Fig. 26

Automatic: self-adjusts according to the brightness sensor

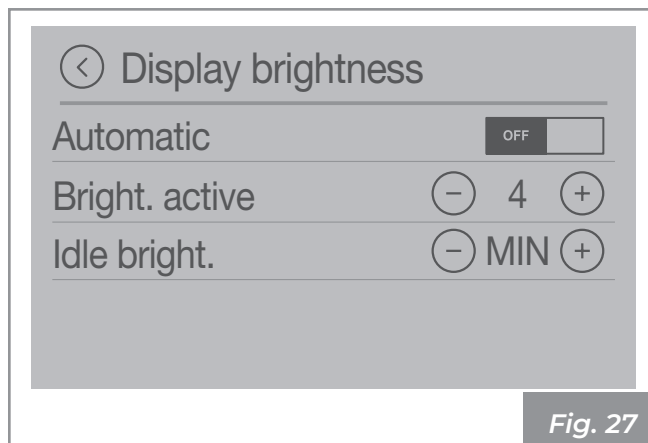

Fig. 27

Active display brightness: from 0 to 100% brightness

Settable values: MIN - 2 - 3 - 4 - MAX;

Idle display brightness: from 0 to 50% brightness

• OFF

• MIN - 2 - 3 - 4 - MAX

In the OFF position the display turns black after 60 seconds of non-use, tap to reactivate.

Display in “Idle disp. mode”

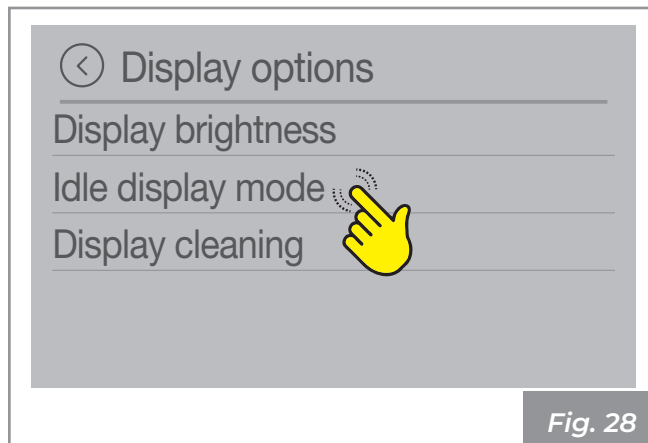

Fig. 28

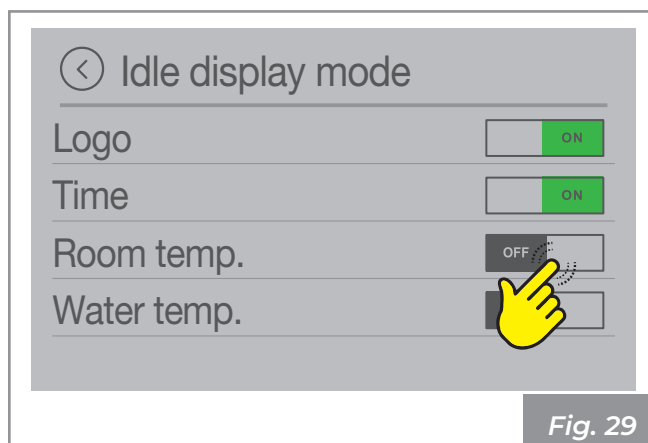

Fig. 29

It is possible to select which information is viewed when the display is in idle mode:

- Logo
- Time
- Room temperature
- Water temperature

Example of cyclically alternating screens in idle display mode:

Time and date

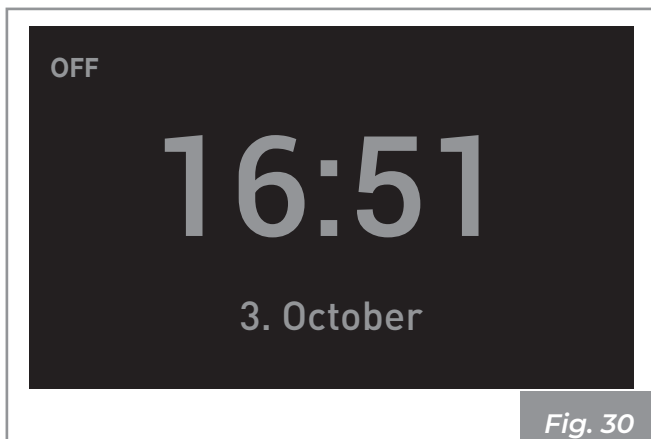

Fig. 30

Room temperature

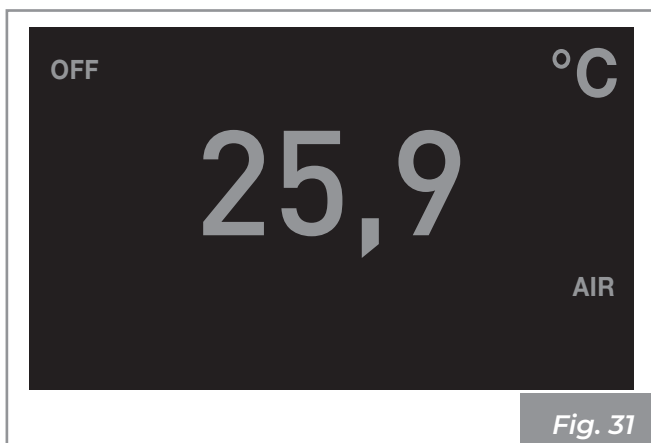

Fig. 31

3.1.7 "Cleaning" function

Setting to clean the display

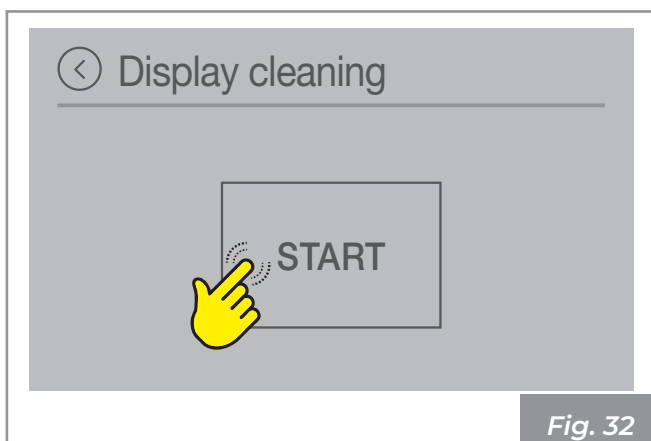

Fig. 32

Press "START": a countdown starts; the acoustic BEEP signal indicates that the display is inactive and it can therefore be cleaned without interfering with its functions.

At the end of the countdown the touch screen returns to active mode.

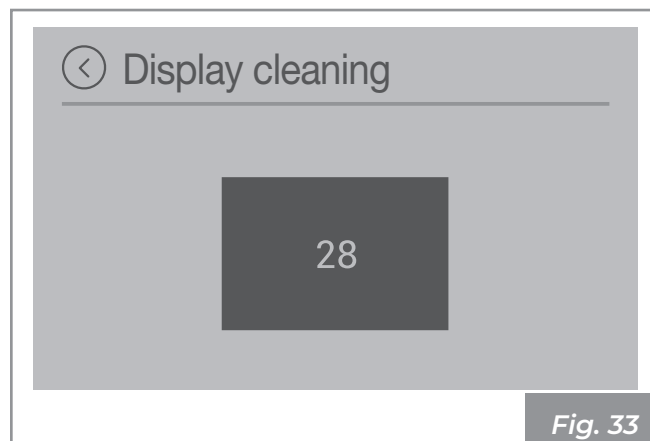

Fig. 33

3.1.8 "Temperature unit" setting

To change the unit of measure of temperature:

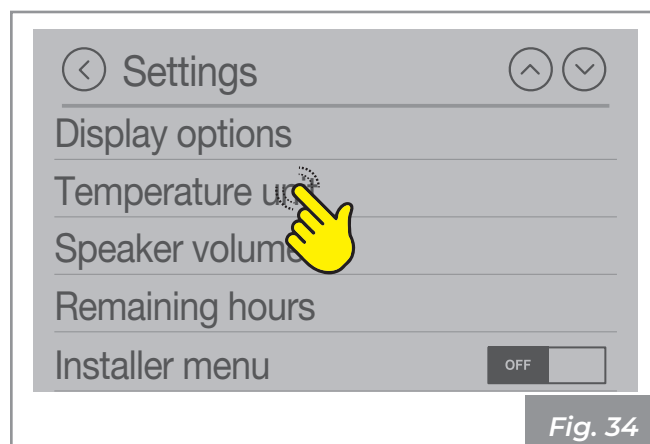

Fig. 34

To change from °C to °F press ⊕ or ⊖.
Press to confirm.

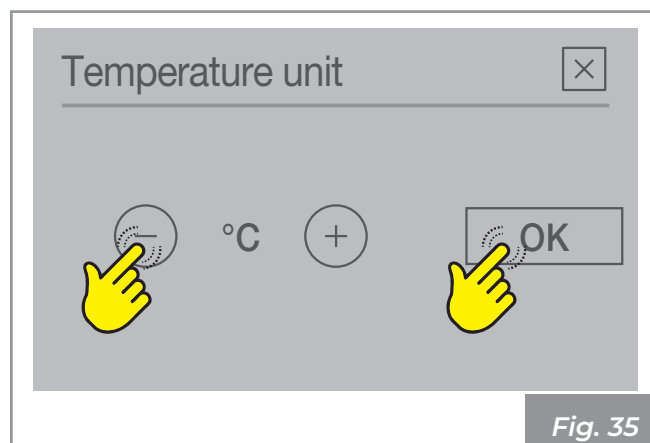

Fig. 35

3.1.9 “Speaker” setting

To change the intensity of the speaker:

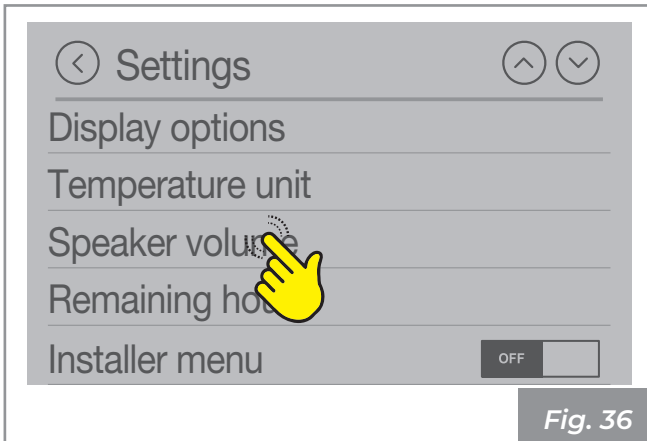

Fig. 36

Press **+** and **-** to set the desired volume level (OFF, 1 ... 5).
Press **OK** to confirm.

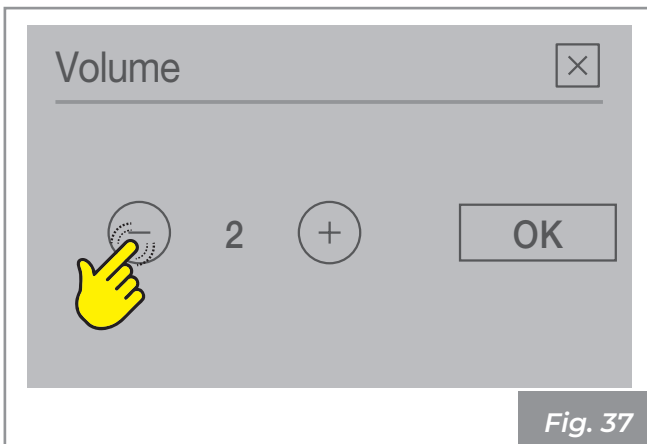

Fig. 37

3.1.10 “Time to service” function

Indicates the amount of time remaining until the next scheduled maintenance.

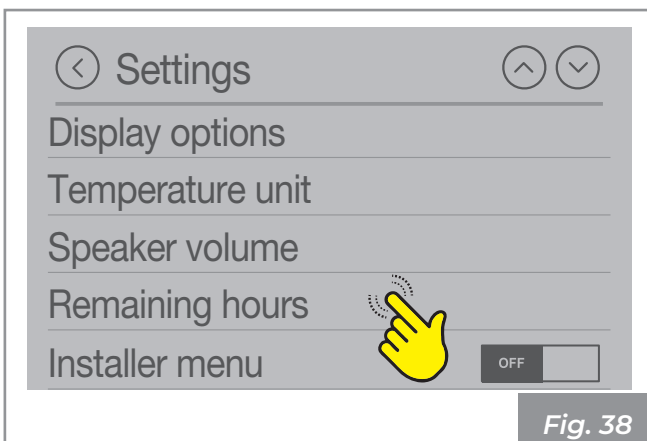

Fig. 38

Displays the number of hours until maintenance is

required.

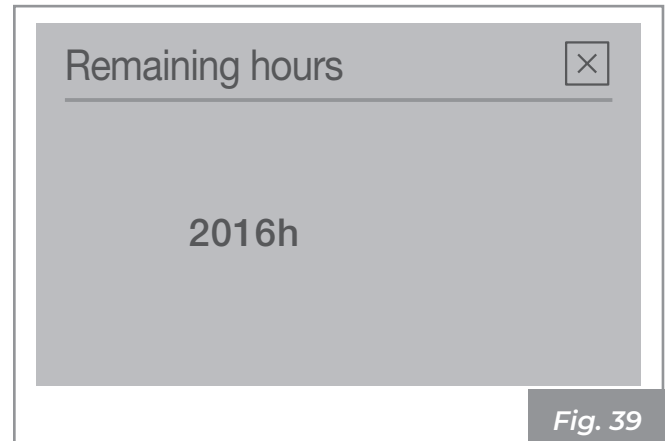

Fig. 39

3.1.11 Installer Menu



Hazard: The submenus are password-protected and are reserved to the service centre.

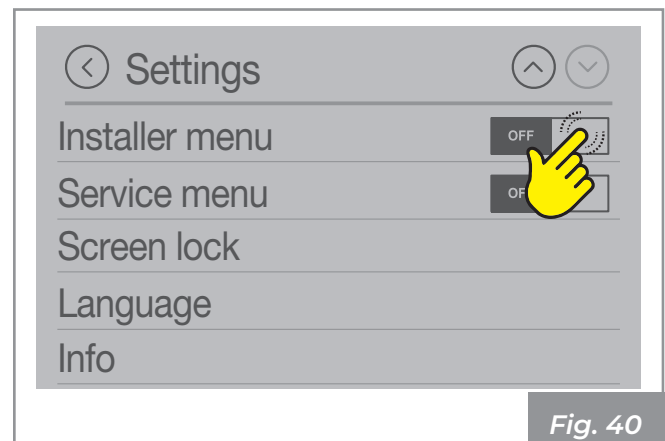

Fig. 40

Press **ON**: the password appears, set **54** and press **OK** to confirm.

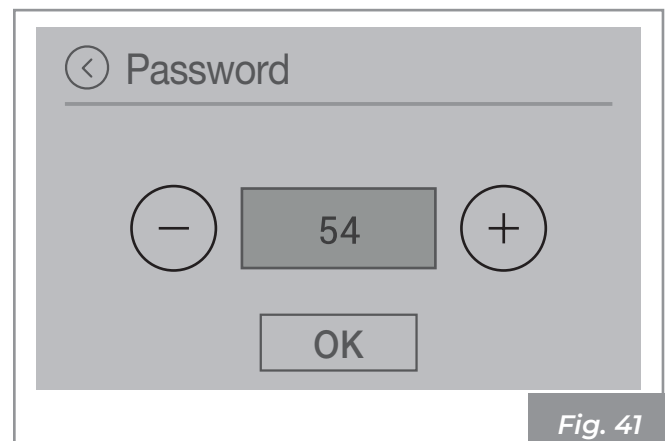

Fig. 41

Press "**Configurations**".

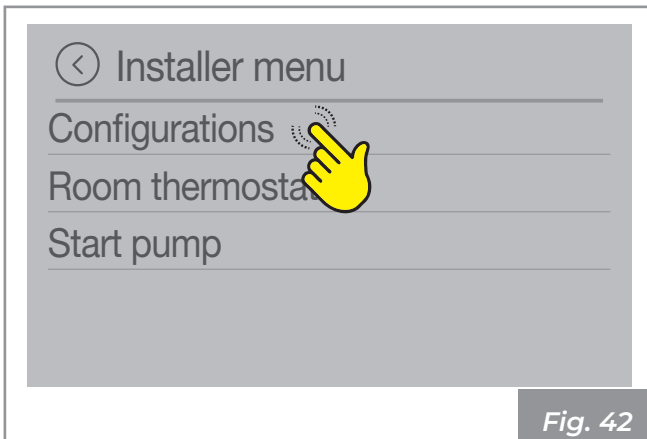

Fig. 42

The possible device configurations are displayed. The current configuration is shown as ON, all the others are OFF.

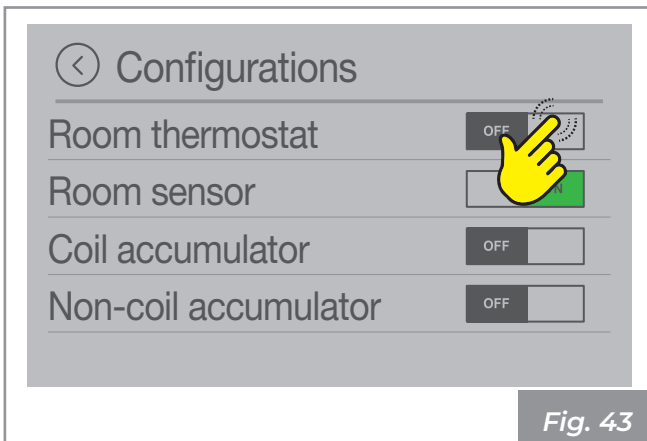

Fig. 43

Configu-ration	Description	Default
1	External thermostat	OFF <input type="checkbox"/>
2	Room sensor	<input checked="" type="checkbox"/> ON
3	Accumulator with coil	OFF <input type="checkbox"/>
4	Accumulator without coil	OFF <input type="checkbox"/>

See *system configuration* in the *installation manual*.

3.1.12 Service menu



Hazard: The submenus are password-protected and are reserved to the service centre.

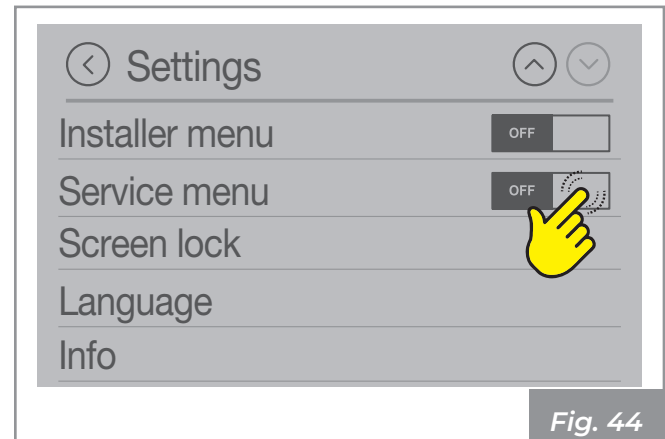

Fig. 44

3.1.13 "Screen lock" function

To block access to the display functions:

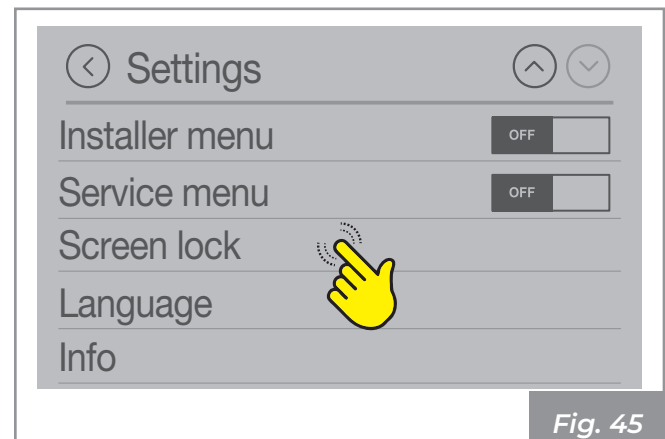

Fig. 45

- **OFF** : Screen lock deactivated
- **LOW** : Partial screen lock
- **HI** : Screen lock activated

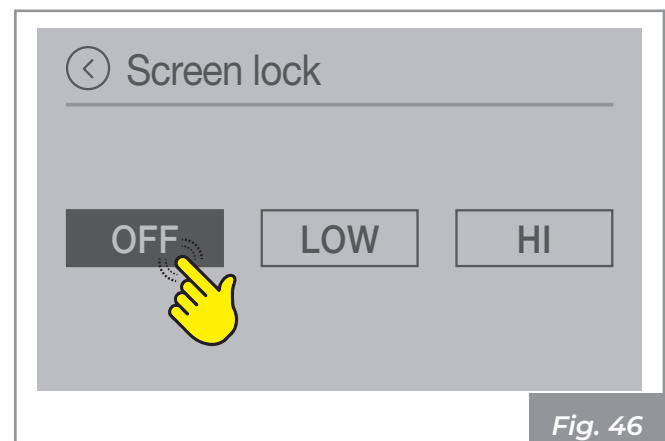

Fig. 46

To disable the function select "Screen lock" and set it to **OFF**.

3.1.14 Language

To set the language:

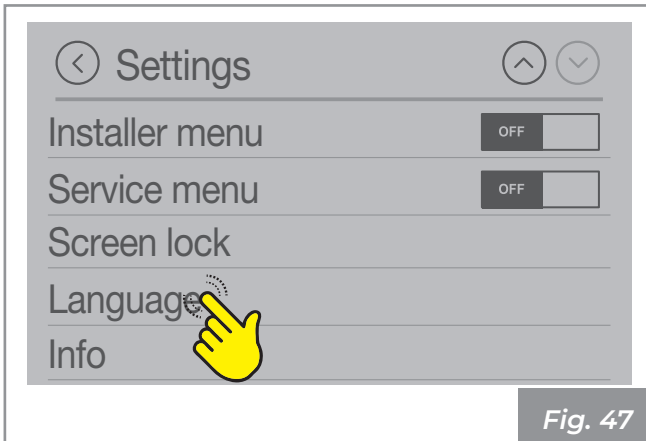

Fig. 47

3.1.15 Information

To display the system information:

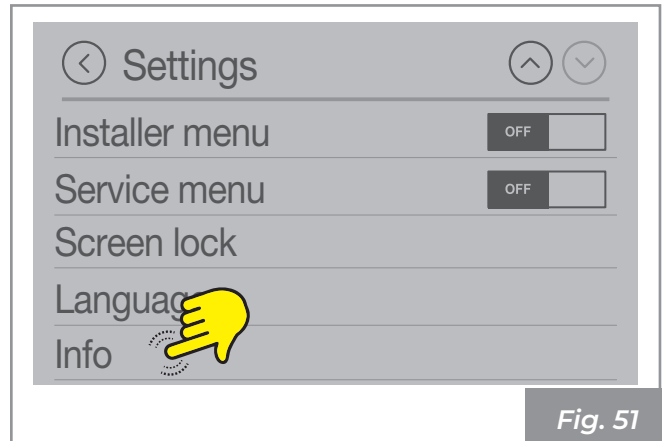

Fig. 51

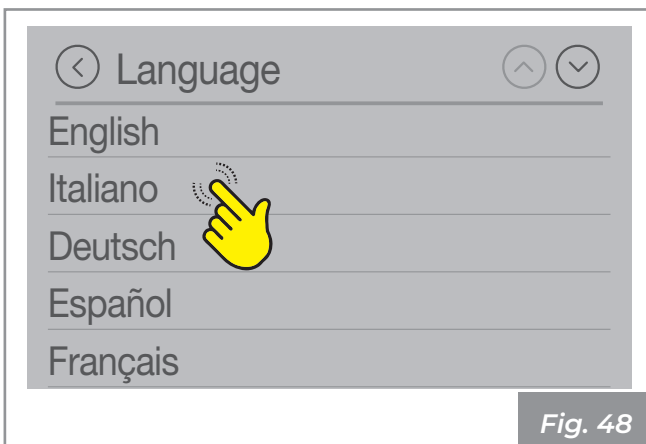

Fig. 48

Displays the current software version.

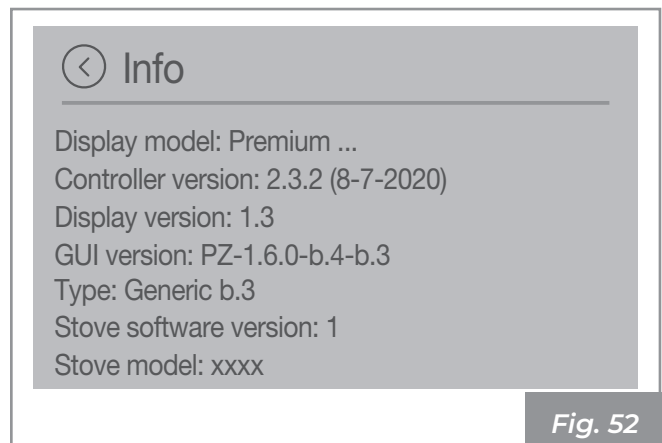

Fig. 52

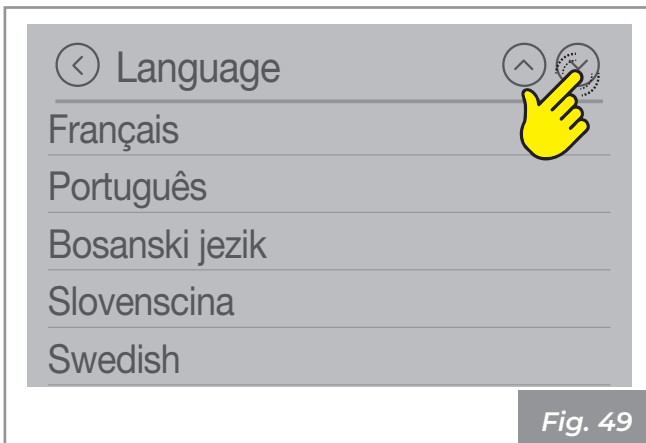

Fig. 49

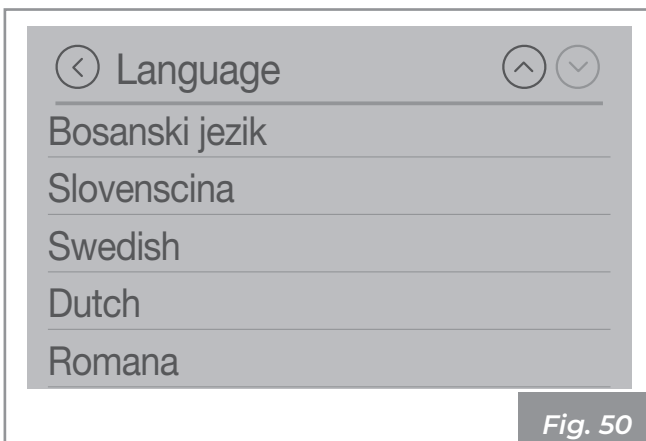

Fig. 50

4 USE

4.1 Ignition



Hazard: Before each ignition, make sure that the burn pot is completely empty and correctly positioned in its seat.

There are two ways to ignite the device.

First mode:

Press the icon 

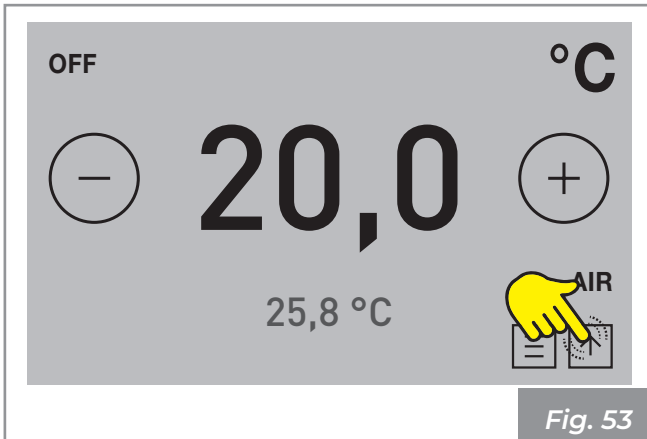

Fig. 53

Hold the icon pressed for two seconds to ignite the product.

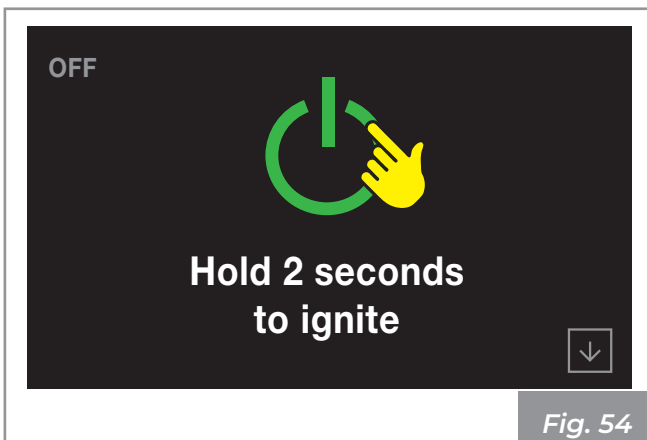

Fig. 54

Second mode:

Open the main menu and hold START pressed for a few seconds.

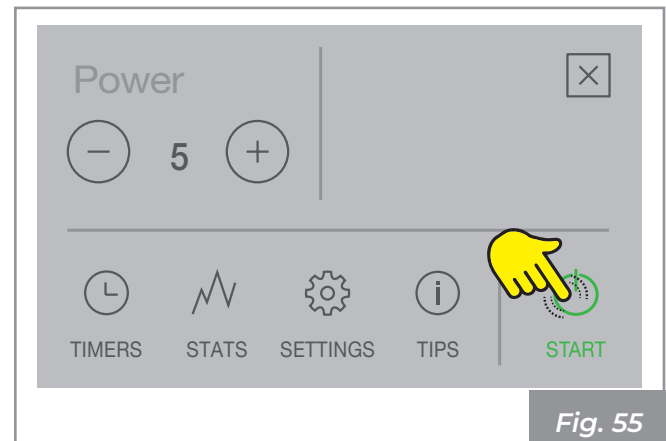

Fig. 55

The device will now start the ignition phase. The following sequence is displayed:

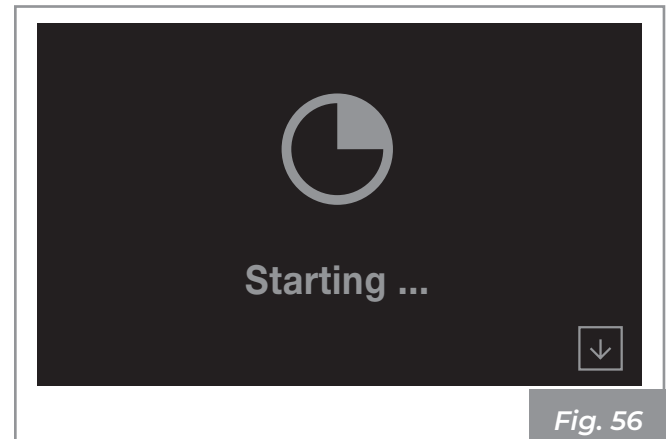

Fig. 56

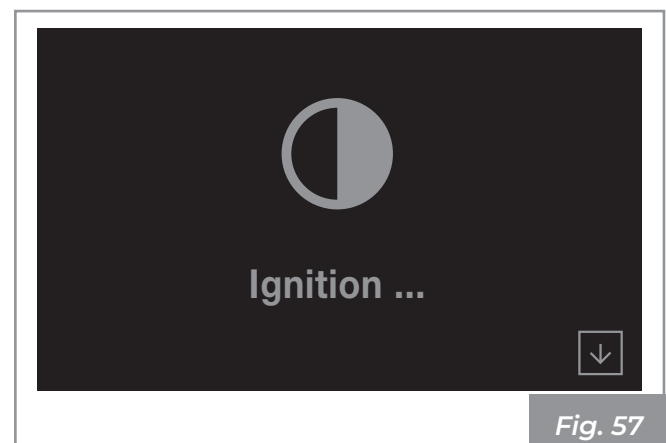

Fig. 57

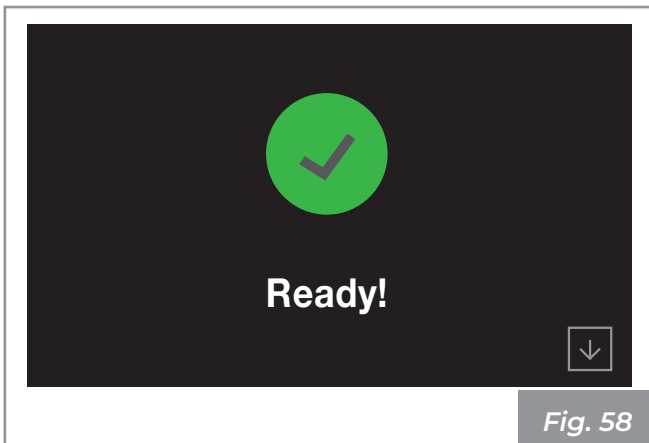

Fig. 58

After a few seconds the start screen appears:

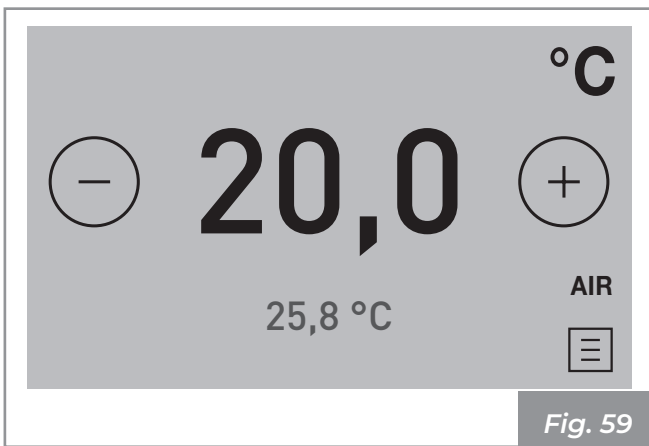

Fig. 59

Attention: Automatic ignition: the device is equipped with an automatic device that allows pellet ignition without the use of other traditional ignitors.



Hazard: Do not manually ignite the device if the automatic ignition system is faulty.



Attention: During the first ignition of the device, unpleasant odours or fumes may be generated due to the evaporation or drying of certain materials used. This phenomenon will gradually disappear. During the first ignitions, it is advisable to keep the premises well ventilated.



“Hermetic” series devices:

Do not leave the fire box door open for prolonged periods whenever you open it to avoid setting off an audible alarm when the closure sensor detects the door open status.

4.1.1 Modifying the room temperature

By changing this value, the desired room temperature is set, detected directly by a sensor located on the device.

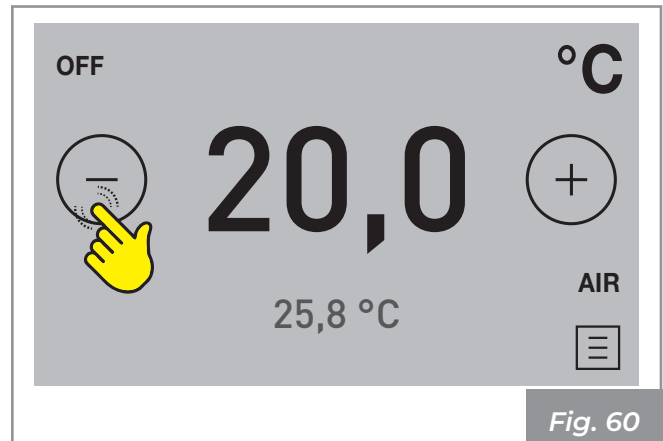

Fig. 60

To change the temperature press icons ⊕ or ⊖: The value can be set between 10°C and 40°C.

4.1.2 Modifying the power

The power defines the quantity of heat produced by the device and therefore also directly affects consumption.

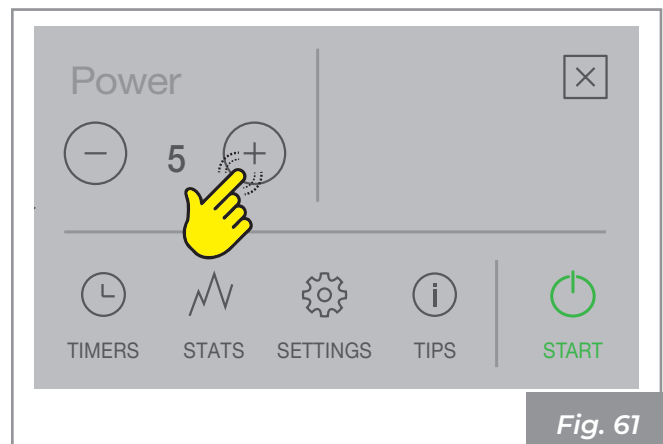

Fig. 61

To change the power level press icons ⊕ or ⊖: The value can be set between 1 (minimum) and 5 (maximum).

4.2 Modifying the parameters

The operating parameters can be modified according to the procedure described in chapter “3 Settings menu”



Indication: The set values will be saved until the next variation, even if the device is shut down or disconnected from the power supply.

4.3 Shutdown

To shut down the device hold the STOP key pressed for a few seconds;

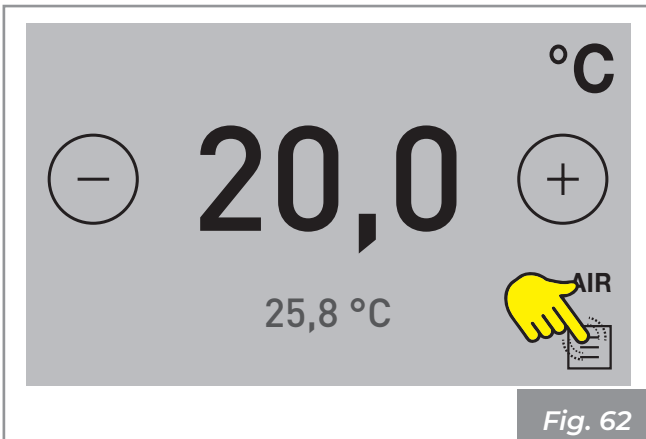

Fig. 62

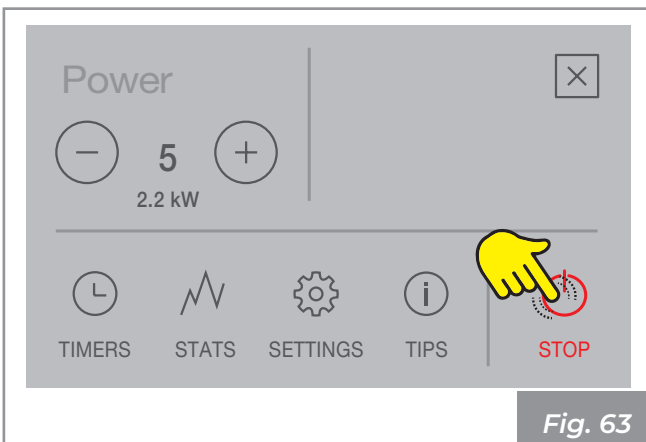

Fig. 63

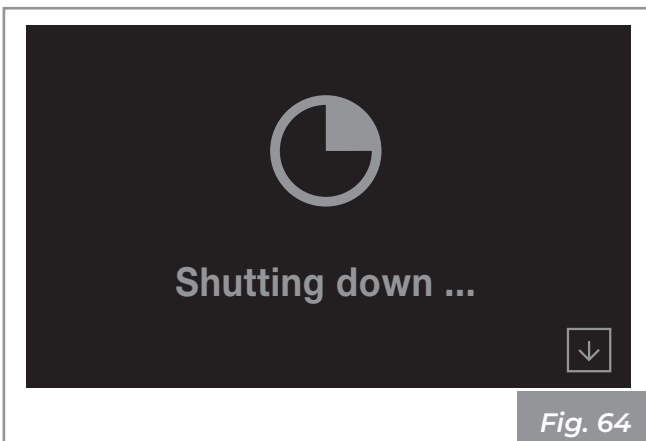

Fig. 64

If the temperature is still high, a cooling phase begins:

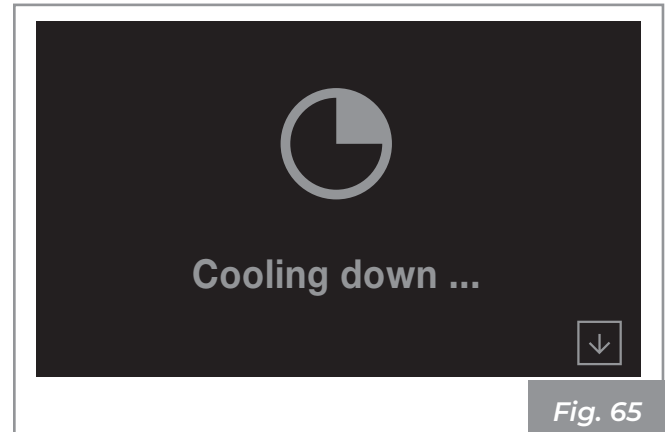

Fig. 65



Indication: It is recommended to wait for the device to completely cool down before restarting it.



Hazard: The device must be turned off strictly following the above instructions. It is prohibited to shut down the device by cutting off the power supply.

4.4 Restart after a power failure

In the event of a power failure, the device will automatically switch back on, verifying the safety conditions, when the power supply returns.

4.5 Operation with external thermostat

When the device is controlled by an external thermostat (or programmable thermostat), the installer must have set **configuration 1**.

In this case the device shuts down when the external thermostat is satisfied (open circuit). The device automatically restarts when the temperature drops below the value set on the external thermostat (closed circuit).



Indication: During the first ignition, or if shutdown is prompted directly from the device, the latter must be ignited directly from the control panel.

4.6 Operation with room sensor on stove

The device can be turned on/off either manually or according to a program.

The device modulates the power based on the room temperature detected by the on-board sensor (it tries to maintain the desired temperature, consuming as little as possible).

If the user has enabled the "Eco-mode" function, instead of modulating, the device shuts down when the set temperature is reached and restarts when the room temperature falls below the set delta (see section "3.1.4 "Eco mode" function").

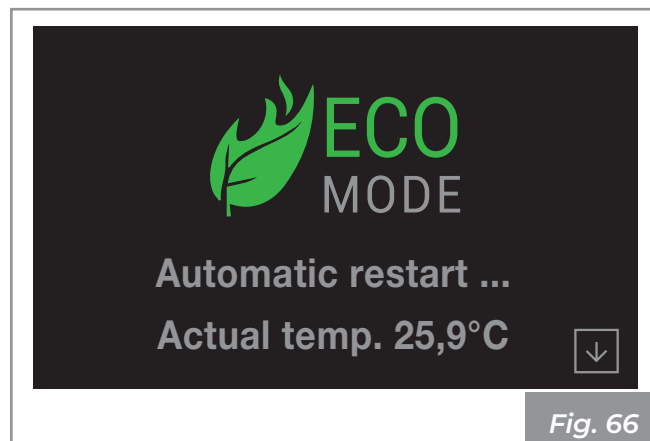

Fig. 66

5 AVAILABLE FUNCTIONS

5.1 Timer setting

It is possible to set, enable and assign to the various days of the week, customised programs for the automatic ignition and/or shutdown of the device.

Up to six customised programs can be configured. For each program it is possible to set: start time, switch off time and desired temperature.

Up to three programs can be assigned to each day of the week.

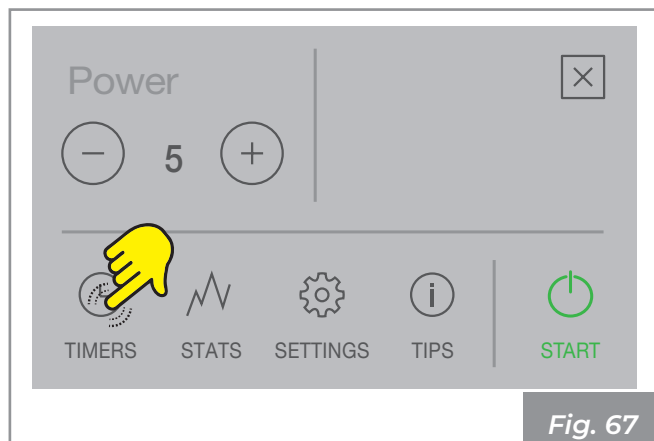

Fig. 67

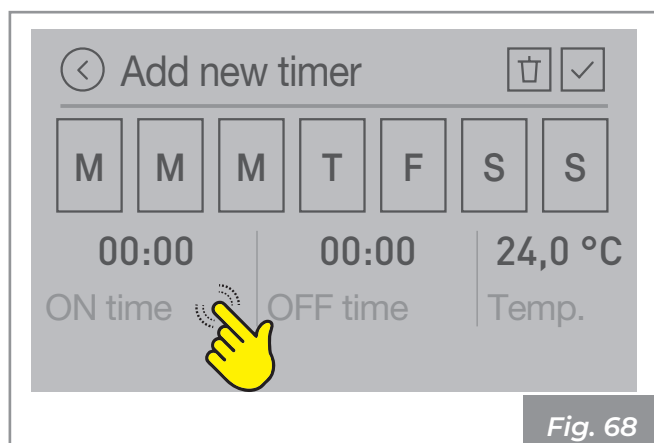

Fig. 68

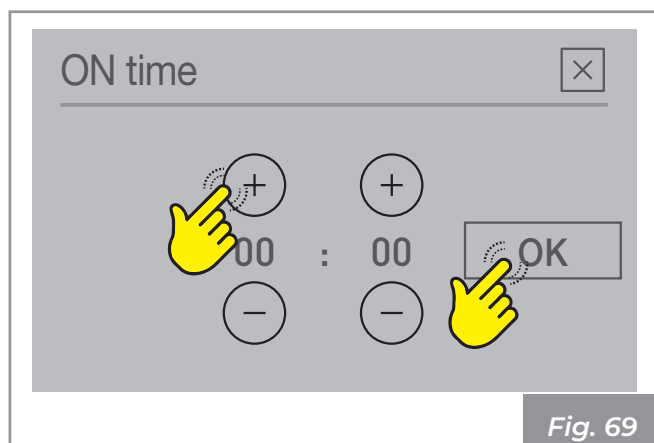

Fig. 69

Example of set Timer

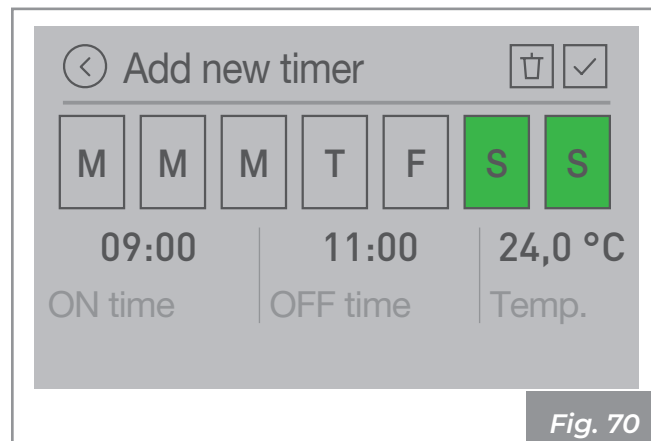

Fig. 70



Indication: The settable temperature on the timer depends on the type of system configuration. For more information see section "1.4 Start screen and set temperature".

5.1.1 Timer enabling/disabling

Select ON to enable the timer or OFF to disable it.

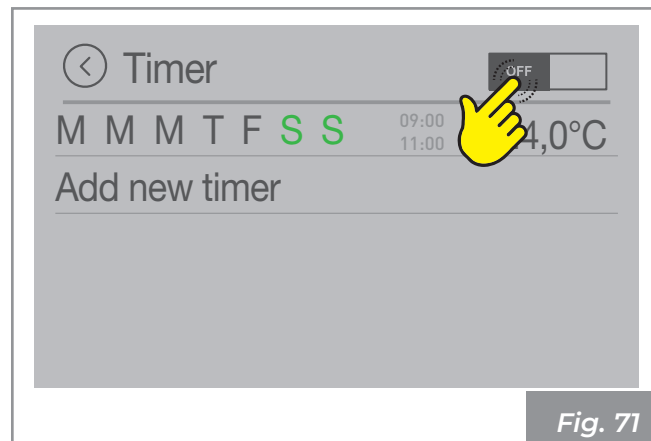

Fig. 71

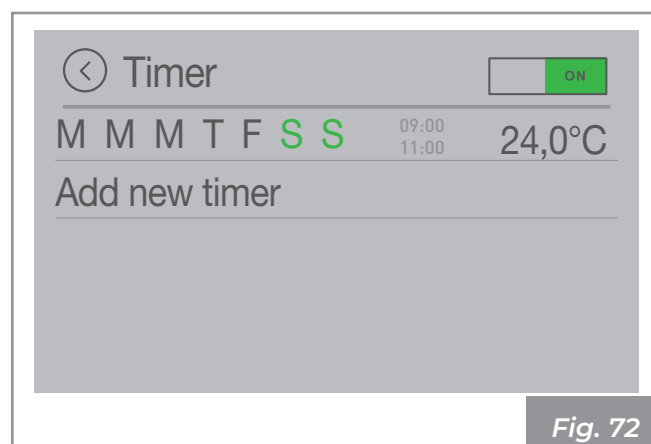

Fig. 72

The device will ignite at 9.00 am and shut down at 11.00 am on Saturdays and Sundays

5.2 Statistics

It is possible to view a log of the device's statistics.

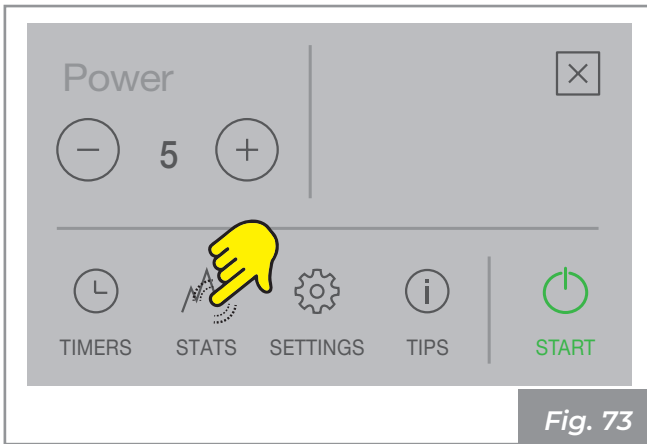

Fig. 73

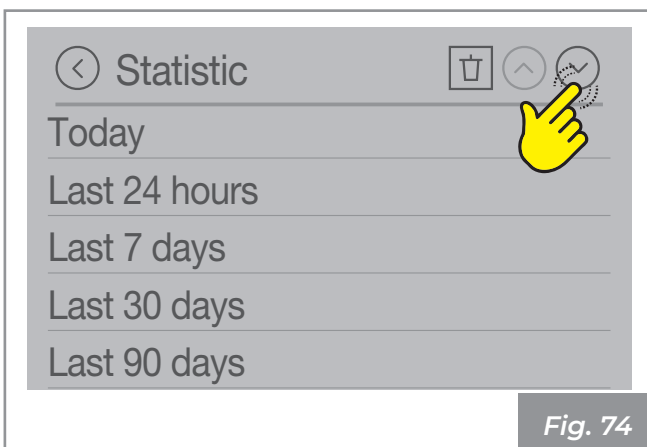

Fig. 74

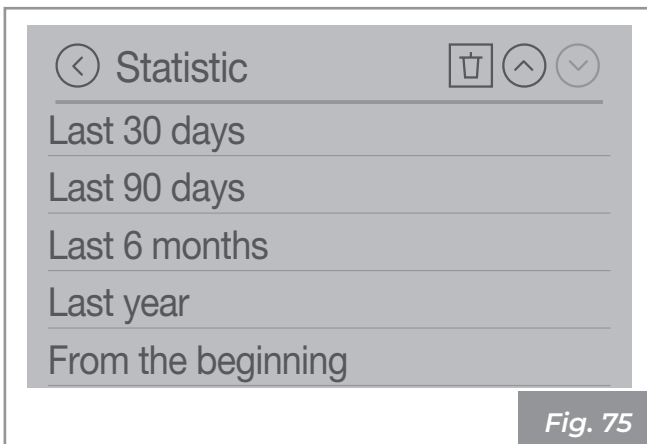

Fig. 75

Example statistics

By selecting "Today" we can view:

- the kilograms of pellets used
- the heating time
- the average power produced
- the average room temperature

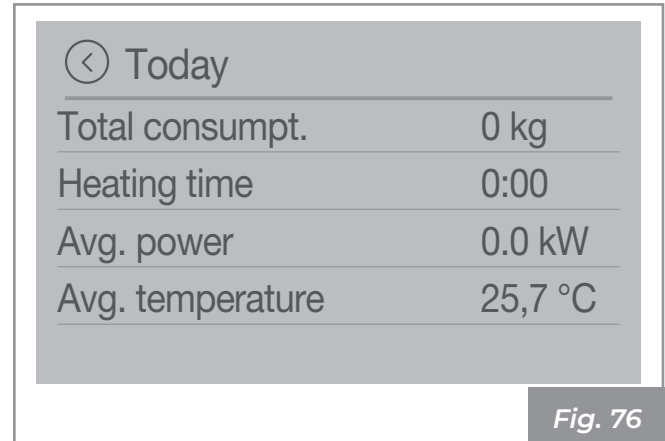

Fig. 76

Delete statistic

Press the icon  to delete the statistic:

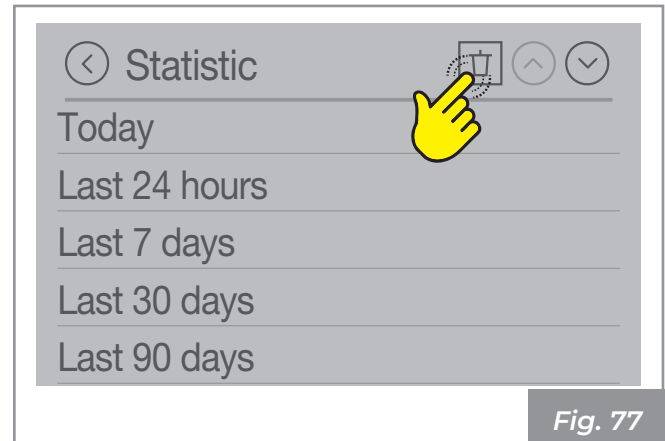

Fig. 77

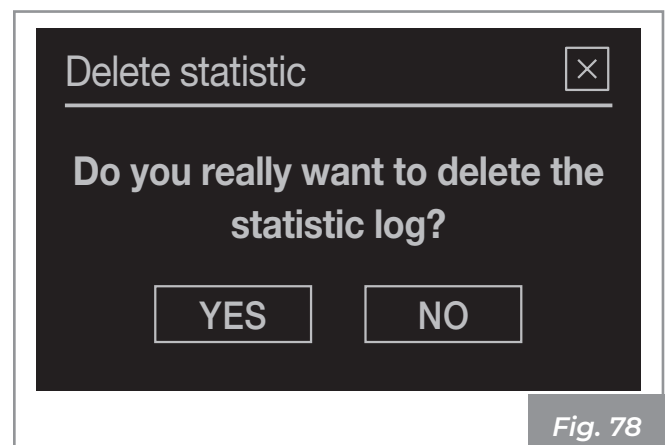

Fig. 78

5.3 Operating tips

This menu is used to provide simple tips on how to get the most out of the product.

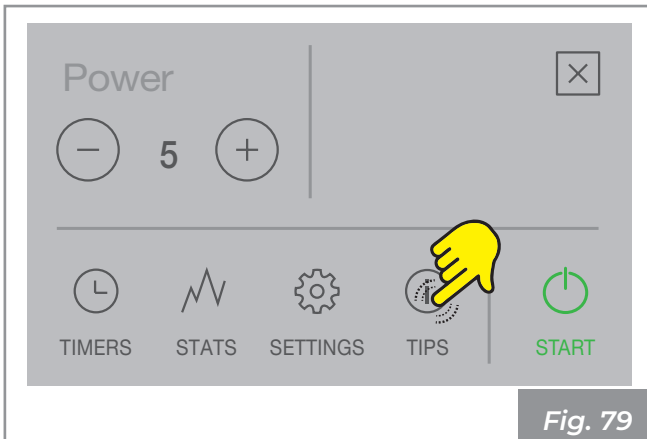

Fig. 79

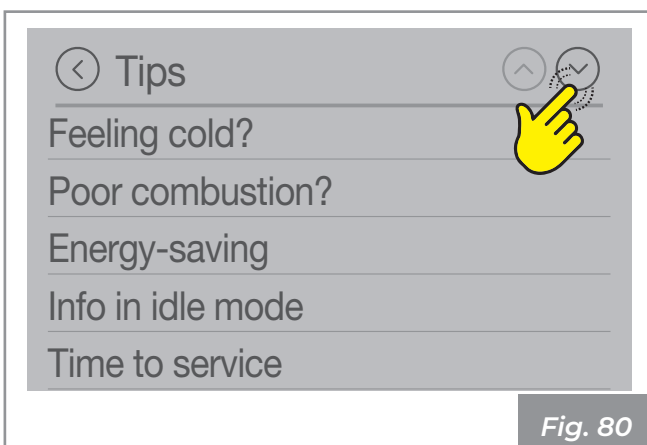

Fig. 80

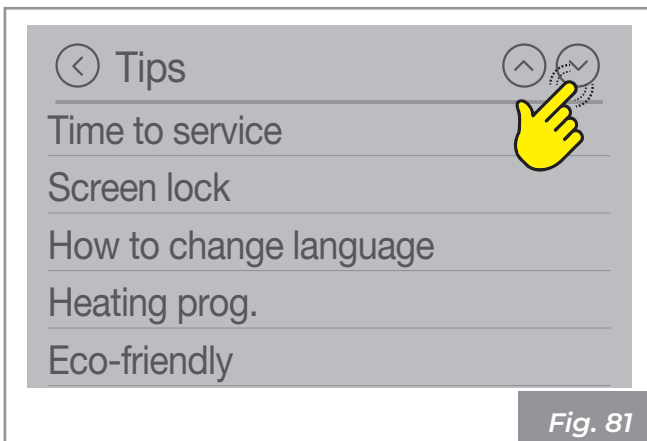

Fig. 81

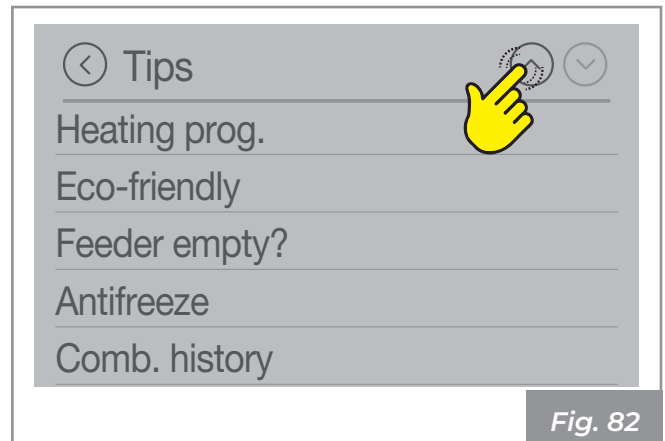

Fig. 82

6 TROUBLESHOOTING

When an operating error occurs, an acoustic alarm (beep) is automatically emitted and the possible cause appears on the display with a numeric error code.

The errors are categorised into:

- **Alarms** **E**: blocking errors. The device shuts down. The cause of the alarm must be resolved before the device is restarted.
- **Warnings** **!**: simple notifications that do not block the operation of the device (in some cases operation may be limited). They are automatically reset once the cause is eliminated or resolved.

Example display of Alarm E102:

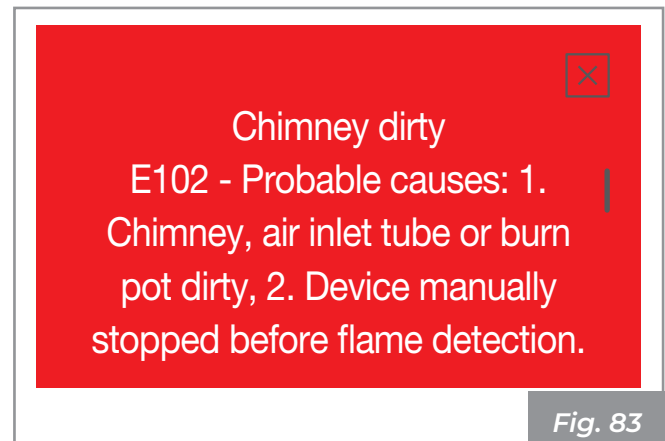

Fig. 83

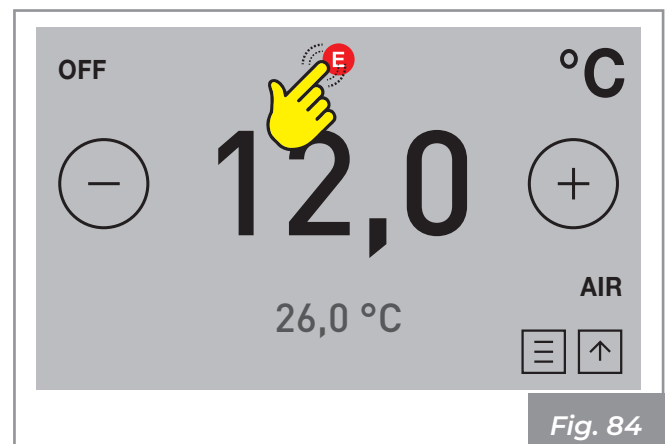

Fig. 84

6.1 Description of alarms

Alarm code	Description	Possible causes
E002	IR communication error	Infrared sensor not working. Call service..
E004	MB communication error	MB communication error
E101	Fire error	Missed firings
E102	Chimney dirty	1. The chimney or air inlet tube or burn pot need to be cleaned. 2. Manually stopped device before flame detection.
E104	Grate blocked	Empty and clean the grate. Reset the error.
E105	NTC2 error	Sensor connected to T02 malfunctioned or disconnected. Call service.
E106	NTC3 error	Sensor connected to T05 malfunctioned or disconnected. Call service.
E108	Safety switch error	Switch connected to I01 switched OFF. Reset the alarm and restart the device. If the error persists, call service.
E109	Pressure error	Pressure sensor or safety switch switched OFF. Reset the alarm and restart the device. If the error persists, call service.
E110	NTC1	Sensor connected to T01 malfunctioned or disconnected. Call service.

Alarm code	Description	Possible causes
E111	TC1	Sensor connected to T03 malfunctioned or disconnected. Call service.
E113	Gas over-temperature	Flue gas over-temperature. Clean the exchanger or chimney.
E114	Failed ignition	Fuel ignition timeout expired (empty the burn pot and restart the device) or fuel tank empty (refuel the tank).
E115	General error	Call service.

6.2 Reset alarms

In case of an alarm the display turns red and an acoustic signal (beep) is emitted.

The alarm code and possible cause is displayed. The device shuts down.

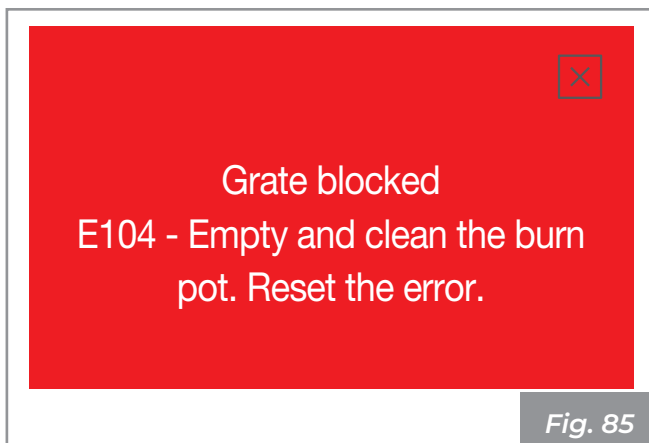

Hazard: In case of alarms "E108" or "E109", before resetting the alarm, reactivate the manual reset thermostat positioned on the back of the device (by the Technical Service Centre). At this point it is possible to proceed with a new ignition.

If the screen is closed by pressing  the alarm is not reset and the icon  remains.

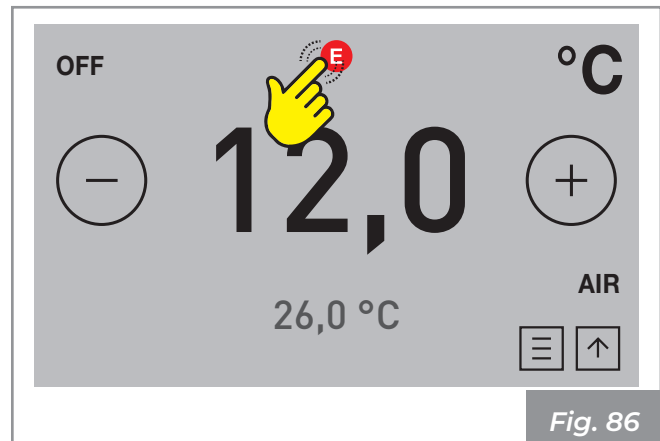

To see the alarm description again press the icon .

Before switching on again, check that:

- the device has cooled;
- the cause of the alarm has been resolved;
- the burn pot is clean and free from ash residue or pellets;
- the burn pot is correctly positioned in its seat;
- the fire box and tank doors are firmly closed.

6.3 Description of warnings

Warning code	Description	Possible causes - solutions
A001	Fuel low	Warning fuel level, refuel the tank.
A002	Maintenance	Service time expired, call service for maintenance.
A004	Low battery	Low battery, call service for replacement.
A005	Speed sensor	Speed sensor failure, call service.
A007	Pressure/airflow sensor	Alternative operating mode, limited functionality. Airflow sensor malfunctioned, call service.

6.4 Reset warnings

In case of a warning the display turns yellow and an acoustic signal (beep) is emitted. The warning code and possible cause is displayed.

To see the warning description again press the icon . The cause of the problem must be resolved to reset the warning.

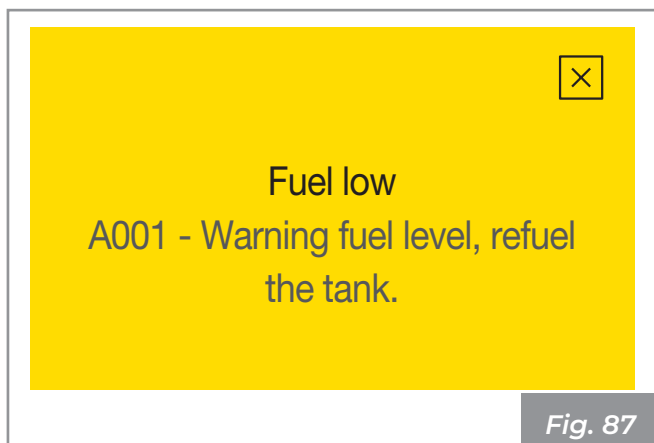

Fig. 87



Attention: In case of a warning the device remains operational (in some cases operation may be limited).

If the screen is closed by pressing  the warning is not reset and the icon  remains.

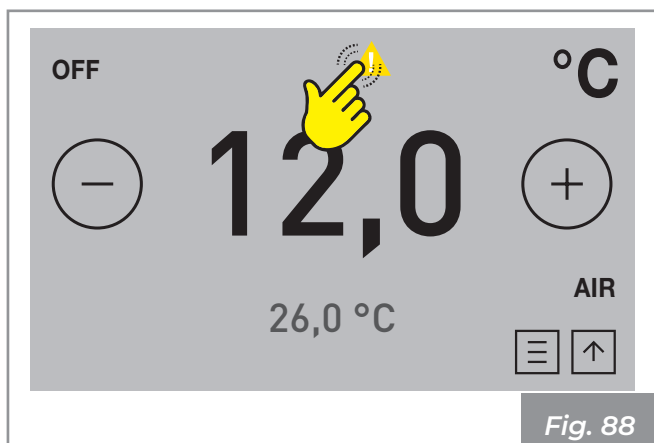

Fig. 88

INHALTSVERZEICHNIS

1	BEDIENTAFEL	55
1.1	Beschreibung	55
1.2	Allgemeine Beschreibung der Symbole	55
1.3	Navigationsbaum	56
1.4	Startbildschirmseite und Temperatureinstellung	57
2	VORBEREITENDE MASSNAHMEN	59
2.1	Einfüllen der Pellets	59
2.2	Stromversorgung	59
3	MENÜ EINSTELLUNGEN	60
3.1	Einstellungen	60
3.1.1	Einstellung "Zeit"	61
3.1.2	Einstellung "Datum"	61
3.1.3	Funktion "Brennstoff"	61
3.1.4	Funktion "Eco-Modus"	62
3.1.5	Funktion "Frostschutzmittel"	62
3.1.6	Display	63
3.1.7	Funktion "Reinigung"	64
3.1.8	Einstellung "Temp. Einheit"	64
3.1.9	Einstellung "Lautsprecher"	65
3.1.10	Funktion "Wartungszeit"	65
3.1.11	Installer menu	65
3.1.12	Service-Menü	66
3.1.13	Funktion "Bildschirmsperre"	66
3.1.14	Sprache	67
3.1.15	Informationen	67

4 VERWENDUNG	68
4.1 Zündung	68
4.1.1 Ändern der Lufttemperatur	69
4.1.2 Änderung der Leistung	69
4.2 Änderung der Parameter	69
4.3 Abschalten	70
4.4 Neuzündung nach einem Stromausfall	70
4.5 Betrieb mit externem Thermostat	71
4.6 Betrieb mit Umgebungssonde am Ofen	71
5 VERFÜGBARE FUNKTIONEN	72
5.1 Einstellung Timer	72
5.1.1 Aktivierung / Deaktivierung Timer	72
5.2 Statistiken	73
5.3 Tipps zum Betrieb	74
6 STÖRUNGEN UND MÖGLICHE ABHILFEN	75
6.1 Beschreibung der Alarme	75
6.2 Reset der Alarme	76
6.3 Beschreibung der Meldungen	77
6.4 Reset der Meldungen	77

IM HANDBUCH VERWENDETE SYMBOLIK UND IHRE BEDEUTUNG



Hinweis: Um besondere Informationen anzugeben.



Achtung: Um besonders wichtige und delikate Vorgänge anzugeben.



Gefahr: Um auf Handlungen hinzuweisen, die, wenn sie nicht korrekt ausgeführt werden, allgemeine Verletzungen verursachen oder zu Fehlfunktionen oder Sachschäden am Gerät führen können.

1 BEDIENTAFEL

1.1 Beschreibung

Das Bedienfeld besteht aus:

- 1) IR-Empfänger (Infrarot)
- 2) Sensor Umgebungslicht
- 3) Bildschirm Touchscreen
- 4) Lautsprecher
- 5) Anschluss RJ11



Abb. 1



Hinweis: Der Bildschirm ist vom Typ Touchscreen, d.h. es ist kein Druck erforderlich, um ihn zu aktivieren, sondern nur eine Berührung der Oberfläche.

1.2 Allgemeine Beschreibung der Symbole

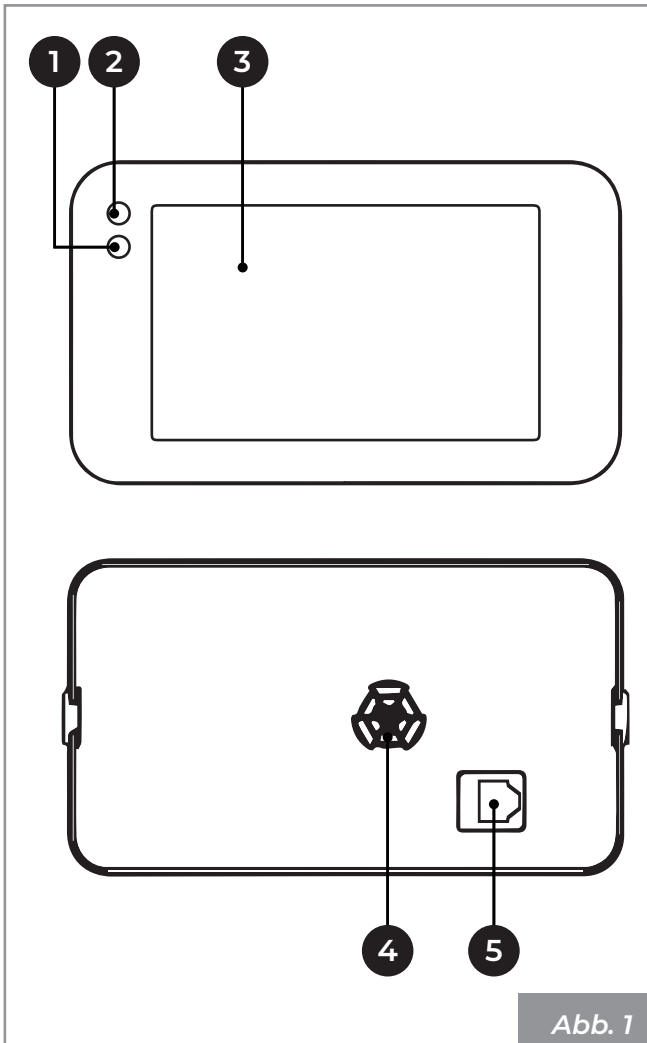

Abb. 2

Symbol	Beschreibung
	Alarm
	Meldung
	Funktion Eco-Modus aktiv
	Hauptmenü
	Zündung des Geräts
	Timer aktiviert
	Funktion "Frostschutzmittel" aktiv
	Bildschirmsperre
AUS	Angabe des abgeschalteten Geräts
20,0	Eingestellte Temperatur
25,8	Von der Sonde erfasste Temperatur

1.3 Navigationsbaum

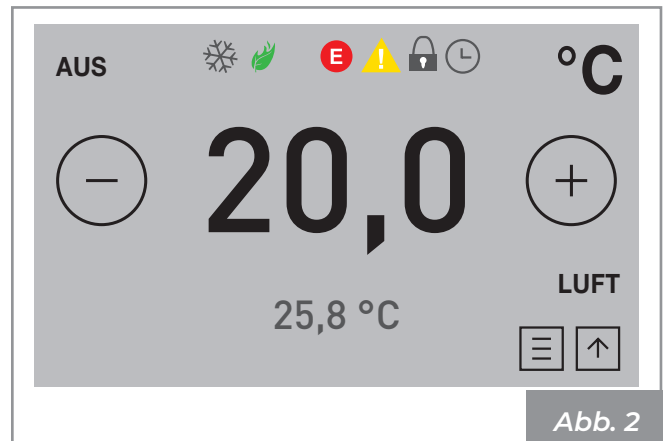

Abb. 3

1.4 Startbildschirmseite und Temperatureinstellung

Je nach Installationskonfiguration des Geräts werden unterschiedliche Startbildschirmseiten und unterschiedliche Temperaturwerte angezeigt.

Konfiguration 1 - Externer Thermostat

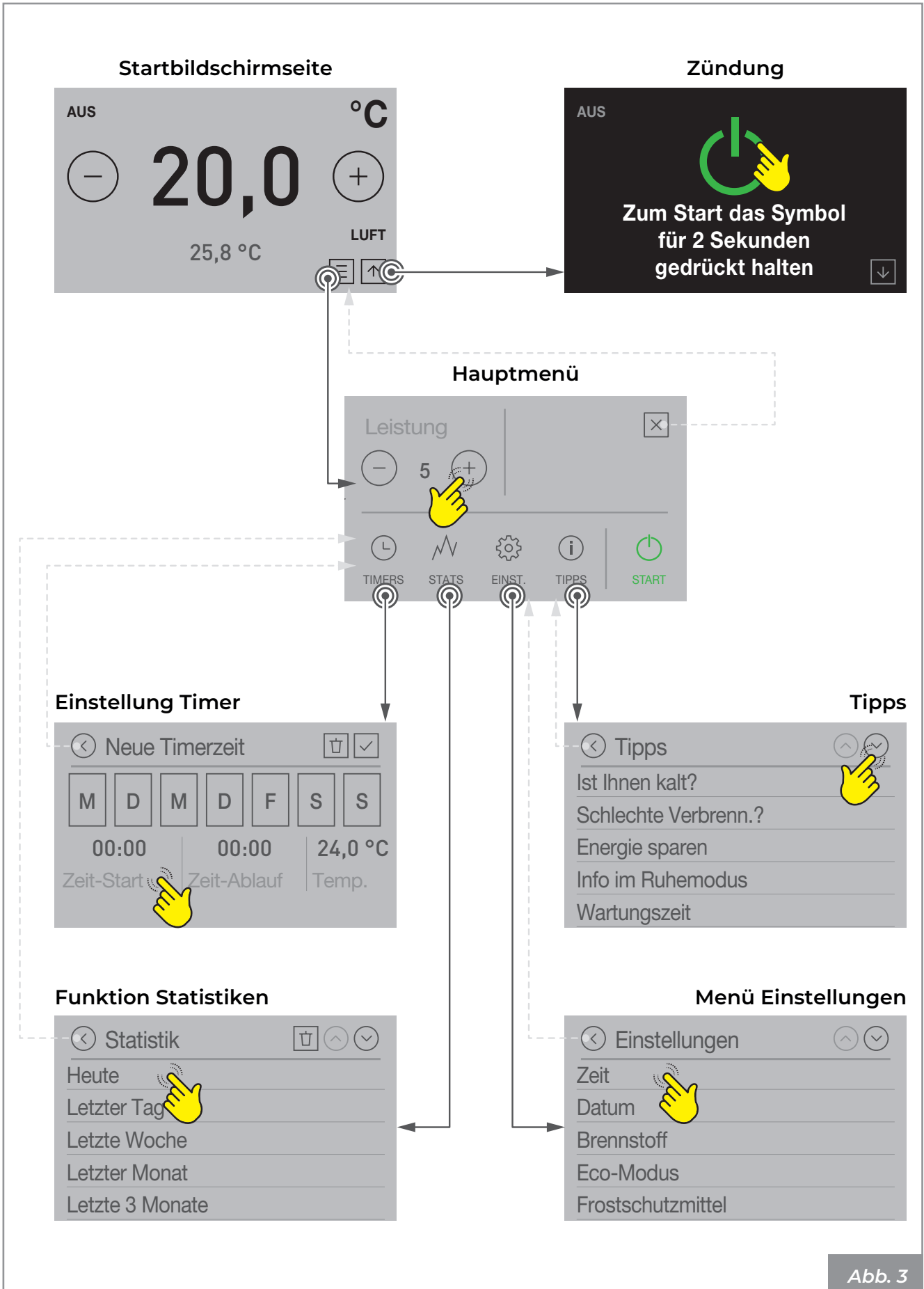
Startbildschirmseite



Abb. 4

Dieser Bildschirm zeigt die Vorlauftemperatur des Warmwassers des Kessels an.

Drücken Sie auf die Symbole ⊕ oder ⊖, um die gewünschte Vorlauftemperatur zu ändern (große Ziffern)

Die einstellbaren Werte liegen im Bereich von 45°C bis 80°C.

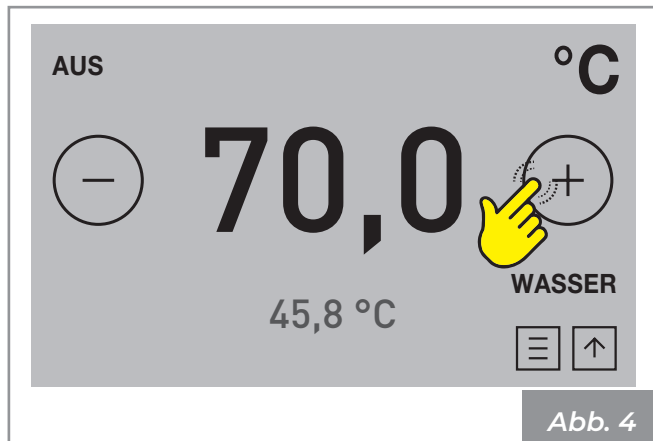
Die kleinen Ziffern zeigen die effektiv von der Vorlaufsonde erfasste Temperatur an

Drücken Sie auf "**WASSER**". Man geht auf die folgende Anzeige über:



Abb. 5

Drücken Sie auf "**Thermostat**", um zur vorhergehenden Bildschirmseite zurückzukehren.

Konfiguration 2 - Umgebungssonde

Startbildschirmseite

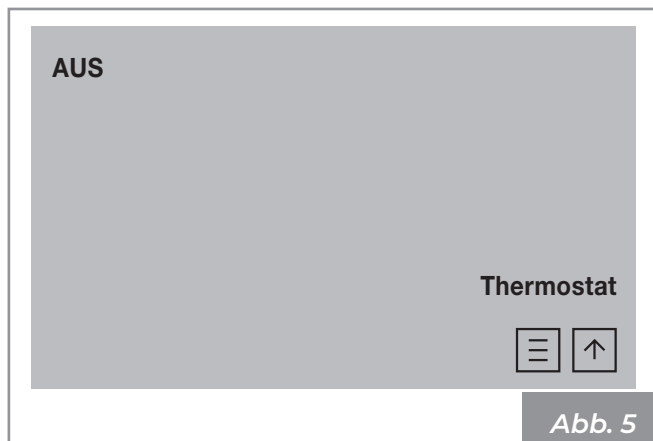

Abb. 6

Diese Bildschirmseite betrifft die Umgebungstemperatur.

Drücken Sie auf die Symbole ⊕ oder ⊖, um die Temperatur, die man im Raum zu erreichen wünscht, zu ändern (große Ziffern).

Die einstellbaren Werte liegen im Bereich von 10°C bis 40°C.

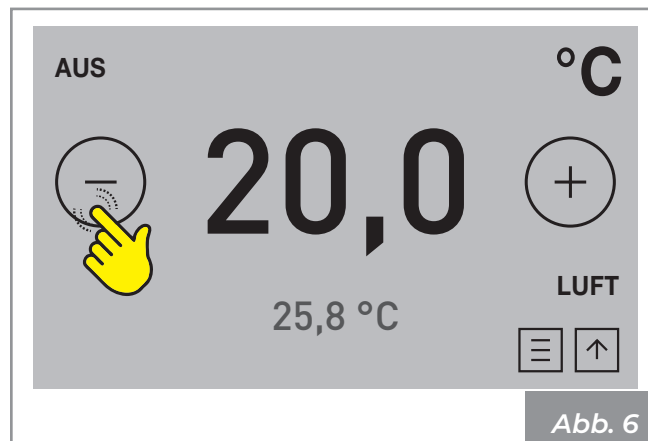
Die kleinen Ziffern visualisieren die von einer Sonde auf dem Gerät erfassten Umgebungstemperatur

Drücken Sie auf "**LUFT**". Man geht auf die Anzeige der Vorlauftemperatur des Warmwassers des Kessels über:



Abb. 7

Drücken Sie auf die Symbole ⊕ oder ⊖, um die gewünschte Vorlauftemperatur zu ändern (große Ziffern)

Die einstellbaren Werte liegen im Bereich von 45°C bis 80°C.

Die kleinen Ziffern zeigen die effektiv von der Vorlaufsonde erfasste Temperatur an

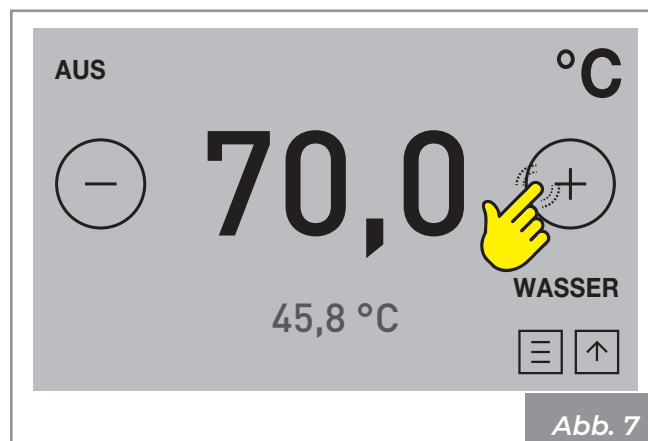
Konfiguration 3/4 - Coil accumulator/Non-coil accumulator

Startbildschirmseite

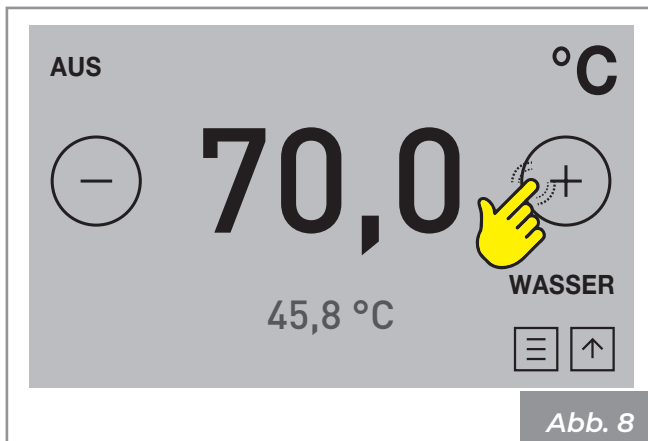

Diese Bildschirmseite betrifft die Temperatur des Warmwassers im Inneren des Speichers.

Drücken Sie auf die Symbole ⊕ oder ⊖, um die Temperatur, die man im Inneren des Speichers beizubehalten wünscht, zu ändern (große Ziffern). Die einstellbaren Werte liegen im Bereich von 45°C bis 80°C.

Die kleinen Ziffern visualisieren die effektiv von der Sonde im Speicher erfasste Temperatur.

2 VORBEREITENDE MASSNAHMEN

2.1 Einfüllen der Pellets

Der erste Vorgang, der vor dem Einschalten des Produkts ausgeführt werden muss, besteht darin, den Brennstoffbehälter (Pellets) vorzugsweise mit einer speziellen Schaufel zu füllen.

Entleeren Sie den Sack nicht direkt in den Behälter, um das Einfüllen von Sägemehl oder anderen Fremdkörpern zu vermeiden, die den ordnungsgemäßen Betrieb des Geräts beeinträchtigen könnten, und um ein Verstreuen der Pellets außerhalb des Behälters zu vermeiden.

Hinweis: Sicherstellen, dass der Deckel des Behälters ordnungsgemäß geschlossen ist, nachdem der Behälter mit Pellets befüllt wurde. Ein Sicherheitsschalter "SS" (nur bei Modellen, bei denen er vorgesehen ist) prüft, ob er korrekt geschlossen ist, und löst einen Alarm am Gerät aus, wenn der Deckel bei in Betrieb befindlichem Gerät länger als eine Minute offen bleibt.



Abb. 9

2.2 Stromversorgung

Schließen Sie das Gerät an die Stromversorgung an, stellen Sie den Zündschalter auf der Rückseite des Geräts auf "I".

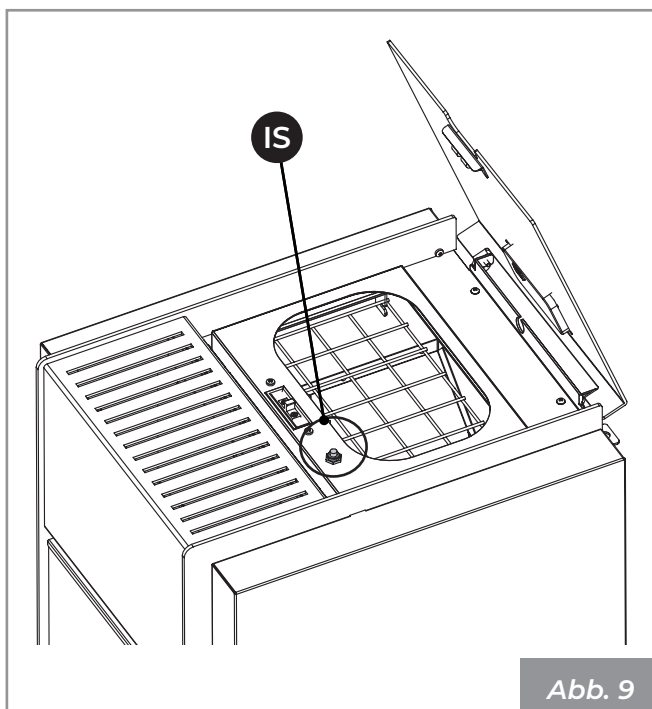

Abb. 10

Wenn der Anschluss korrekt ist, gibt das Gerät eine Reihe von intermittierenden Signaltönen ab und das Display schaltet sich ein.



Achtung: Bei längeren Stillstandszeiten wird empfohlen, den Schalter auf der Rückseite des Geräts auf AUS (O) zu stellen.



Hinweis: Stellen Sie sicher, dass Sie das Bedienfeld nicht berühren, wenn das Gerät mit Strom versorgt wird.

Durch das Speisen des Geräts wird das anfängliche Logo angezeigt.



Abb. 11

Nach einigen Sekunden erscheint die Startbildschirmseite:



Abb. 12

3 MENÜ EINSTELLUNGEN

3.1 Einstellungen

Drücken Sie auf das Symbol  zum Zugriff auf das Menü der Einstellungen.

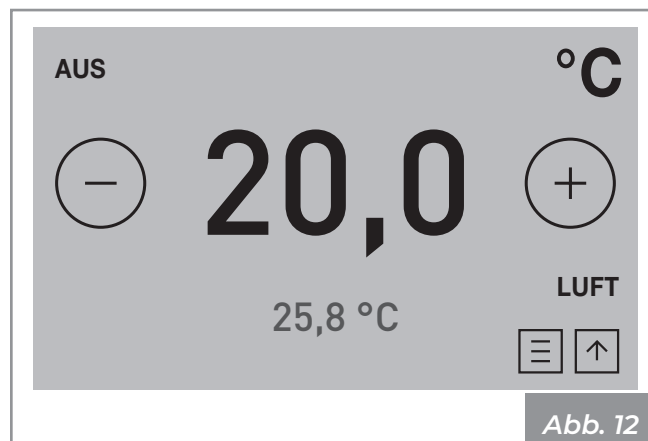





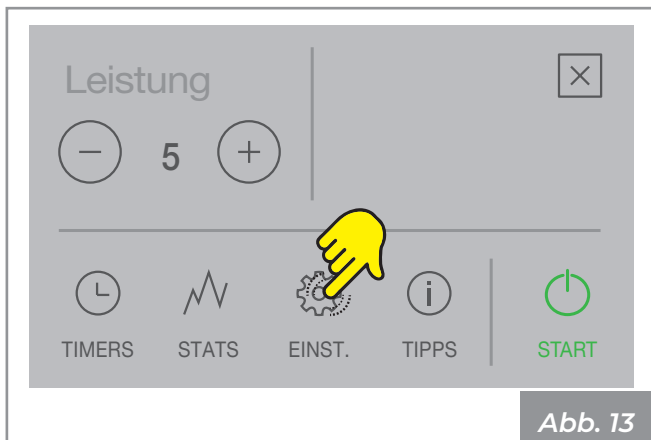

Abb. 13

Drücken Sie  und , um das Verzeichnis der Parameter zu scrollen.

Drücken Sie auf den gewünschten Parameter, um die Bildschirmseite zur Änderung des Parameters selbst zu öffnen.

Im Allgemeinen werden die Einstellungen des Parameters durch den Druck der Symbole  oder  geändert.

Drücken Sie , um zu bestätigen oder , um die Bildschirmseite zur Änderung zu schließen, ohne zu speichern.

Parameterverzeichnis

Parameter	Beschreibung	einstellbare Werte	Standardwerte
Zeit	Zeiteinstellung	Datum und Zeit korrekt eingestellt	
Datum	Datumseinstellung		
Brennstoff	Es ist möglich, 3 verschiedenen Brennstoffkonfigurationen einzustellen	1 ... 3	1
Eco-Modus *	Gibt den Eco-Modus frei	ON; AUS	<input type="checkbox"/> ON
Frostschutzmittel *	Mindesttemperatur, unter der das Gerät zündet	AUS; 3 ... 20 °C (AUS; 3 ... 50 °C)	AUS
Anzeigeoptionen	Stellt den Helligkeitsgrad und die Informationen der Bildschirmseite in Standby ein		
Temp. Einheit	Maßeinheit der Temperatur	°C ... °F	°C
Lautsprecher	Stellt die Lautstärke ein	AUS; 1 ... 5	2
Wartungszeit	Visualisiert die zur regelmäßigen Wartung fehlenden Stunden.		2016 h
Installer menu	Ändert/Visualisiert die Konfiguration des Geräts	PWD: „54“	
Service-Menü	Menü für den Kundendienst		
Bildschirmsperre	Einstellung der Tastensperre	AUS; LOW; HI	AUS
Sprache	Stellt die Sprache des Displays ein:	English Italiano Deutsch Español Français Português Bosanski jezik Slovenscina Swedish Dutch Romana	English
Info	Visualisiert die Systeminformationen		

(*) Parameter nur in einigen Konfigurationen verfügbar

3.1.1 Einstellung "Zeit"

Um die Uhrzeit einzustellen:



Abb. 14



Abb. 15

3.1.2 Einstellung "Datum"

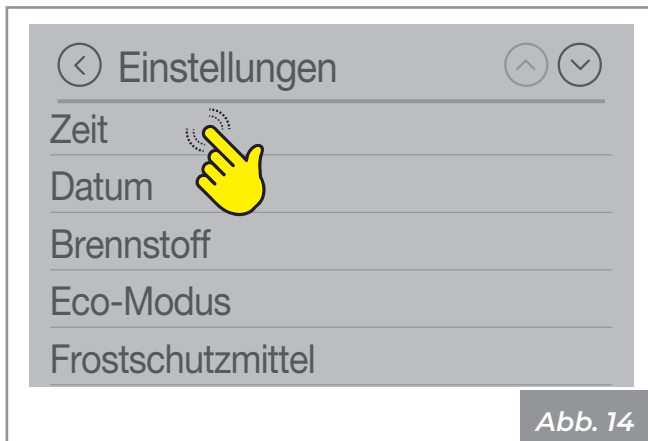
Um das Datum einzustellen:

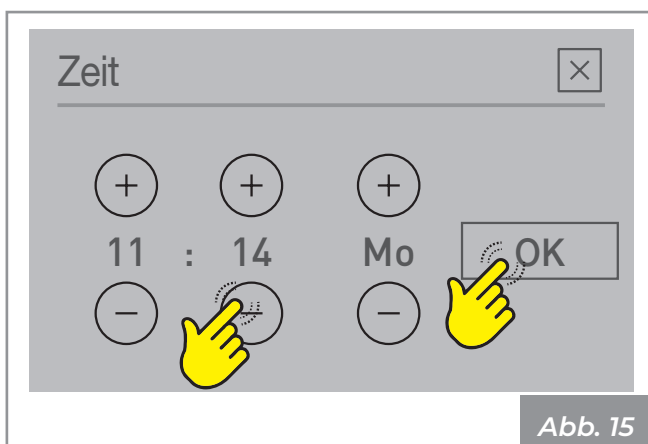

Abb. 16



Abb. 17

3.1.3 Funktion "Brennstoff"

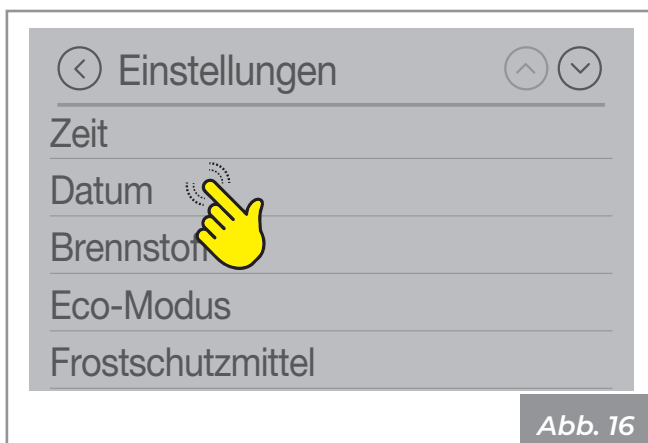
Die optimale Verbrennung hängt von mehreren Faktoren ab (Art der Installation, Betriebs- und Wartungsbedingungen, Art der Pellets usw.) Im Prinzip ist es ratsam, die Verbrennungskonfigurationen zu ändern (d.h. den Wert zu erhöhen), bis die zufriedenstellendste Lösung gefunden ist, wenn am Ende der Verbrennung in der Brennschale noch viele Rückstände vorhanden sind.

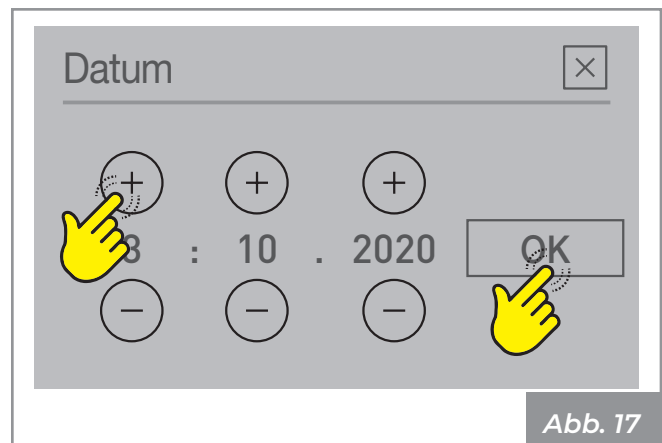

Abb. 18

Optimierung der Verbrennung:

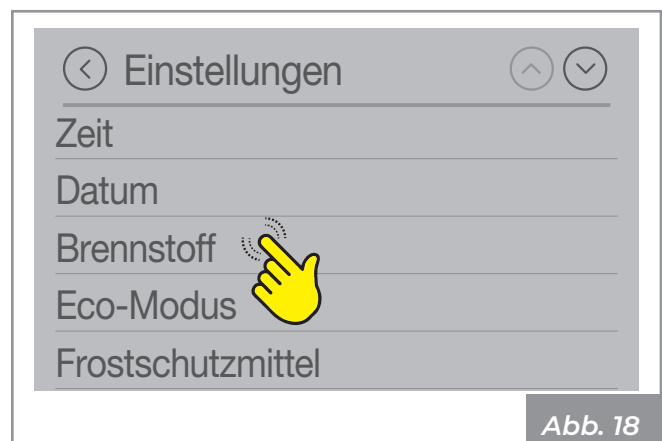

Abb. 19

Die einstellbaren Werte gehen von 1 bis 3.

- 1) Hohe Pelletgüte (En Plus)
- 2) Mittlere Pelletgüte
- 3) Geringe Pelletgüte

3.1.4 Funktion "Eco-Modus"

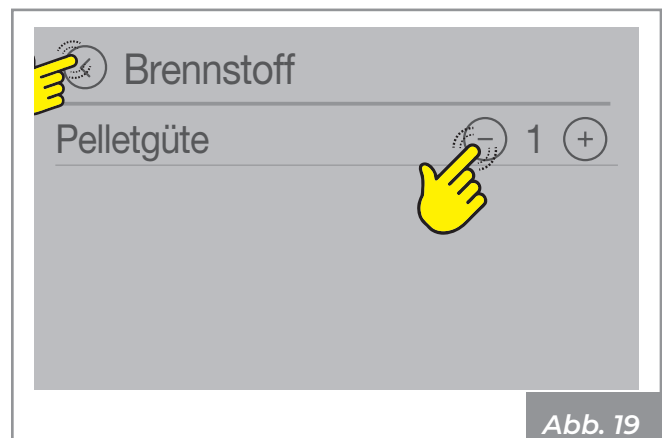
Nur in der Konfiguration 2 verfügbare Funktion.

Die Freigabe dieser Funktion bewirkt, dass sich das Gerät ausschaltet, wenn die gewünschte Lufttemperatur erreicht ist.

Wenn diese Funktion nicht freigegeben ist, moduliert das Gerät seinen Betrieb, indem es sich nicht ausschaltet.

Um diese Funktion zu aktivieren/deaktivieren:

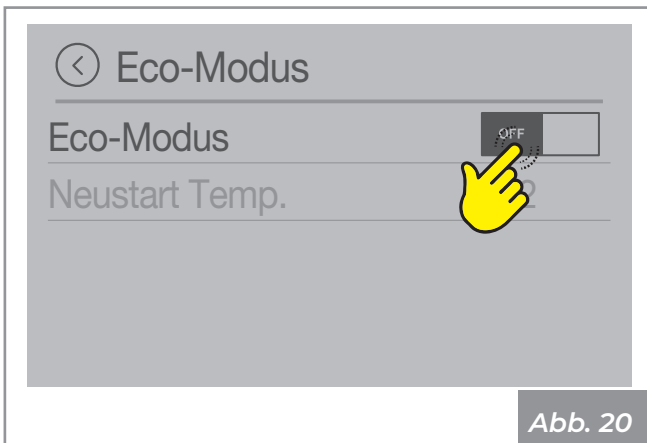

	Funktion "Eco-Modus" inaktiv
	Funktion "Eco-Modus" aktiv

Wenn man die Funktion "Eco-Modus" aktiviert, steht der "Neustart Temp." zur Verfügung, d.h. die Gradzahl unter der eingestellten Temperatur, ab der das Gerät automatisch wieder zündet.

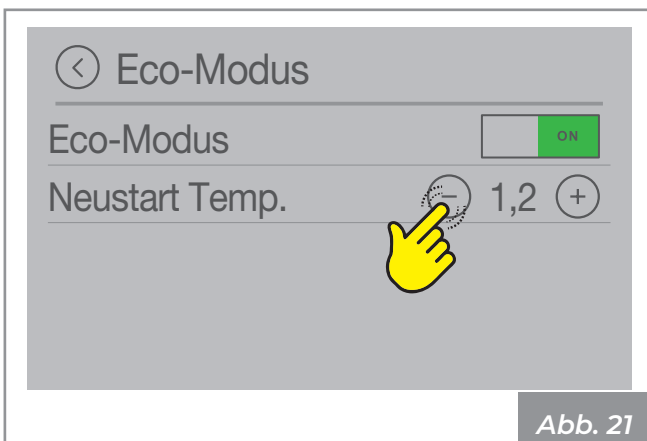

Beispiel: Wenn das Gerät so eingestellt ist, dass es sich bei 20°C abschaltet (Funktion "Eco-Modus" aktiv) und man einen "Neustart Temp." von 4°C einstellt, schaltet sich das Gerät wieder ein, wenn es eine Temperatur von weniger als oder gleich 16°C erfasst.

Die einstellbaren Werte gehen von 0,5 ... 5,0 °C.

3.1.5 Funktion "Frostschutzmittel"

Die Funktion ist nur bei den Konfigurationen 2, 3 und 4 verfügbar.

Es ist möglich, eine Mindesttemperatur einzustellen, unter der das Gerät sich einschaltet (außerhalb der eingestellten Zeiträume und nur, wenn der Timer aktiv ist).

Zur Änderung des Werts der Frostschutztemperatur:

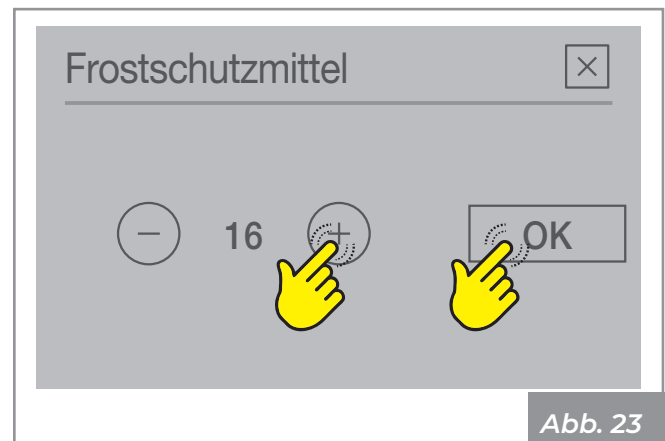
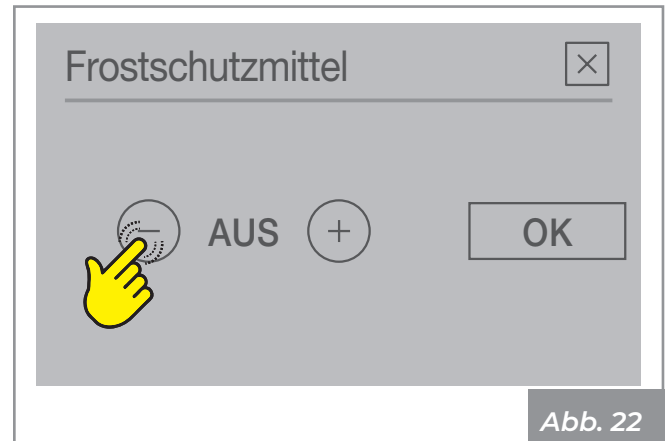

Die einstellbaren Werte:
 (AUS; 3 ... 20°C) für die Konfiguration 2
 (AUS; 3 ... 50°C) für die Konfigurationen 3 und 4

3.1.6 Display

Drücken Sie "Anzeigeeoptionen", um die Eigenschaften zur Visualisierung des Displays zu ändern.



Abb. 24

Helligkeitsgrad des Displays



Abb. 25

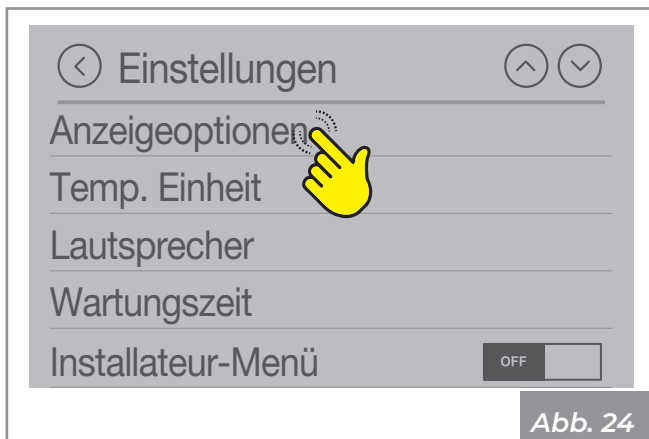

Abb. 26

Automatisch: Die Regulierung erfolgt in Abhängigkeit des Sensors der Helligkeit

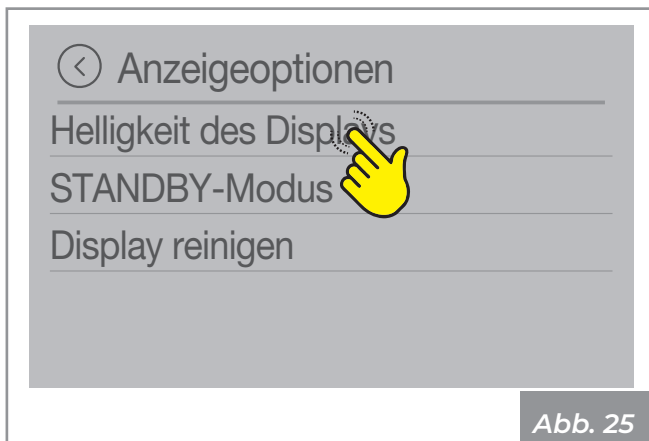

Abb. 27

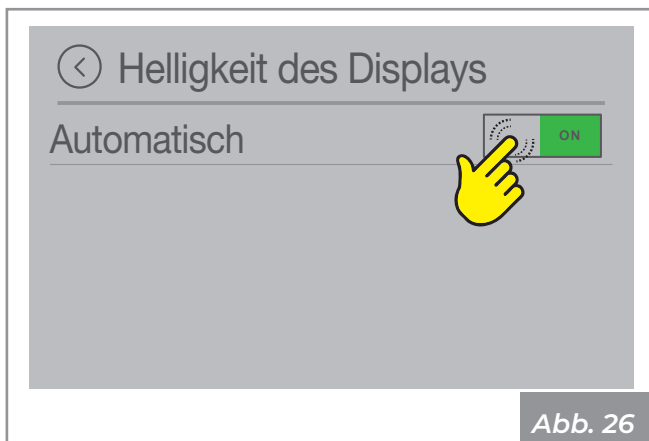
Helligkeit während der Verwendung des Displays: von 0 bis 100% Helligkeit

Die einstellbaren Werte: MIN - 2 - 3 - 4 - MAX;

Helligkeit des Displays beim Übergang in Standby: von 0 bis 50% Helligkeit

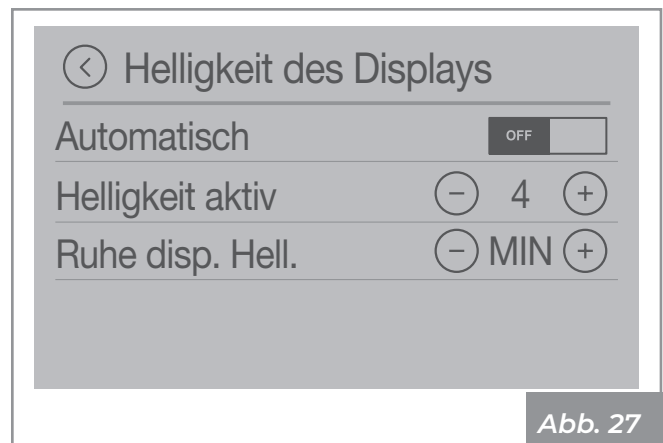
• AUS

• MIN - 2 - 3 - 4 - MAX

In Position AUS wird das Display nach 60 Sekunden der Nichtbenutzung schwarz, es wird durch seine Berührung aktiviert.

Display in "Standby Modus"



Abb. 28



Abb. 29

Man kann wählen, was angezeigt werden soll, wenn der Bildschirm sich in Standby befindet:

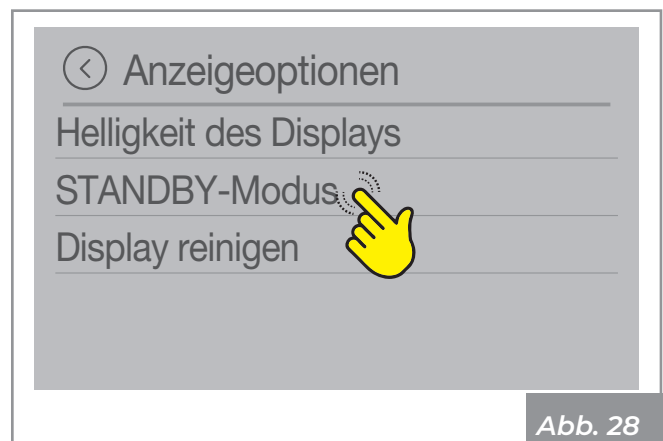
- Logo
- Zeit
- Lufttemperatur
- Wassertemperatur

Beispiel von Bildschirmseiten, die sich zyklisch abwechseln, wenn der Bildschirm sich in Stand-by befindet:

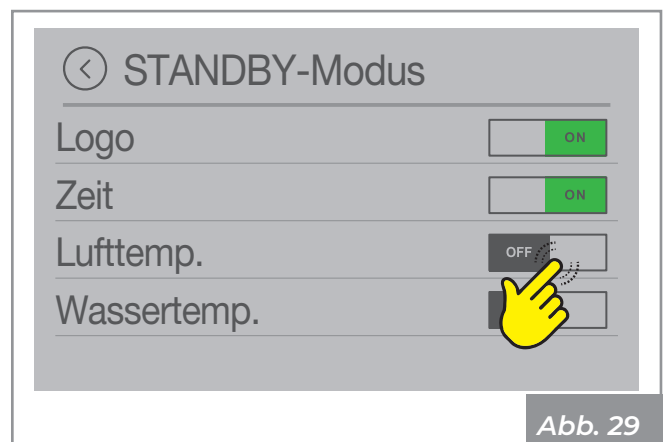
Uhrzeit und Datum



Abb. 30

Lufttemperatur

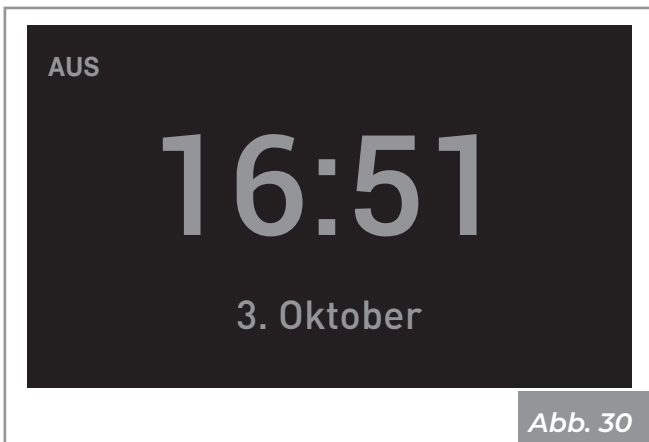

Abb. 31

3.1.7 Funktion "Reinigung"

Einstellung zur Ausführung der Reinigung des Bildschirms

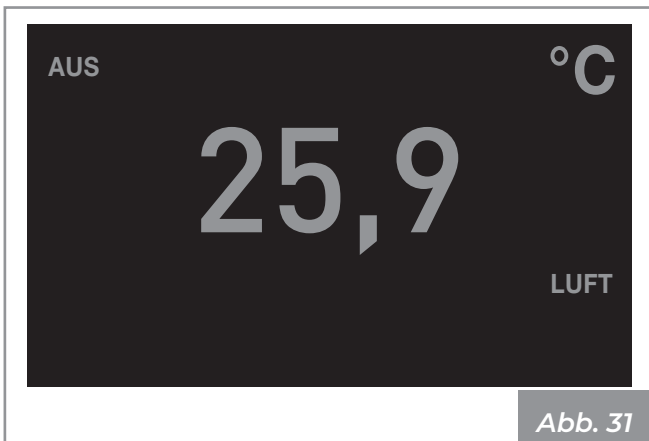

Abb. 32

Drücken Sie "START": Ein Countdown beginnt; der Signalton BIP zeigt an, dass der Bildschirm inaktiv ist, und man kann mit der Reinigung fortfahren, ohne seine Funktionalität zu beeinträchtigen. Am Ende des Countdowns wird der Touchscreen

wieder aktiv.

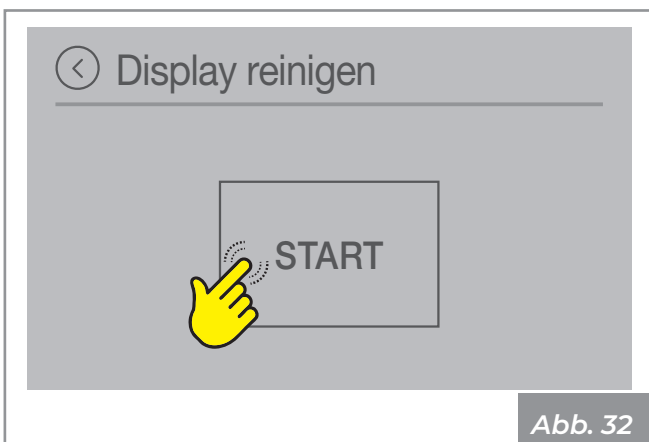

Abb. 33

3.1.8 Einstellung "Temp. Einheit"

Um die Maßeinheit der Temperatur zu ändern:

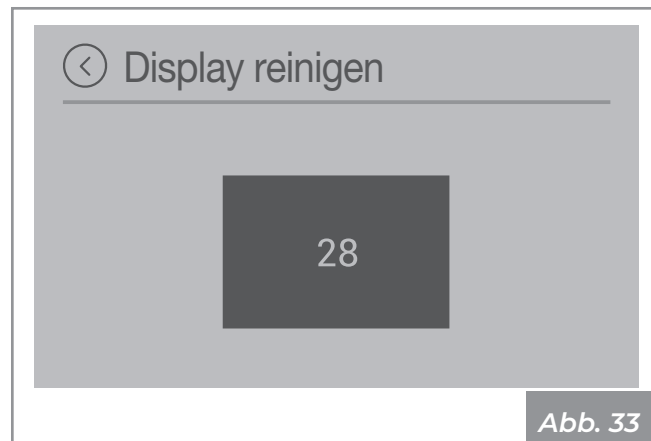

Abb. 34

Um von °C auf °F zu ändern, auf ⊕ oder ⊖ drücken. Drücken Sie , um zu bestätigen.

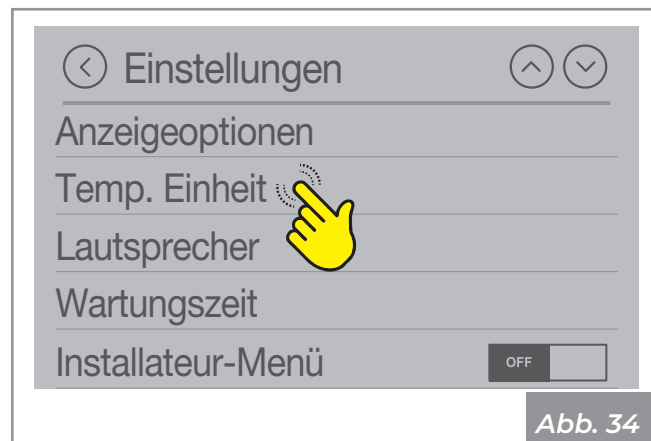

Abb. 35

3.1.9 Einstellung "Lautsprecher"

Um den Intensitätsgrad des Lautsprechers zu ändern:

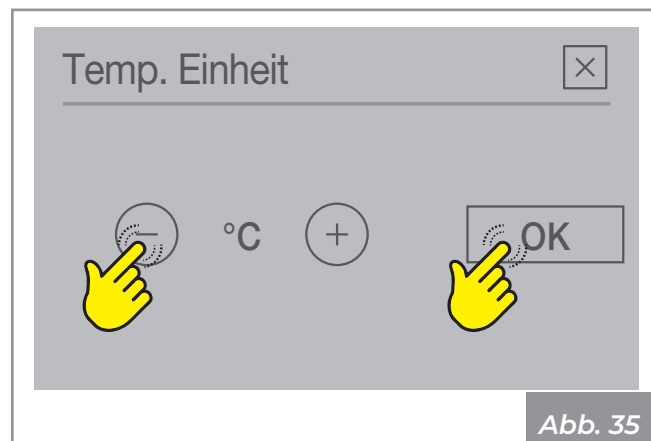

Abb. 36

Drücken Sie auf ⊕ und ⊖, um die gewünschte Lautstärke einzustellen (AUS, 1 ... 5).
Drücken Sie **OK**, um zu bestätigen.

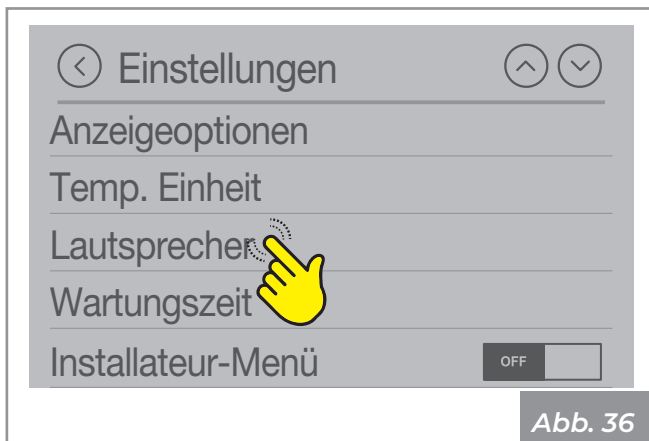

Abb. 37

3.1.10 Funktion "Wartungszeit"

Gibt an, wie viel Zeit bis zur nächsten regelmäßigen Wartung fehlt.



Abb. 38

Visualisiert die zur regelmäßigen Wartung fehlenden

Stunden.

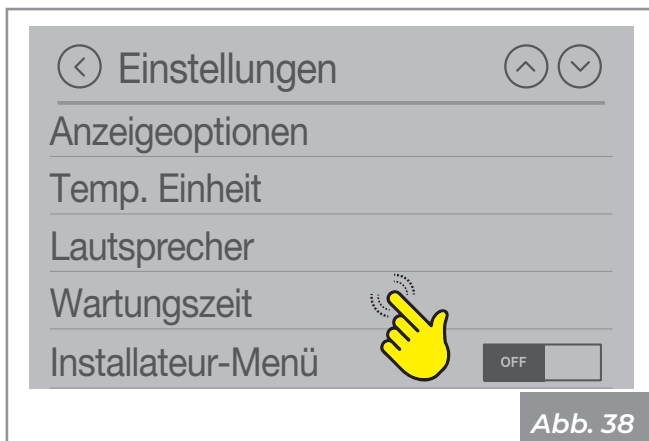

Abb. 39

3.1.11 Installer menu



Gefahr: Die Untermenüs sind durch Passwort geschützt und ausschließlich der Verwendung von Seiten des technischen Kundendienstes vorbehalten.



Abb. 40

Drücken Sie auf **ON**: Es erscheint das Passwort, **54** einstellen und **OK** zur Bestätigung drücken.

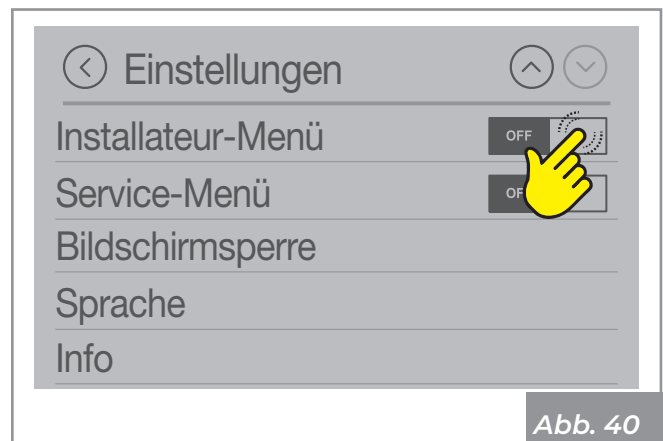

Abb. 41

Drücken Sie auf "Konfigurationen".

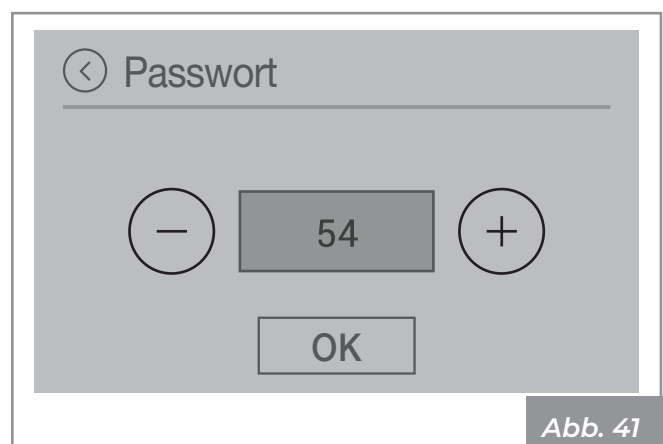

Abb. 42

Es werden die möglichen Konfigurationen des Geräts visualisiert. Die derzeitig eingestellte Konfiguration ist auf ON eingestellt, alle anderen auf AUS.

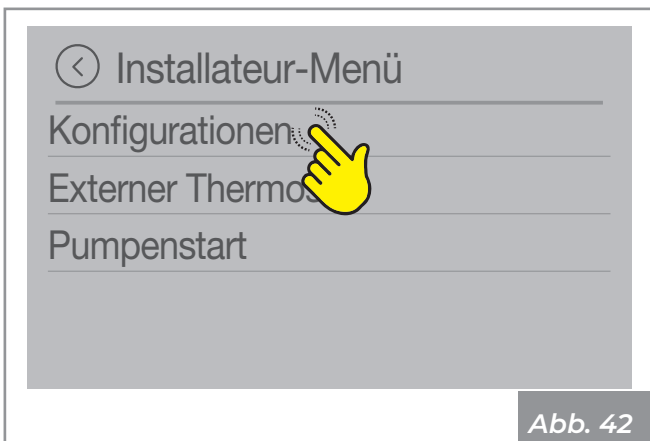

Abb. 43

Konfiguration	Beschreibung	Standard
1	Externer Thermostat	OFF
2	Umgebungssonde	ON
3	Coil accumulator	OFF
4	Non-coil accumulator	OFF

Nehmen Sie auf die Anlagenkonfiguration im Installationshandbuch Bezug.

3.1.12 Service-Menü

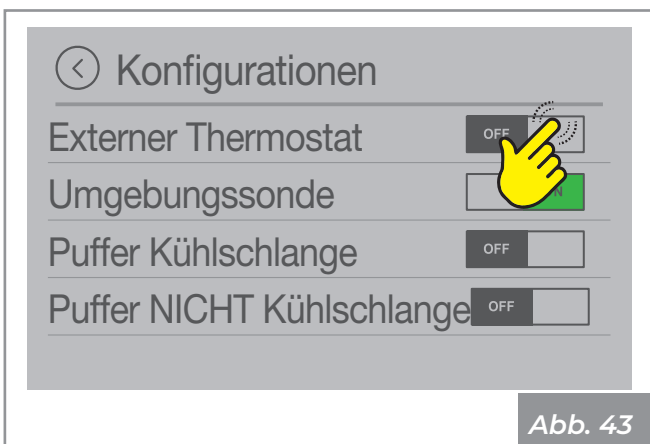

Gefahr: Die Untermenüs sind durch Passwort geschützt und ausschließlich der Verwendung von Seiten des technischen Kundendienstes vorbehalten.



Abb. 44

3.1.13 Funktion "Bildschirm Sperre"

Um den Zugriff auf die Funktionalitäten des Displays zu blockieren:

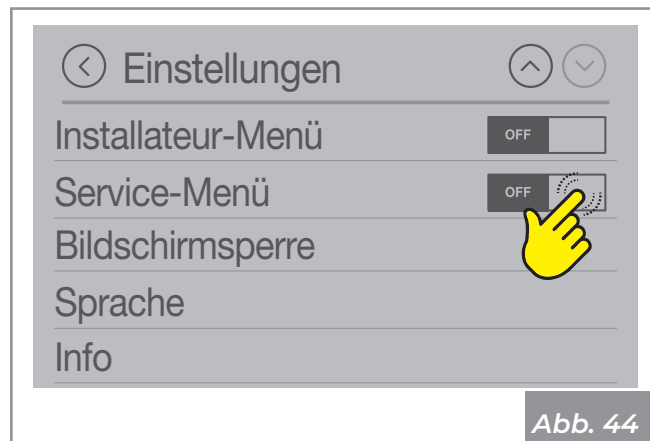

Abb. 45

- **AUS** : Bildschirm Sperre deaktiviert
- **LOW** : Partielle Bildschirm Sperre
- **HI** : Bildschirm Sperre aktiviert

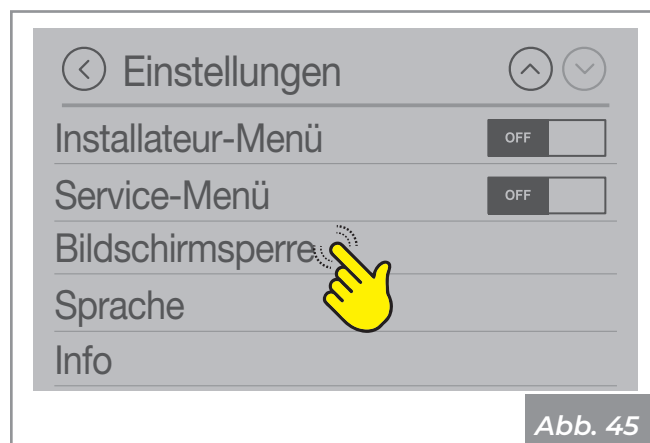

Abb. 46

Um die Funktion zu deaktivieren, den Zugriff auf "Bildschirm Sperre" vornehmen und **AUS** einstellen.

3.1.14 Sprache

Um die Sprache einzustellen:

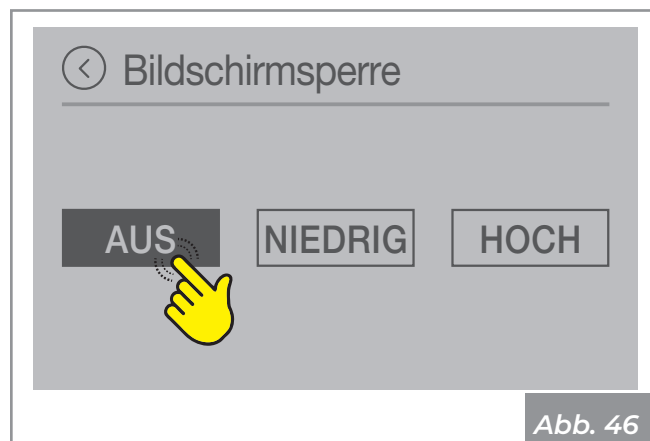

Abb. 47

3.1.15 Informationen

Um die Systeminformationen zu visualisieren:



Abb. 51



Abb. 48

Zeigt die aktuelle Softwareversion an.

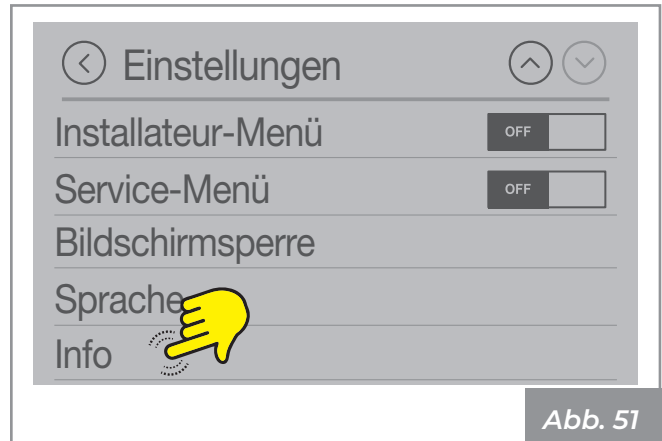

Abb. 52



Abb. 49

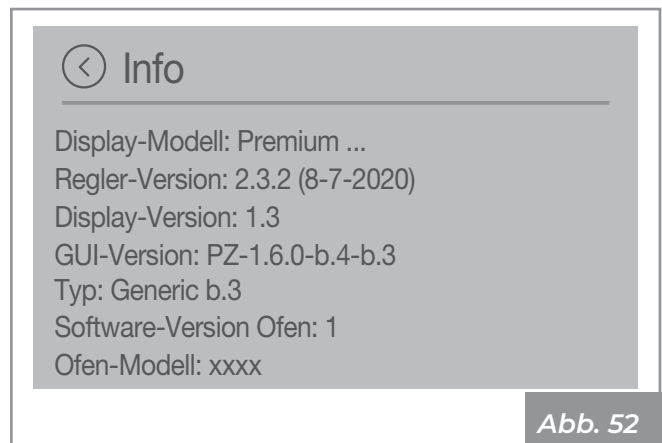

Abb. 50

4 VERWENDUNG

4.1 Zündung



Gefahr: Vor jeder Zündung sicherstellen, dass die Brennschale vollkommen leer und korrekt in ihrer Aufnahme positioniert ist.

Es bestehen zwei Modalitäten zum Start des Geräts.

Erste Modalität:

Drücken Sie das Symbol 



Abb. 53

Halten Sie das Symbol für zwei Sekunden gedrückt, um das Produkt zu starten.

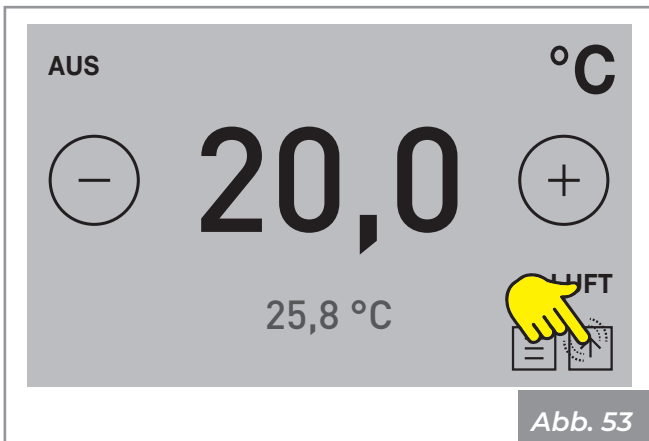

Abb. 54

Zweite Modalität:

Nehmen Sie den Zugriff auf das Hauptmenü vor und halten Sie START für einige Sekunden gedrückt.

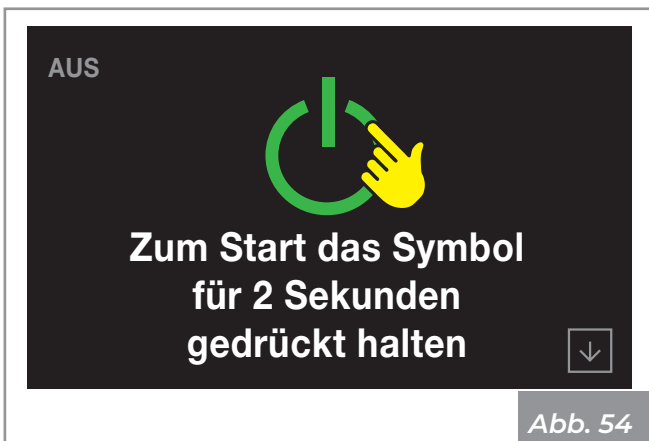

Abb. 55

An diesem Punkt beginnt das Gerät die Phase der Zündung.

Es wird diese Sequenz angezeigt:

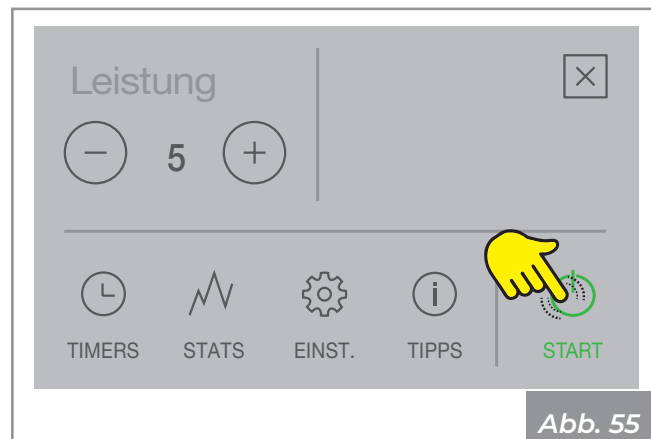

Abb. 56



Abb. 57

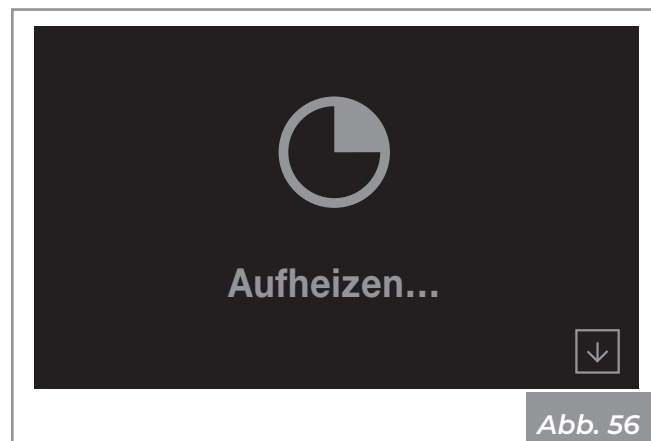

Abb. 58

Nach einigen Sekunden erscheint die Startbildschirmseite:

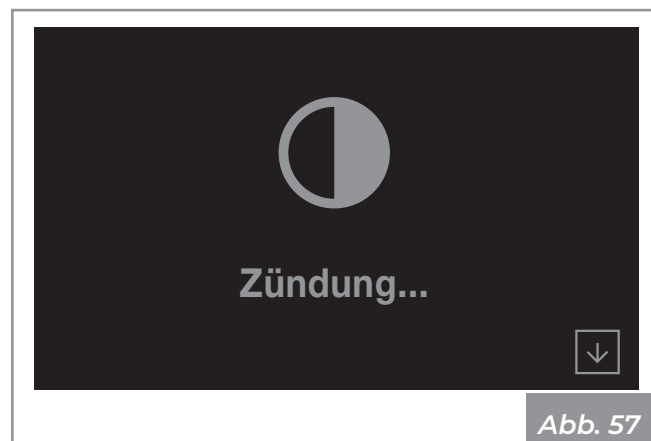

Abb. 59

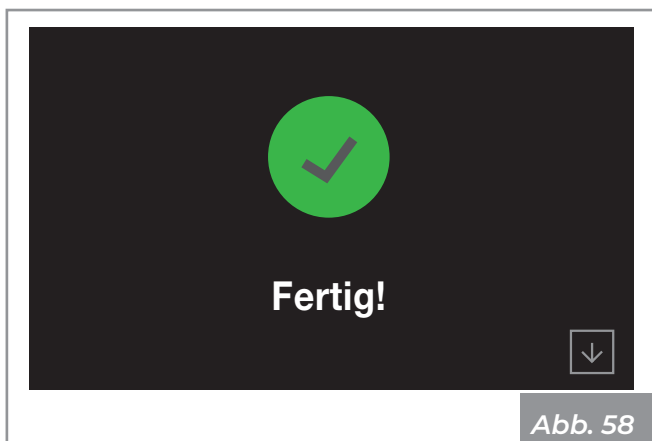

Achtung: Automatische Zündung: Das Gerät besitzt eine automatische Vorrichtung, die die Zündung des Pellets ohne die Verwendung von anderen herkömmlichen Zündern erlaubt.

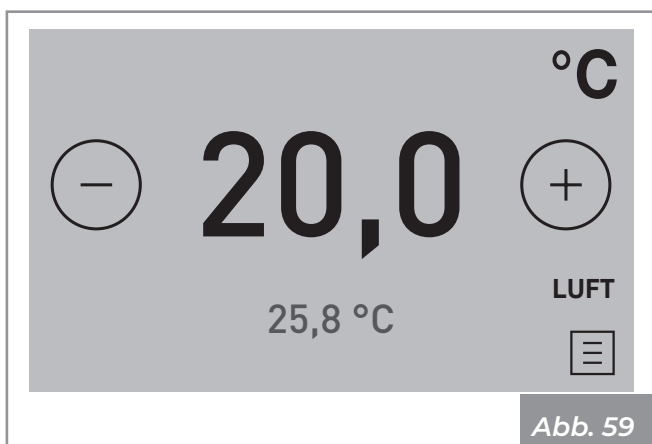

Gefahr: Vermeiden Sie die manuelle Zündung des Geräts, wenn das System zur automatischen Zündung beeinträchtigt ist.



Achtung: Während der ersten Zündung des Geräts können sich unangenehme Gerüche oder Rauchgase bilden, die durch die Verdampfung oder die Trocknung einiger verwendeten Materialien verursacht werden. Diese Erscheinung verschwindet mit der Zeit. Es wird empfohlen, die Räume gut zu lüften, wenn der Ofen die ersten Male angezündet wird.

Geräte der Produktreihe "Ermetica":

Vermeiden Sie es bei jedem Öffnen der Feuerraumtür, diese über einen längeren Zeitraum offen zu lassen, um zu verhindern, dass der Schließsensor den Status der offenen Tür durch einen akustischen Alarm meldet.

4.1.1 Ändern der Lufttemperatur

Durch die Änderung dieses Wertes wird die Temperatur, die man im Raum zu erreichen wünscht, festgelegt, die direkt von einer auf dem Gerät angebrachten Sonde abgelesen wird.



Abb. 60

Um den Wert der Temperatur zu ändern, auf die Symbole ⊕ oder ⊖ drücken:

Die einstellbaren Werte liegen im Bereich von 10°C bis 40°C.

4.1.2 Änderung der Leistung

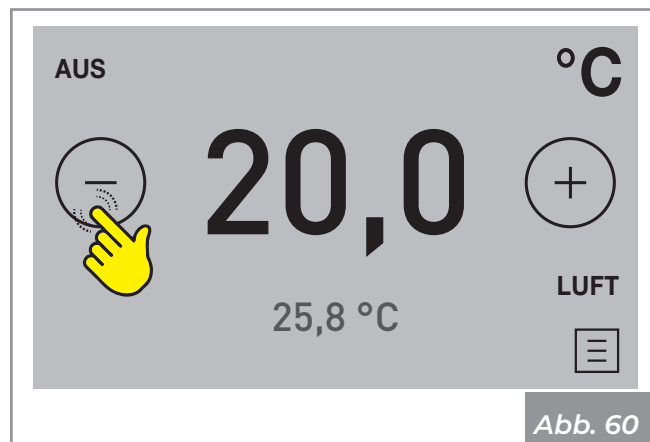
Die Leistung definiert die vom Gerät erzeugte Wärmemenge und wirkt sich daher auch direkt auf den Verbrauch aus.



Abb. 61

Um den Wert der Leistung zu ändern, auf die Symbole ⊕ oder ⊖ drücken:

Die einstellbaren Werte gehen von 1 (Minimum) bis 5 (Maximum).

4.2 Änderung der Parameter

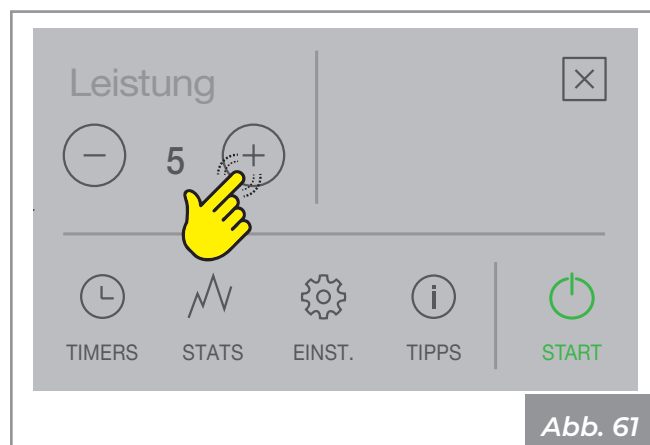
Es besteht die Möglichkeit der Änderung der Betriebsparameter gemäß den Angaben im Kapitel "3 Menü Einstellungen"



Hinweis: Die eingestellten Werte werden bis zur nachfolgenden Änderung beibehalten, auch bei abgeschaltetem oder von der Stromversorgung abgetrenntem Gerät.

4.3 Abschalten

Um das Gerät abzuschalten, die Taste STOPP für einige Sekunden gedrückt halten;



Abb. 62



Abb. 63

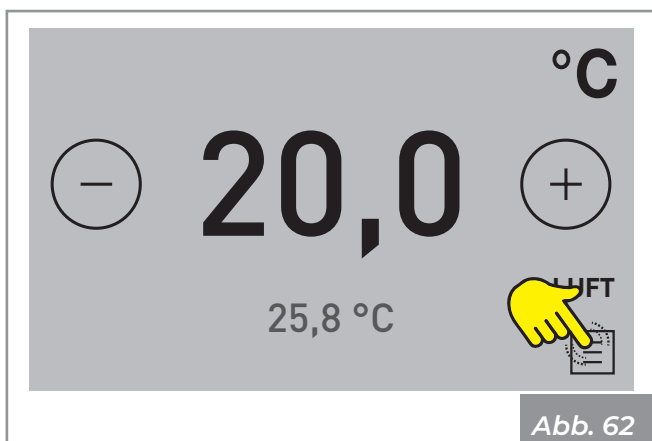

Abb. 64

Wenn die Temperatur sich noch als hoch erweist, wird eine Phase der Abkühlung gestartet:

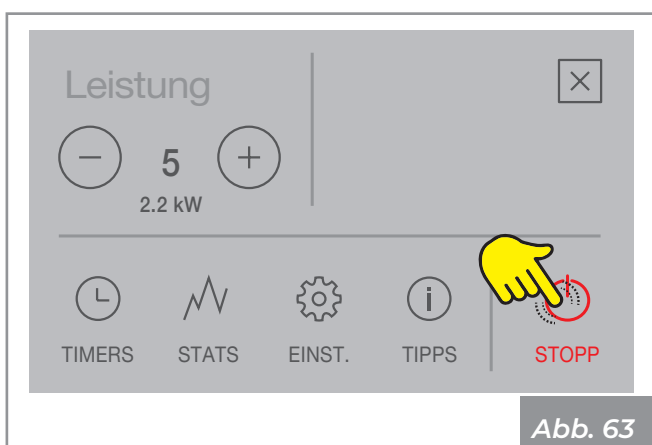

Abb. 65

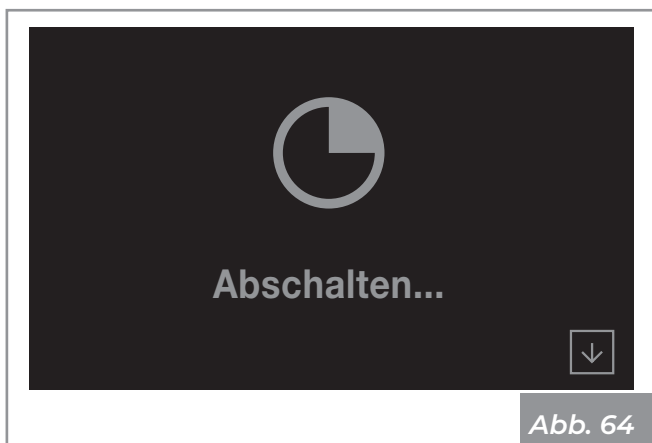

Hinweis: Um eine Neuzündung auszuführen, wird empfohlen, zu warten, bis das Gerät vollkommen abgekühlt ist.

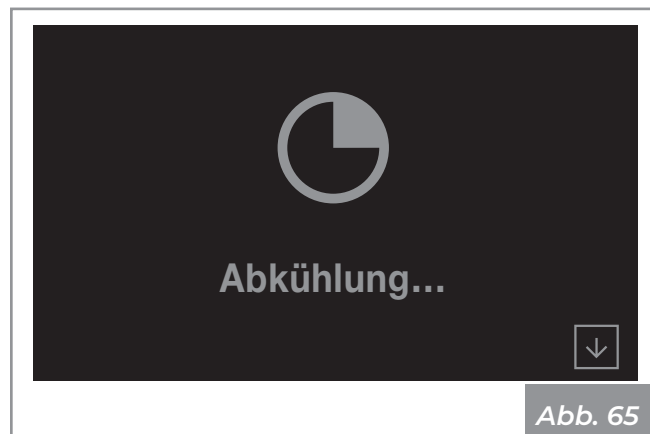

Gefahr: Man empfiehlt, das Gerät unter genauer Befolgung der oberen Angaben abzuschalten. Es ist verboten, das Gerät durch Abtrennen der Stromversorgung abzuschalten.

4.4 Neuzündung nach einem Stromausfall

Im Falle einer Stromunterbrechung zündet das Gerät automatisch wieder, indem es die Sicherheitsbedingungen prüft, sobald die Stromversorgung wieder hergestellt ist.

4.5 Betrieb mit externem Thermostat

Wenn das Gerät über ein externes Thermostat (oder Thermostat mit Zeitschaltuhr) gesteuert wird, muss der Installateur die **Konfiguration 1** eingestellt haben.

In diesem Fall schaltet das Gerät ab, wenn für das externe Thermostat die Bedingungen erfüllt sind (offener Kreislauf).

Das Gerät zündet automatisch wieder, wenn die Temperatur unter den auf dem externen Thermostat eingestellten Wert sinkt (geschlossener Kreislauf).



Hinweis: Bei der ersten Zündung, oder falls das Abschalten direkt durch das Gerät erfolgte, muss das Gerät direkt über die Bedientafel gezündet werden.

4.6 Betrieb mit Umgebungssonde am Ofen

Das Gerät kann manuell oder programmiert gezündet/abgeschaltet werden.

Das Gerät moduliert die Leistung entsprechend der von der Sonde gemessenen Umgebungstemperatur (es versucht, die gewünschte Temperatur bei möglichst geringem Verbrauch aufrechtzuerhalten).

Im Falle, dass der Benutzer die Funktion "Eco-Modus" freigegeben hat, schaltet das Gerät, statt zu modulieren, beim Erreichen der eingestellten Temperatur ab und zündet erneut, wenn die Lufttemperatur unter das eingestellte Delta sinkt (siehe Abschnitt "3.1.4 Funktion "Eco-Modus"").



Abb. 66

5 VERFÜGBARE FUNKTIONEN

5.1 Einstellung Timer

Es ist möglich, die benutzerdefinierten Programme für das automatische Zünden und/oder Abschalten des Geräts einzustellen, zu aktivieren und den verschiedenen Wochentagen zuzuordnen.

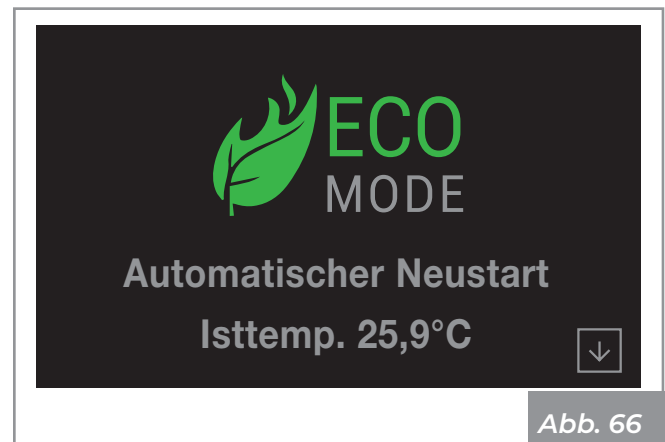
Es können bis zu sechs benutzerdefinierte Programme konfiguriert werden.

Für jedes Programm können eingestellt werden: Zündzeitpunkt, Ausschaltzeitpunkt und gewünschte Temperatur.

Jedem Wochentag können bis zu drei Programme zugeordnet werden.

Beispiel von eingestelltem Timer



Abb. 70



Abb. 67

Hinweis: Die Temperatur, die am Timer eingestellt werden kann, hängt von der Art der Anlagenkonfiguration ab. Für weitere Details siehe Abschnitt "1.4 Startbildschirmseite und Temperatureinstellung".

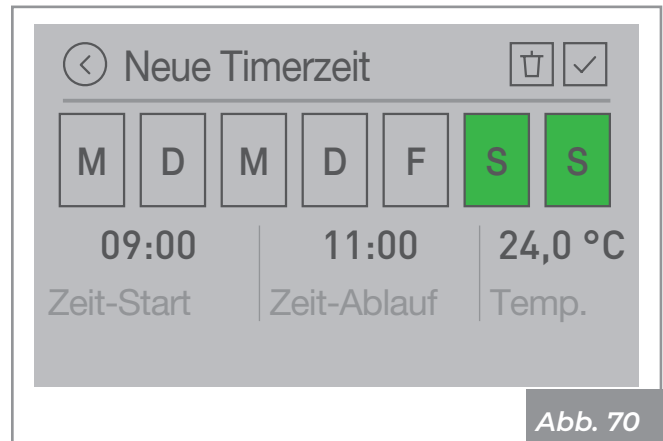

5.1.1 Aktivierung / Deaktivierung Timer

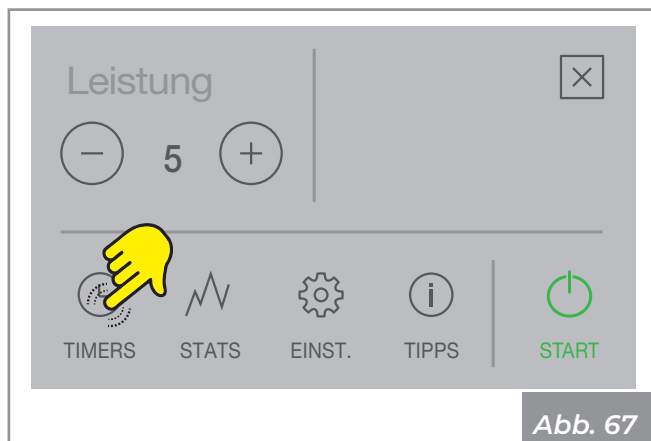
Wählen Sie ON, um den Timer freizugeben, oder AUS, um ihn zu sperren.



Abb. 68



Abb. 71

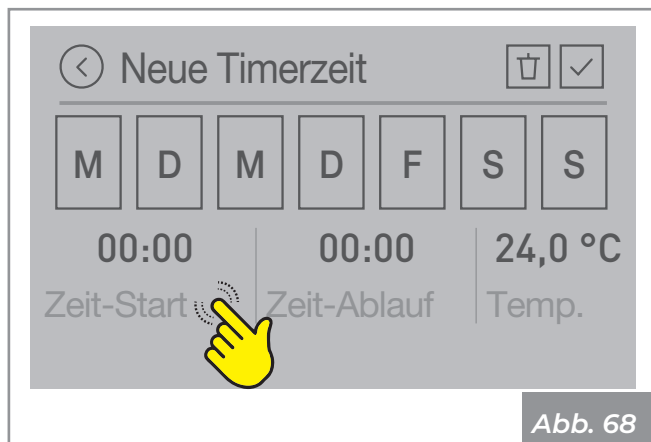

Abb. 69

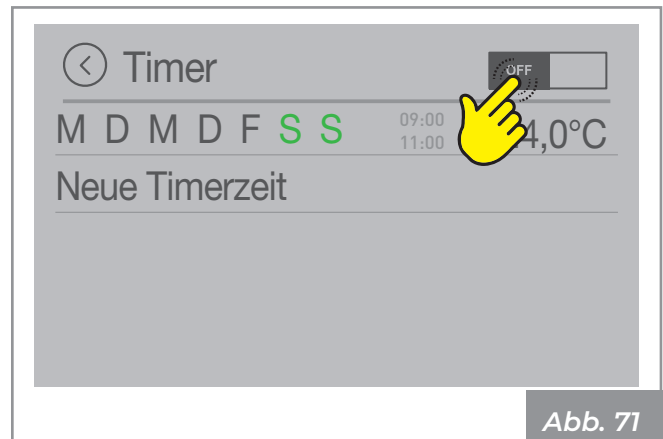

Abb. 72

Das Gerät wird um 9:00 Uhr zünden und samstags und sonntags um 11:00 abschalten

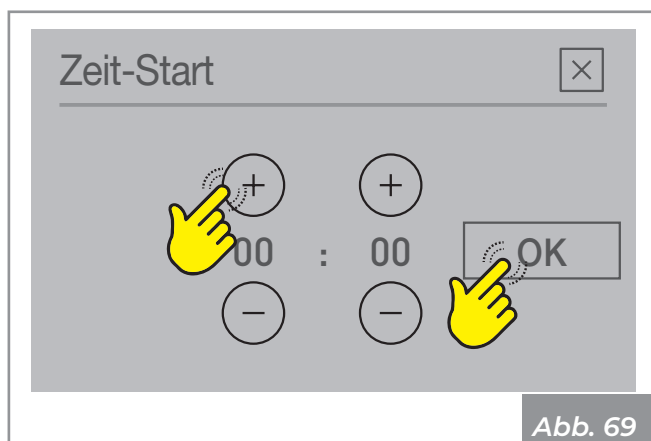
5.2 Statistiken

Es ist möglich, die Verbrauchsstatistiken des Geräts zu visualisieren.

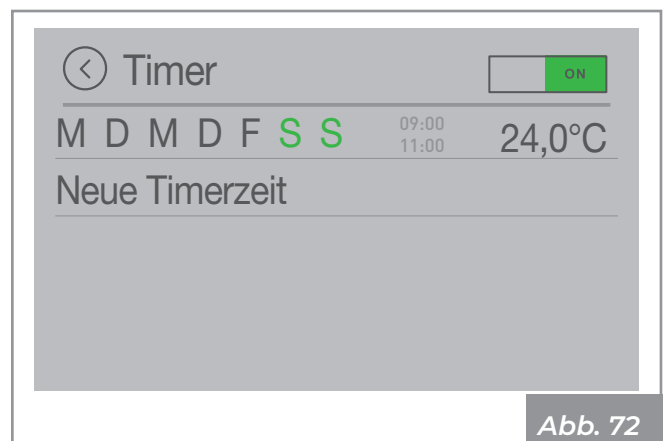

Abb. 73



Abb. 74

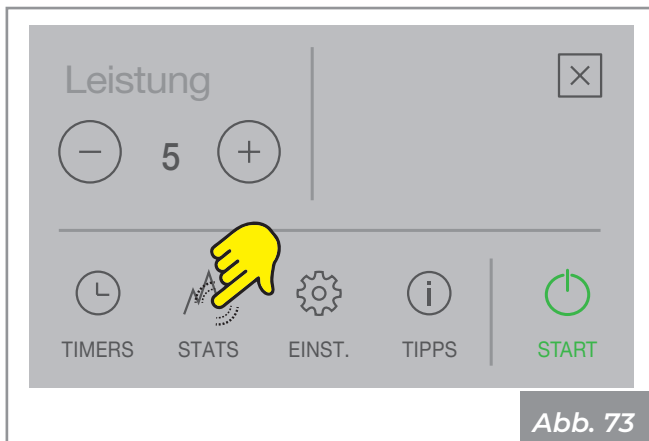

Abb. 75

Beispiel von Statistik

Durch die Wahl von "Heute" kann Folgendes angezeigt werden:

- die Kilogramme von verwendeten Pellets
- die Zündzeit
- die durchschnittlich erzeugte Leistung
- die durchschnittliche Lufttemperatur

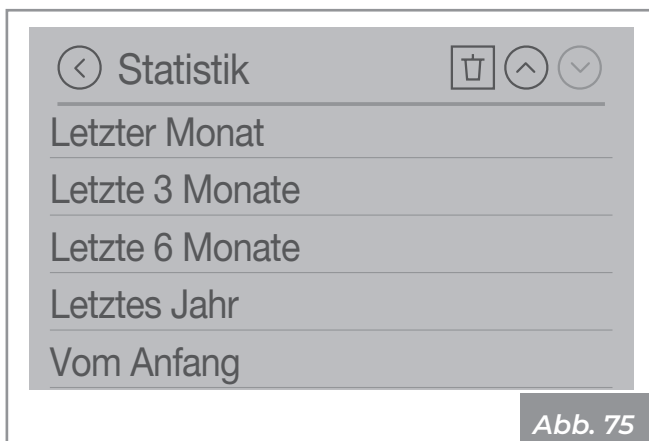
Heute	
Ges. Verbrauch	0 kg
Aufwärmzeit	0:00
Dschn. Leistung	0.0 kW
Dschn. Temp.	25,7 °C

Abb. 76

Statistik löschen

Drücken Sie das Symbol , um die Statistiken zu löschen:



Abb. 77



Abb. 78

5.3 Tipps zum Betrieb

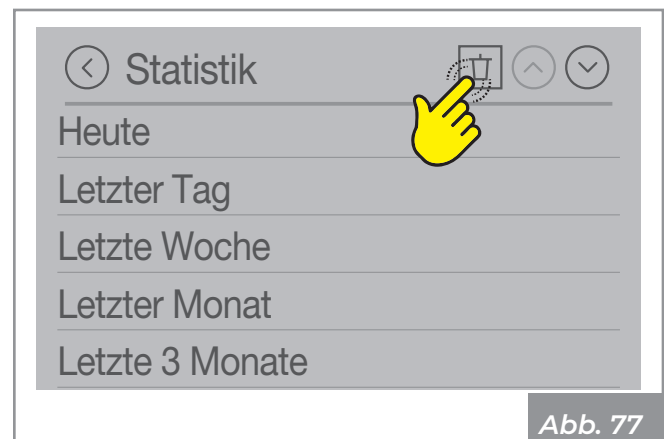
Dieses Menü wird verwendet, um einfache Ratschläge zur guten Funktionsweise des Produkts zu geben.

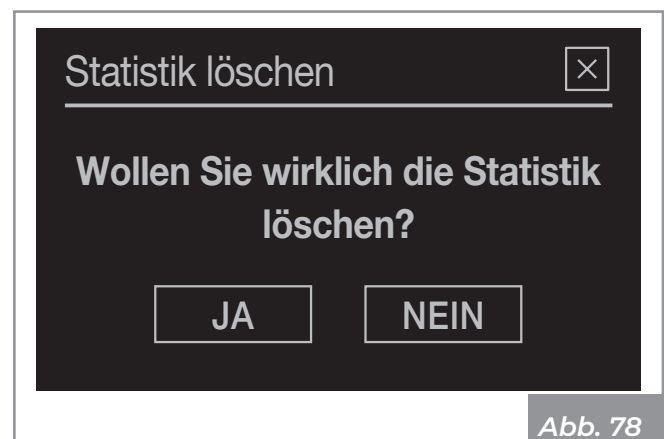
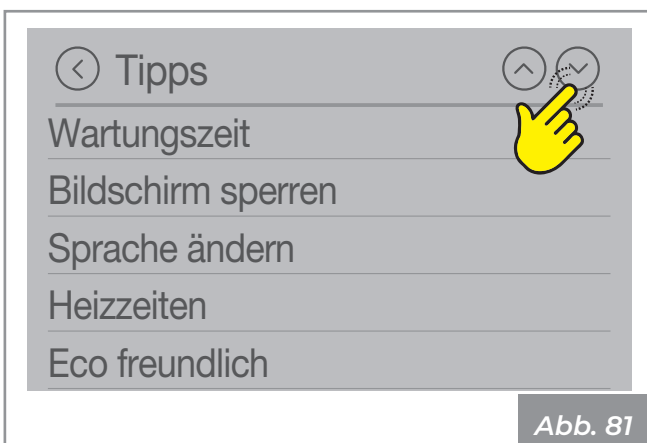
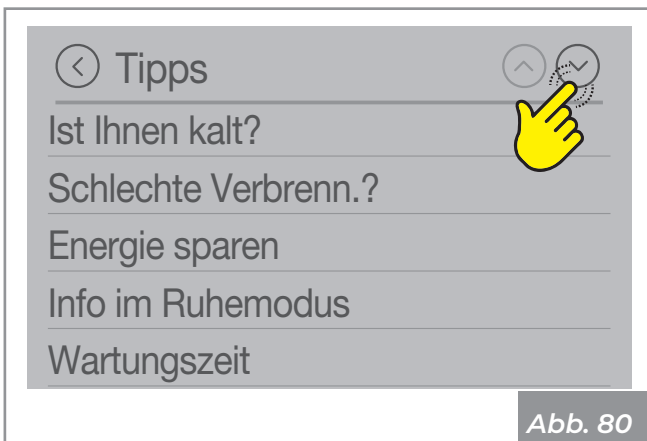
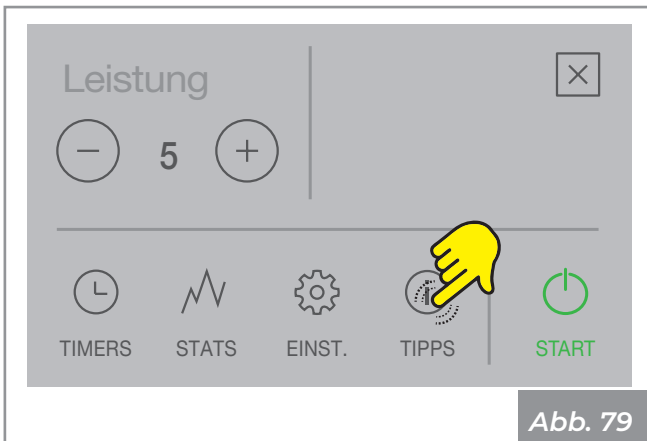

6 STÖRUNGEN UND MÖGLICHE ABHILFEN

Beim Auftreten einer Funktionsstörung wird ein akustischer Alarm (Piepton) aktiviert und das Display zeigt die mögliche Ursache mit einem numerischen Fehlercode an.

Die Fehler sind folgendermaßen unterteilt:

- **Alarmer** **E**: blockierende Fehler. Das Gerät schaltet ab. Die Ursache der Alarmermeldung muss behoben werden, bevor das Gerät erneut gezündet wird.
- **Meldungen** **!**: einfache Warnhinweise, die den Betrieb des Geräts nicht blockieren (in einigen Fällen schränken sie ihn ein). Sie werden automatisch zurückgesetzt, nachdem die Ursache, die sie erzeugt hat, behoben wurde oder nicht mehr besteht.

Beispiel von Anzeige des Alarms E102:



Abb. 83



Abb. 84

6.1 Beschreibung der Alarmer

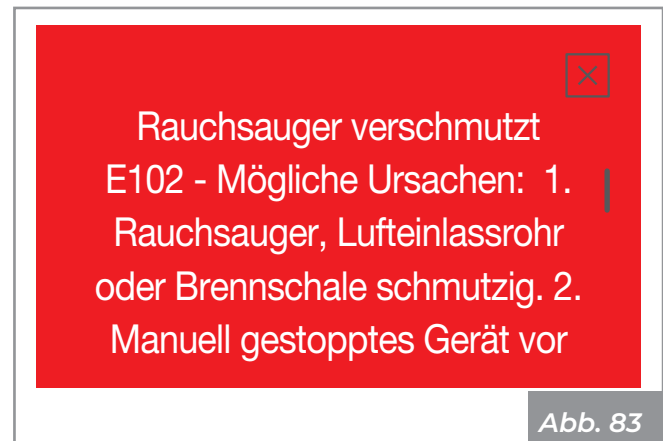
Alarm-code	Beschreibung	Mögliche Ursachen
E002	IR Komm.- Fehler	Infrarot-Sensor defekt. Service rufen.
E004	MB Komm.- Fehler	Kommunikationsfehler MB
E101	Feuer Fehler	Zündung fehlgeschlagen
E102	Rauchsauger verschmutzt	1. Rauchsauger, Lufteinlassrohr oder Brennschale schmutzig. 2. Manuell gestopptes Gerät vor der Flammendetektion.
E104	Grate blocked	Empty and clean the grate. Reset the error.
E105	NTC2 Fehler	Zur T02 angeschlossener Sensor gestört oder getrennt. Service rufen.
E106	NTC3 Fehler	Zur T05 angeschlossener Sensor gestört oder getrennt. Service rufen.
E108	Fehler Sicherheitsschalter	Schalter an I01 angeschlossen offen. Den Alarm zurücksetzen und das Gerät neu starten. Wenn der Fehler weiterhin besteht, Service rufen.
E109	Druck Fehler	Öffnen Sie den Druck- oder Wärmesicherheitssensor. Den Alarm zurücksetzen und das Gerät neu starten. Wenn der Fehler weiterhin besteht, Service rufen.
E110	NTC1	Zur T01 angeschlossener Sensor gestört oder getrennt. Service rufen.

Alarm-code	Beschreibung	Mögliche Ursachen
E111	TC1	Zur T03 angeschlossener Sensor gestört oder getrennt. Service rufen.
E113	Übertemperatur Gase	Rauchgase Übertemperatur. Wärmetauscher- oder Rauchsaugerreinigung erforderlich.
E114	Keine Zündung	Brennstoffzündung-Unterbrechung abgelaufen (die Brennschale leeren und das Gerät neu starten) oder Brennstofftank leer (den Tank nachfüllen).
E115	Allgemeiner Fehler	Kontakt mit Service aufnehmen.

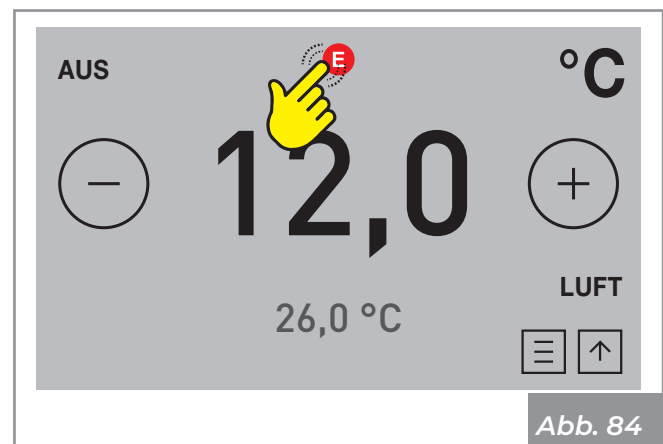
6.2 Reset der Alarme

Im Falle von Alarm wird das Display rot und es ertönt ein Signalton (Piepton).

Es werden der Alarmcode und die mögliche Ursache visualisiert.

Das Gerät schaltet ab.



Gefahr: Im Falle der Alarme "E108" oder "E109" muss vor der Rücksetzung des Alarms der Thermostat mit manueller Rückstellung auf der Rückseite des Geräts wieder aktiviert werden (von Seiten des technischen Kundendienstzentrums). Nun kann eine Neuzündung durchgeführt werden.

Wenn man durch den Druck auf **X** die Bildschirmseite schließt, wird der Alarm nicht zurückgesetzt und das Symbol **E** bleibt.

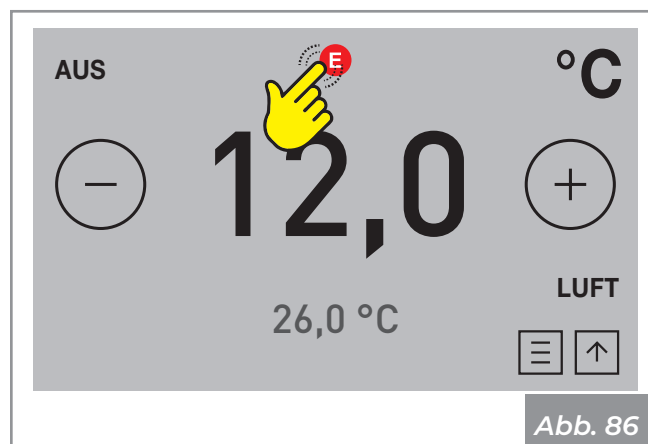

Um nochmals die Beschreibung des Alarms zu sehen, auf das Symbol **E** drücken.

Vor einer Neuzündung muss geprüft werden, dass:

- das Gerät abgekühlt ist;
- die Ursache der Alarmmeldung behoben wurde;
- die Brennschale sauber und frei von jeglichen Asche- oder Pelletrückständen ist;
- die Brennschale korrekt in ihrer Aufnahme positioniert ist;
- die Feuerraum- und Behältertüren perfekt geschlossen sind.

6.3 Beschreibung der Meldungen

Mel- dungs- code	Beschreibung	Mögliche Ursachen - Abhilfen
A001	Brennstoff niedrig	Warnung Brennstoffstand, den Tank nachfüllen.
A002	Wartung	Betriebszeit abgelaufen, Kontakt mit dem Service für die Wartung aufnehmen.
A004	Batterie leer	Schwache Batterie, für den Austausch Kontakt mit dem Service aufnehmen.
A005	Geschwindigkeitssensor	Geschwindigkeitssensorausfall - Kontakt mit dem Service aufnehmen.
A007	Druck-/Luftstromsensor	Alternativer Betriebsmodus, begrenzte Funktionalität. Luftstromsensor Fehlfunktion, Kontakt mit dem Service aufnehmen.

6.4 Reset der Meldungen

Im Falle von Meldung wird das Display gelb und es ertönt ein Signalton (Piepton).

Es werden der Meldungscode und die mögliche Ursache visualisiert.

Um nochmals die Beschreibung der Meldung zu sehen, auf das Symbol  drücken.



Um die Meldung zurückzusetzen, muss das Problem gelöst worden sein.



Abb. 87



Achtung: Im Falle von Meldung ist das Gerät noch funktionsfähig (in einigen Fällen hat es beschränkte Funktionen).

Wenn man durch den Druck auf  die Bildschirmseite schließt, wird die Meldung nicht zurückgesetzt und das Symbol  bleibt.



Abb. 88

TABLE DES MATIÈRES

1	PANNEAU DE COMMANDE	81
1.1	Description	81
1.2	Description générale des icônes	81
1.3	Arbre de navigation	82
1.4	Page initiale et température de consigne	83
2	OPÉRATIONS PRÉALABLES	85
2.1	Chargement des granulés de bois	85
2.2	Alimentation électrique	85
3	MENU PARAMÈTRES	86
3.1	Paramètres	86
3.1.1	Paramètre « Temps »	87
3.1.2	Paramètre « Date »	87
3.1.3	Fonction « Combustible »	87
3.1.4	Fonction « Mode écologique »	88
3.1.5	Fonction « Antigel »	88
3.1.6	Afficheur	89
3.1.7	Fonction « Nettoyage écran »	90
3.1.8	Paramètre « Unité de température »	90
3.1.9	Paramètres « Haut-parleur »	91
3.1.10	Fonction « Temps de service »	91
3.1.11	Menu Installateur	91
3.1.12	Menu de service	92
3.1.13	Fonction « Verrouillage écran »	92
3.1.14	Langue	93
3.1.15	Informations	93

4 UTILISATION	94
4.1 Allumage	94
4.1.1 Modification de la température ambiante	95
4.1.2 Modification de la puissance	95
4.2 Modification des paramètres	95
4.3 Arrêt	96
4.4 Rallumage après une coupure de courant	96
4.5 Fonctionnement avec thermostat d'ambiance	97
4.6 Fonctionnement avec une sonde d'ambiance intégrée dans le poêle	97
5 FONCTIONS DISPONIBLES	98
5.1 Paramètre chrono	98
5.1.1 Activation/désactivation du chrono	98
5.2 Stats	99
5.3 Suggestions de fonctionnement	100
6 ANOMALIES ET SOLUTIONS POSSIBLES	101
6.1 Description des alarmes	101
6.2 Réinitialisation des alarmes	102
6.3 Description des avertissements	103
6.4 Réinitialisation des avertissements	103

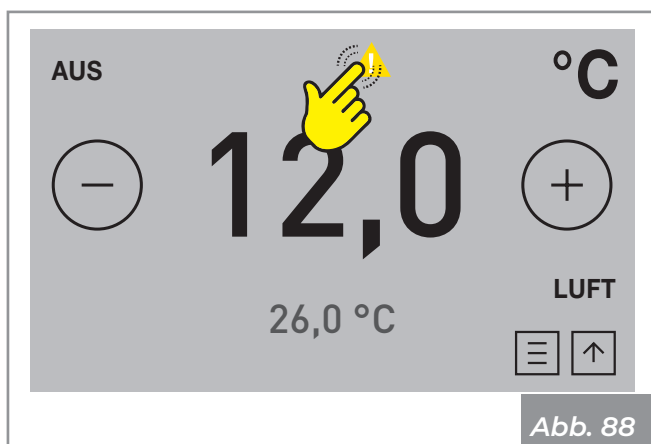
SYMBOLES UTILISÉS DANS LE MANUEL ET LEUR SIGNIFICATION



Indication : Pour indiquer des informations particulières.



Attention : Pour indiquer des opérations particulièrement importantes et délicates.



Danger : Pour indiquer des actions, qui, en l'absence d'exécution correcte, peuvent provoquer des accidents d'origine générale, des dysfonctionnements ou des dommages matériels à l'appareil.

1 PANNEAU DE COMMANDE

1.1 Description

Le panneau de commande est composé de :

- 1) Récepteur IR (infrarouge)
- 2) Capteur de lumière ambiante
- 3) Écran tactile
- 4) Haut-parleurs
- 5) Connecteur RJ11

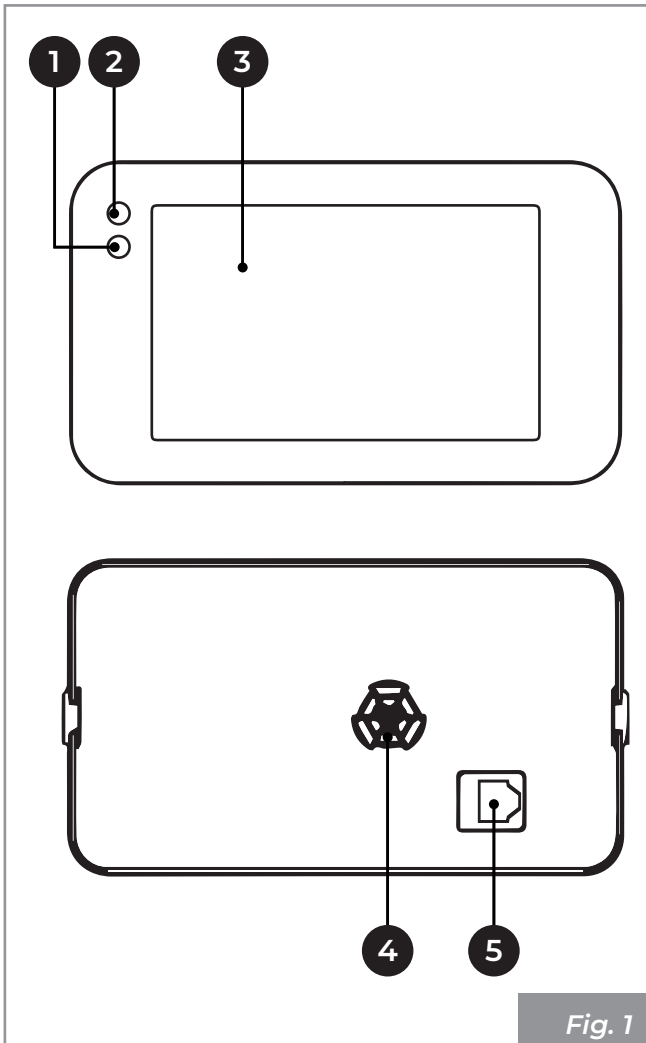

Fig. 1



Indication : L'écran est de type tactile ; il suffit donc d'effleurer la surface, sans pression.

1.2 Description générale des icônes

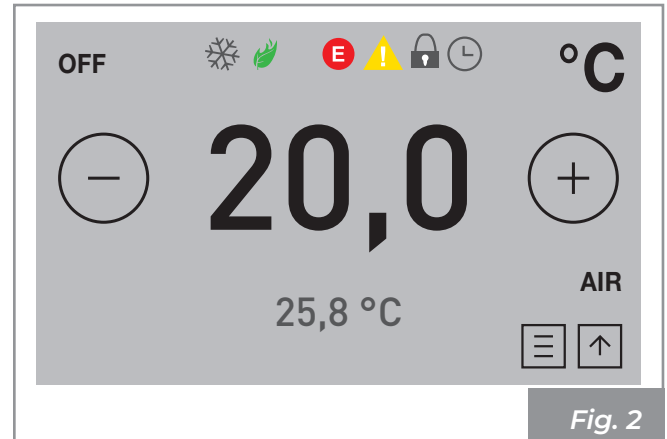

Fig. 2

Icône	Description
	Alarme
	Avertissement
	Fonction Mode écologique
	Menu principal
	Allumage de l'appareil
	Chrono activé
	Fonction « Antigel » active
	Verrouillage écran
OFF	Indication appareil éteint
20.0	Température définie
25.8	Température relevée par la sonde

1.3 Arbre de navigation

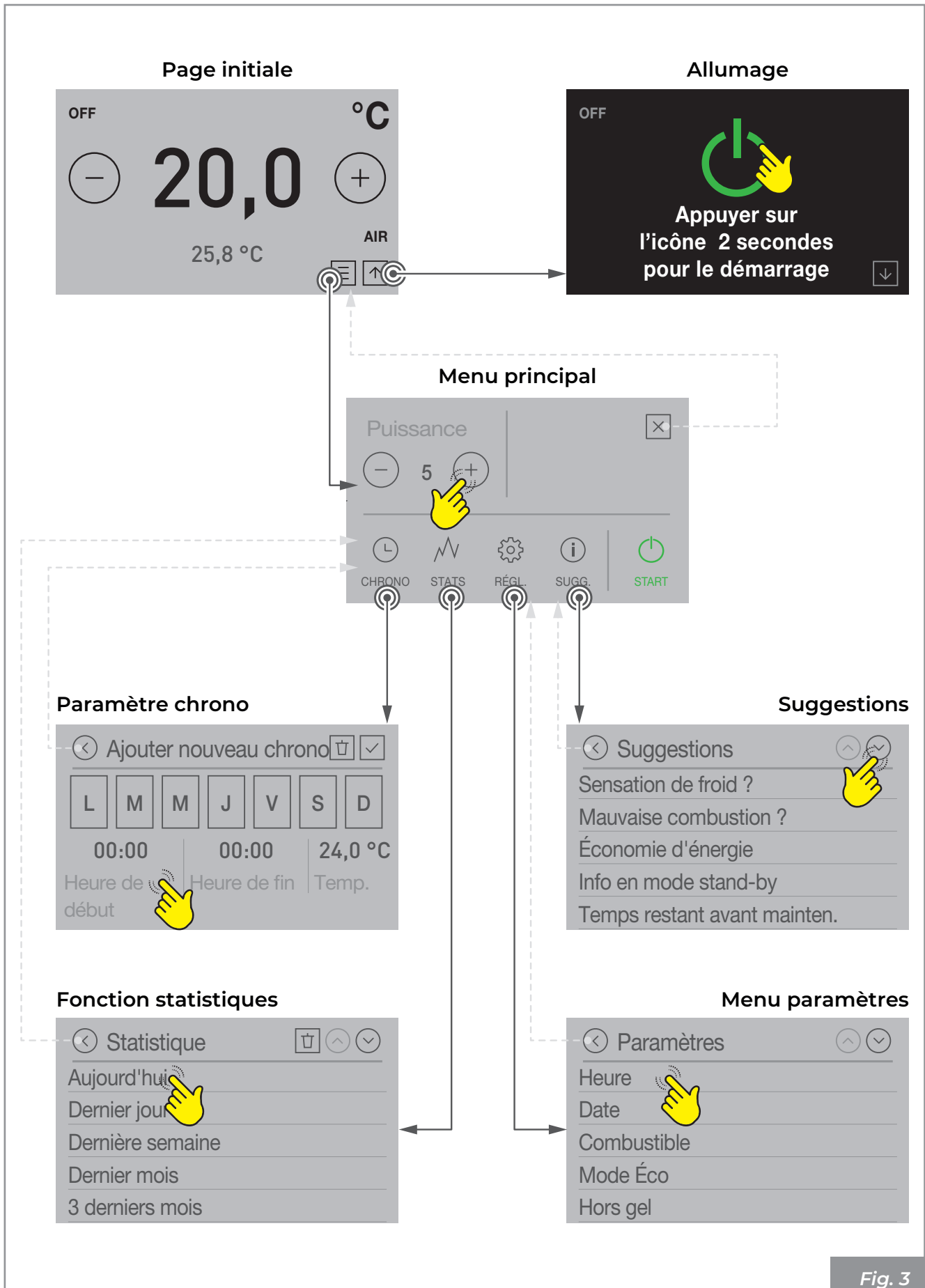

Fig. 3

1.4 Page initiale et température de consigne

Les pages initiales et les valeurs de température qui s'affichent dépendent de la configuration d'installation de l'appareil.

Configuration 1 - Thermostat d'ambiance

Page initiale

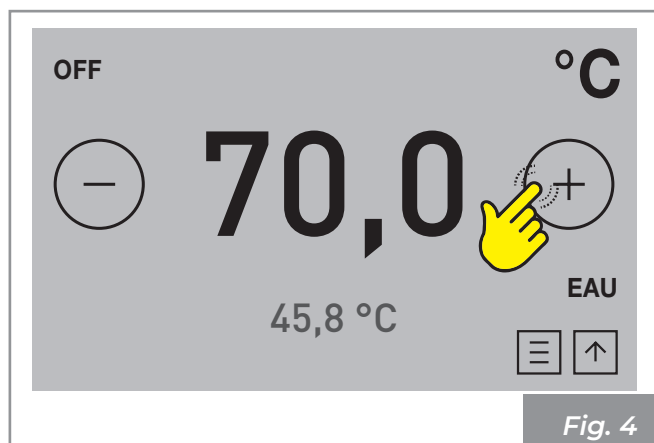

Cette page concerne la température de départ de l'eau chaude de la chaudière.

Appuyer sur l'icône ⊕ ou ⊖ pour varier la température souhaitée de départ (grands chiffres)
Les valeurs peuvent être définies de 45°C à 80°C.

Les petits chiffres indiquent la température effectivement relevée par la sonde de départ

Appuyer sur « **EAU** ». L'affichage est le suivant :

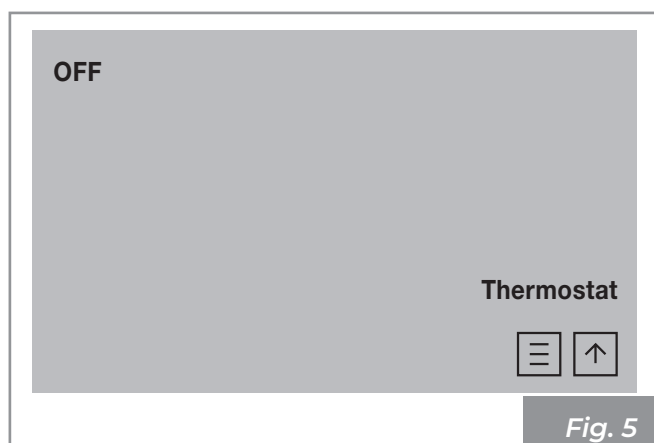

Appuyer sur « **Thermostat** » pour revenir à la page précédente.

Configuration 2 - Sonde d'ambiance

Page initiale

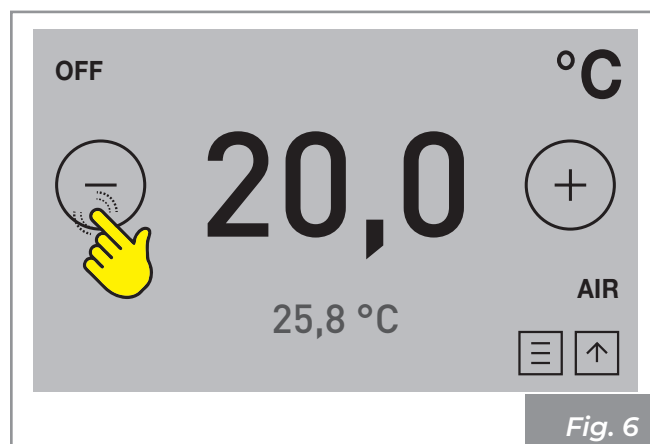

Cette page concerne la température ambiante.

Appuyer sur l'icône ⊕ ou ⊖ pour varier la température à atteindre dans la pièce (grands chiffres)
Les valeurs peuvent être définies de 10°C à 40°C.

Les petits chiffres indiquent la température ambiante relevée par la sonde placée sur l'appareil

Appuyer sur « **AIR** ». On passe à l'affichage de la température de départ de l'eau chaude de la chaudière :

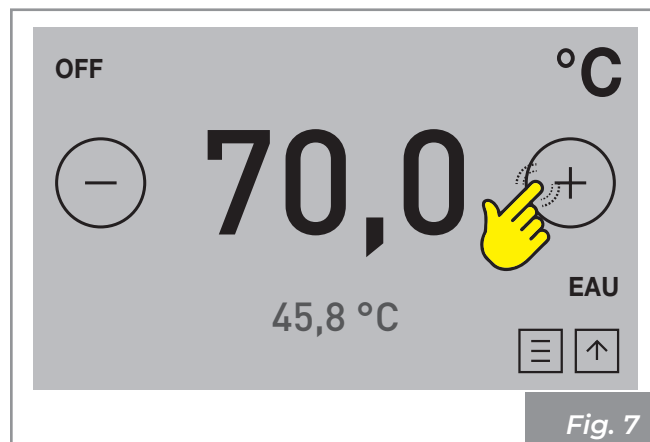

Appuyer sur l'icône ⊕ ou ⊖ pour varier la température souhaitée de départ (grands chiffres)
Les valeurs peuvent être définies de 45°C à 80°C.

Les petits chiffres indiquent la température effectivement relevée par la sonde de départ

Configuration 3/4 - Accumulation avec/sans serpentín

Page initiale

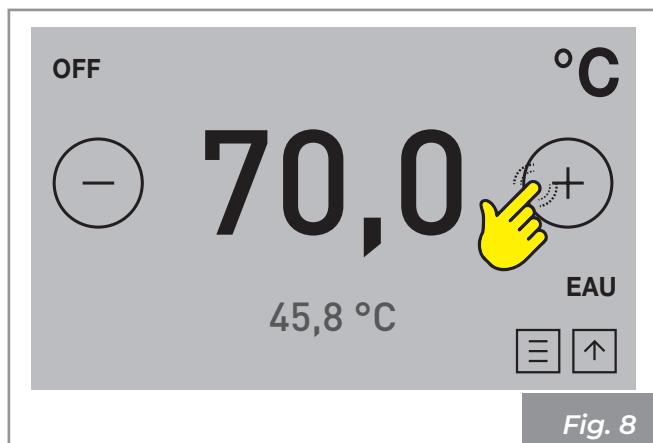

Cette page concerne la température de l'eau chaude à l'intérieur de l'accumulateur.

Appuyer sur l'icône ⊕ ou ⊖ pour varier la température à maintenir à l'intérieur de l'accumulateur (grands chiffres)

Les valeurs peuvent être définies de 45°C à 80°C.

Les petits chiffres indiquent la température effectivement relevée par la sonde présente dans l'accumulateur

2 OPÉRATIONS PRÉALABLES

2.1 Chargement des granulés de bois

La première opération à réaliser avant d'allumer le produit est celle de remplir le réservoir à combustible (pellet) en utilisant de préférence une pelle spéciale.

Ne pas vider le sac directement dans le réservoir pour éviter de charger la sciure ou d'autres éléments étrangers qui pourraient compromettre le bon fonctionnement de l'appareil et pour éviter de répandre des granulés en dehors du réservoir.

Indication : Veiller à bien refermer le couvercle du réservoir après avoir réalisé l'opération de chargement du pellet. Un interrupteur de sécurité « IS » (sur les modèles qui le prévoient) vérifier sa fermeture correcte et met l'appareil en alarme si le couvercle est laissé ouvert pendant plus d'une minute avec l'appareil en marche.

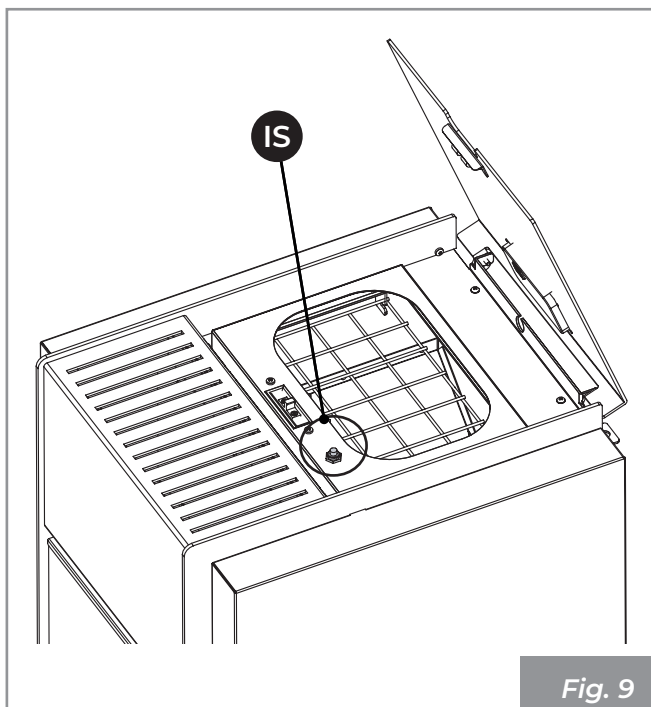

Fig. 9

2.2 Alimentation électrique

Brancher l'appareil au secteur électrique, agir sur l'interrupteur d'allumage placé au dos de l'appareil en le plaçant sur « I ».

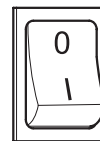

Fig. 10

Si le branchement est correct, l'appareil émet une série de signaux sonores intermittents et l'écran s'allume.



Attention : En cas de périodes prolongées d'inutilisation, il est conseillé de mettre l'interrupteur situé au dos de l'appareil sur OFF (0).



Indication : Veiller à ne pas toucher le panneau de commande au moment de la mise sous tension de l'appareil.

Le logo initial s'affiche en alimentant l'appareil.



Fig. 11

La page initiale apparaît au bout de quelques secondes :

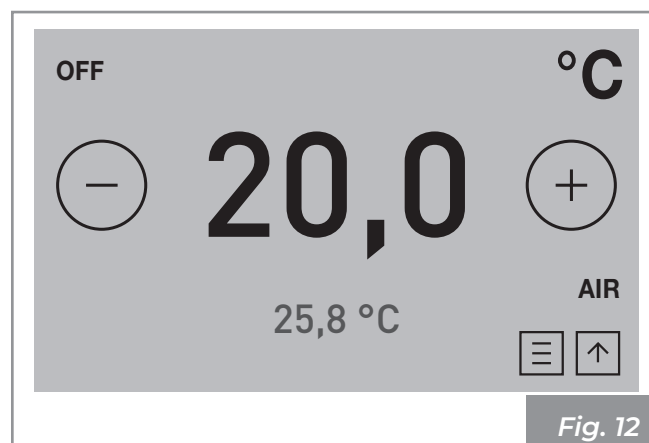



Fig. 12

3 MENU PARAMÈTRES

3.1 Paramètres

Appuyer sur l'icône  pour accéder au menu paramètres.

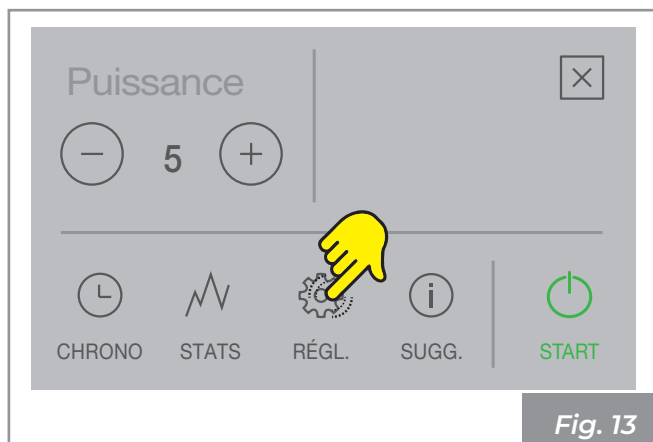



Fig. 13

Appuyer sur  et  pour parcourir la liste des paramètres.

Appuyer sur le paramètre souhaité pour ouvrir la page de modification de ce paramètre.

Les paramètres sont en général modifiables en appuyant sur l'icône  ou .

Appuyer sur  pour confirmer ou sur  pour fermer la page de modification sans sauvegarder.

Liste des paramètres

Paramètre	Description	Valeurs définissables	Valeurs par défaut
Heure	Réglage heure	Date et Heure correctement réglées	
Date	Réglage date		
Combustible	Il est possible de définir 3 configurations différentes de combustion	1 ... 3	1
Mode écologique *	Active le Mode écologique	ON ; OFF	<input type="checkbox"/> ON
Antigel *	Température minimale en dessous de laquelle l'appareil s'allume	OFF ; 3 ... 20 °C (OFF ; 3 ... 50 °C)	OFF
Options écran	Règle le degré de luminosité et les informations de l'écran en veille		
Unité de températ.	Unité de mesure de la température	°C ... °F	°C
Haut-parleur	Règle le niveau du volume	OFF ; 1 ... 5	2
Temps de service	Affiche les heures restantes avant l'entretien périodique.		2016 h
Menu installateur	Modifie/Affiche la configuration de l'appareil	PWD : « 54 »	
Menu de service	Menu de compétence du centre d'assistance		
Verrouillage écran	Règle la modalité de blocage des touches	OFF ; LOW ; HI	OFF
Langue	Définit la langue de l'écran :	English Italiano Deutsch Español Français Português Bosanski jezik Slovenscina Swedish Dutch Romana	English
Info	Affiche les informations système		

(*) Paramètre disponible uniquement dans certaines configurations

3.1.1 Paramètre « Temps »

Pour régler l'heure :

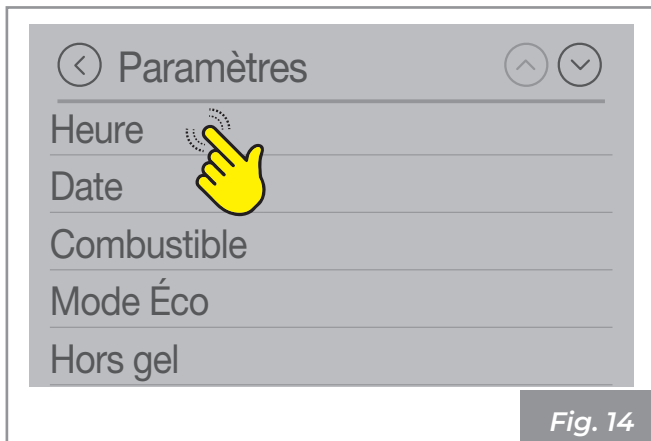

Fig. 14

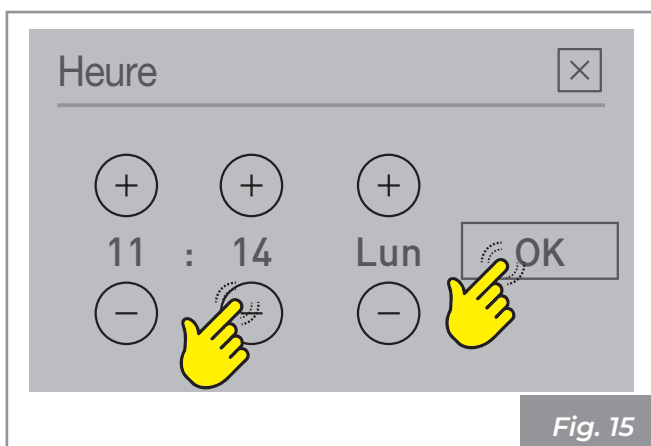

Fig. 15

3.1.2 Paramètre « Date »

Pour régler la date :

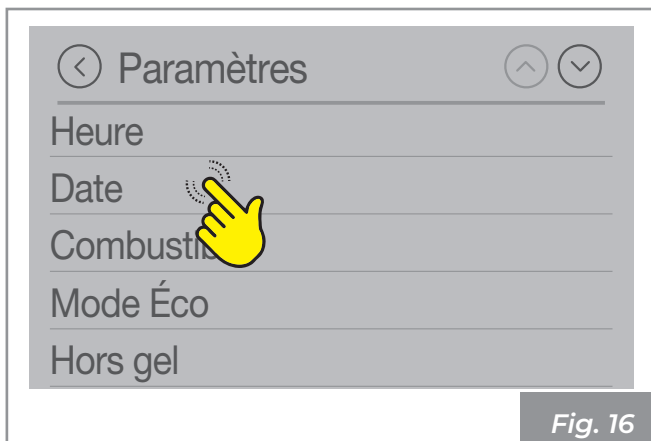

Fig. 16

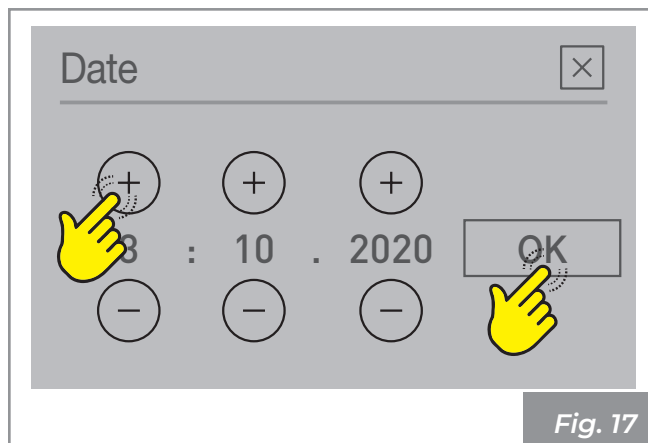

Fig. 17

3.1.3 Fonction « Combustible »

Une combustion optimale dépend de plusieurs facteurs (type d'installation, conditions de fonctionnement et de maintenance, type de pellet, etc.)

En règle générale, si de nombreux résidus sont présents dans le brazéro à la fin de la combustion, il est recommandable de modifier les configurations de combustion (en augmentant la valeur) jusqu'à l'obtention de la solution la plus satisfaisante.



Fig. 18

Optimisation de la combustion :

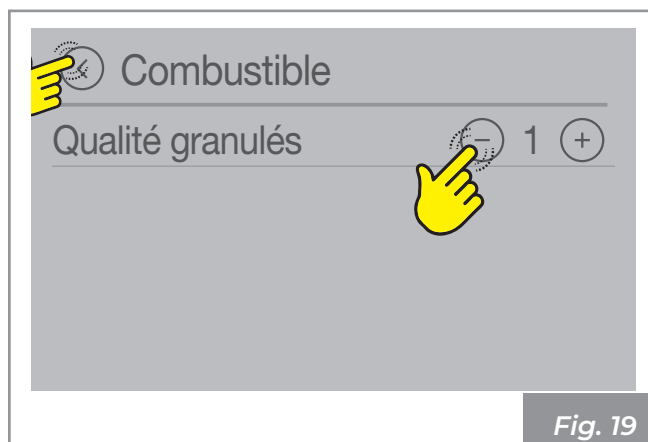

Fig. 19

Les valeurs peuvent être définies de 1 à 3.

- 1) Pellet de grande qualité (En Plus)
- 2) Pellet de moyenne qualité
- 3) Pellet de basse qualité

3.1.4 Fonction « Mode écologique »

Fonction disponible uniquement dans la configuration 2.

En activant cette fonction, l'appareil s'éteint quand la température souhaitée de la pièce est atteinte.

Si cette fonction n'est pas activée, l'appareil module son fonctionnement sans s'éteindre.

Pour activer/désactiver cette fonction :



Fig. 20

	Fonction « Mode écologique » inactive
	Fonction « Mode écologique » active

En activant la fonction « Mode écologique », la « Redémarr. temp. » devient disponible. Il s'agit du nombre de degrés en dessous de la température définie au-delà duquel l'appareil se rallume automatiquement.

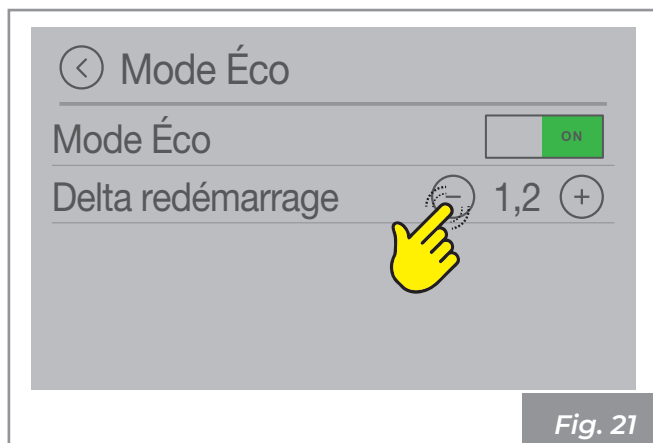

Fig. 21

Exemple : si l'appareil est configuré pour s'éteindre à 20°C (fonction « Mode écologique » active) et que l'on définit une « Redémarr. temp. » de 4°C, l'appareil se rallumera quand il détectera une température inférieure ou égale à 16°C. Les valeurs peuvent être définies entre 0,5 ... 5,0 °C.

3.1.5 Fonction « Antigel »

Fonction disponible uniquement dans les configurations 2, 3 et 4.

Il est possible de définir une température minimale en dessous de laquelle l'appareil s'allume (en dehors des créneaux horaires définis, et uniquement si le chrono est actif).

Pour modifier la valeur de la température « anti-gel » :

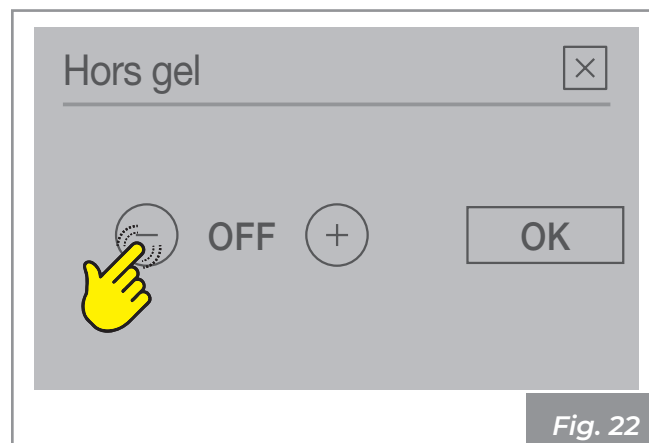

Fig. 22

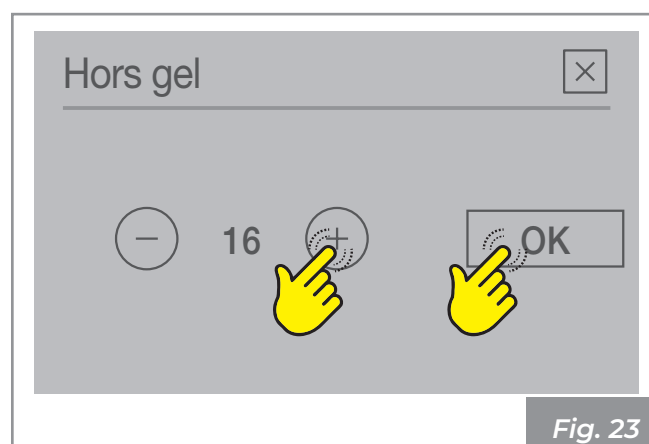

Fig. 23

Les valeurs pouvant être définies :
 (OFF ; 3 ... 20°C) pour la configuration 2
 (OFF ; 3 ... 50°C) pour les configurations 3 et 4

3.1.6 Afficheur

Appuyer sur « Options écran » pour modifier les caractéristiques d'affichage de l'écran.

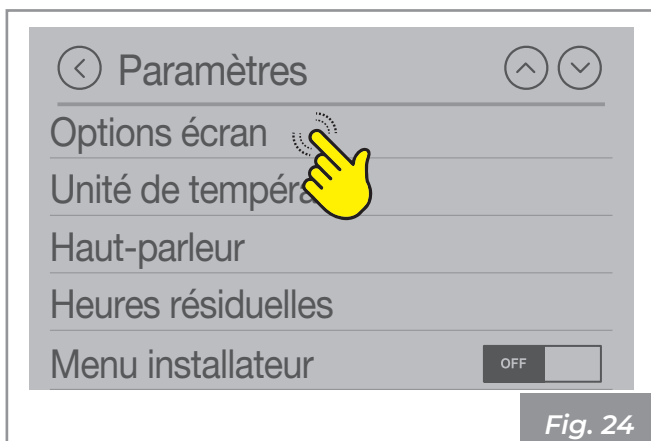

Fig. 24

Luminosité d'Écran

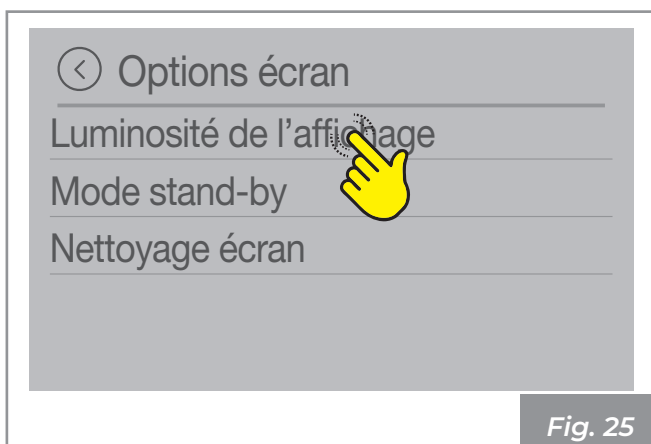

Fig. 25

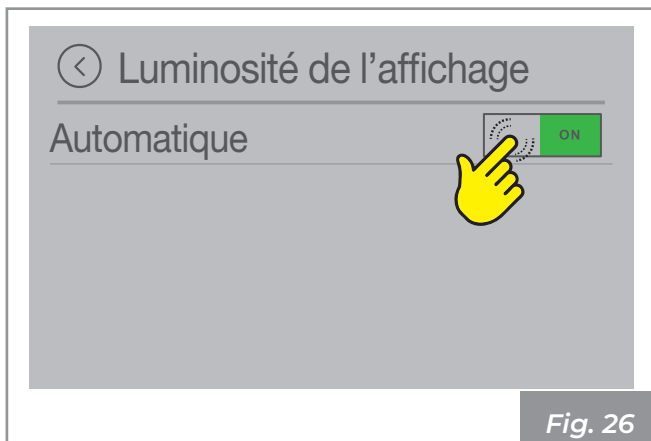

Fig. 26

Automatique : réglage en fonction du capteur de luminosité

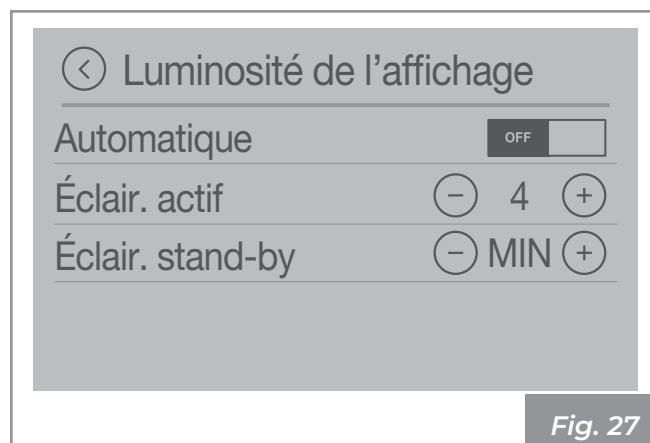

Fig. 27

Luminosité durant l'utilisation de l'écran : de 0 à 100% de luminosité
Les valeurs pouvant être définies : MIN - 2 - 3 - 4 - MAX;

Luminosité de l'écran en mode veille : de 0 à 50% de luminosité
• OFF
• MIN - 2 - 3 - 4 - MAX

Sur OFF, l'écran devient noir au bout de 60 secondes d'inutilisation et se rallume en le touchant.

Écran en « Mode veille »

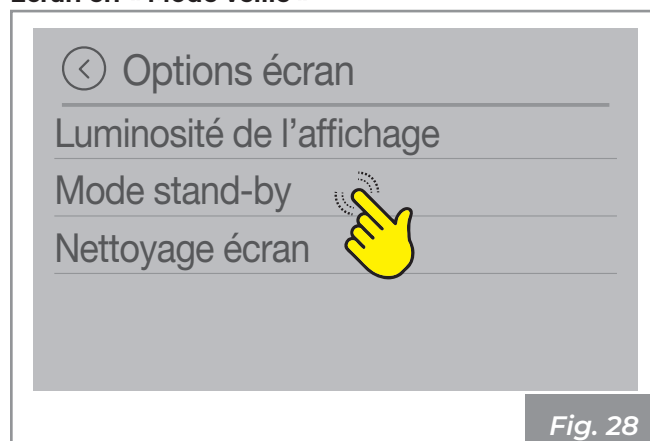

Fig. 28

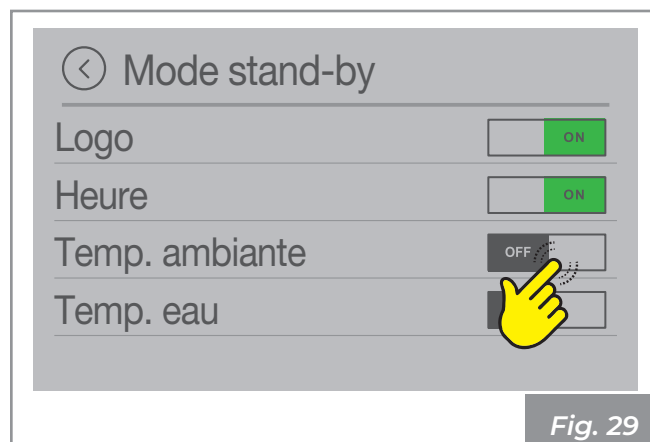

Fig. 29

Il est possible de choisir l'affichage quand l'écran est en veille :

- Logo
- Heure
- Température ambiante
- Température de l'eau

Exemple de pages qui s'alternent par cycle quand l'écran est en veille :

Heure et date

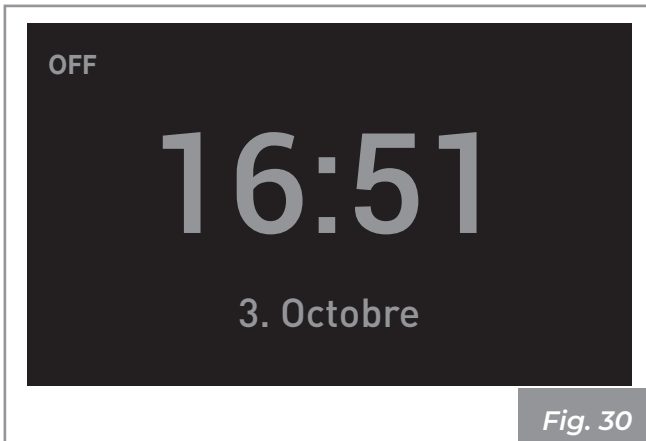

Fig. 30

Température ambiante

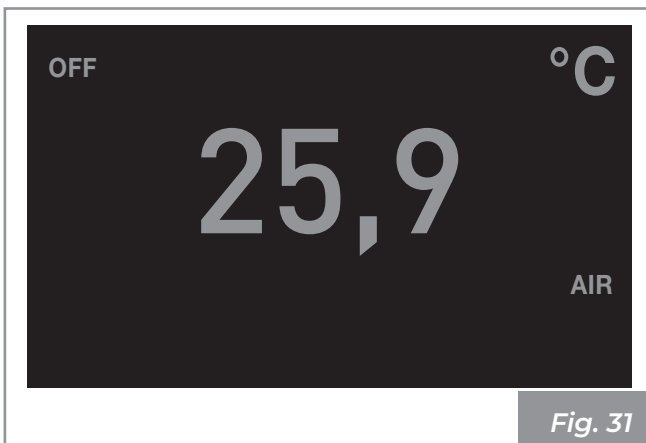

Fig. 31

3.1.7 Fonction « Nettoyage écran »

Paramètre pour effectuer le nettoyage de l'écran

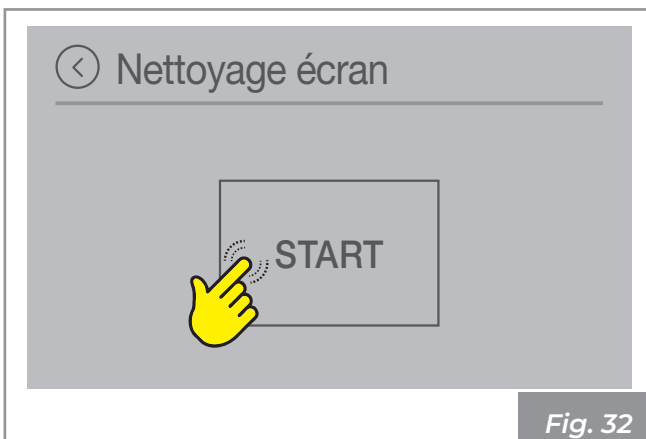

Fig. 32

Appuyer sur « START » : un compte-à-rebours démarre, le signal sonore BIP indique que l'écran est inactif et il est possible de procéder au nettoyage sans interférer avec ses fonctionnalités. À la fin du compte à rebours, l'écran tactile redevient actif.

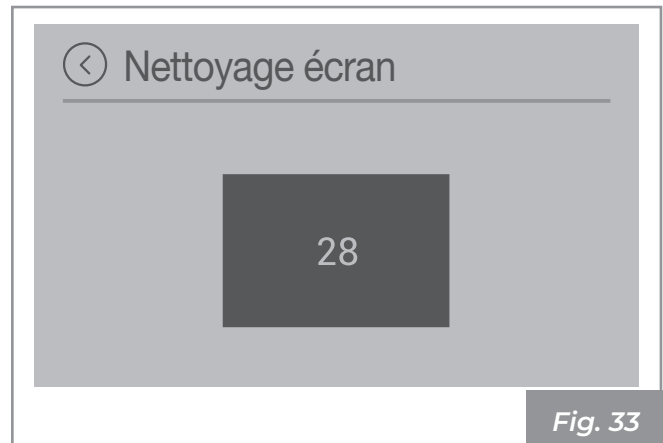

Fig. 33

3.1.8 Paramètre « Unité de température »

Pour modifier l'unité de mesure de la température :

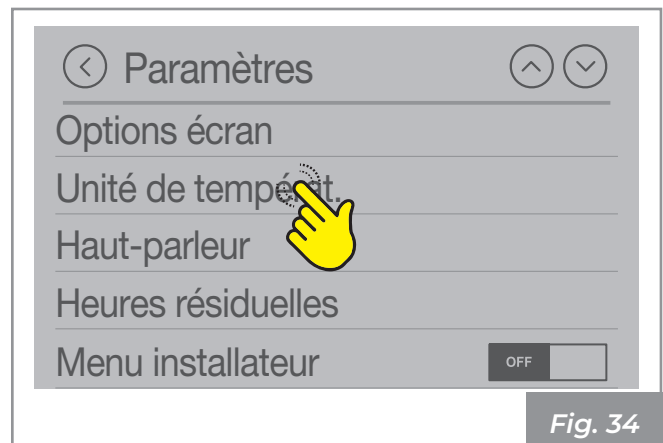

Fig. 34

Pour passer de °C à °F, appuyer sur ⊕ ou sur ⊖. Appuyer sur pour confirmer.



Fig. 35

3.1.9 Paramètres « Haut-parleur »

Pour modifier le niveau d'intensité du haut-parleur :

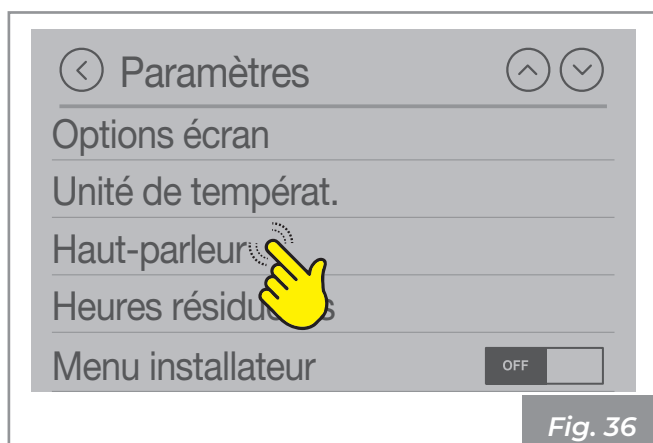

Fig. 36

Appuyer sur \oplus et \ominus pour définir le niveau de volume souhaité (OFF, 1 ... 5).

Appuyer sur **OK** pour confirmer.



Fig. 37

3.1.10 Fonction « Temps de service »

Indique le temps restant avant le prochain entretien périodique.

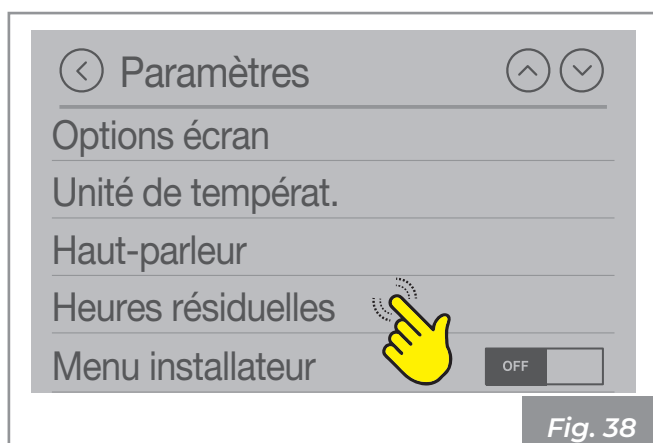

Fig. 38

Affiche les heures restantes avant l'entretien périodique.

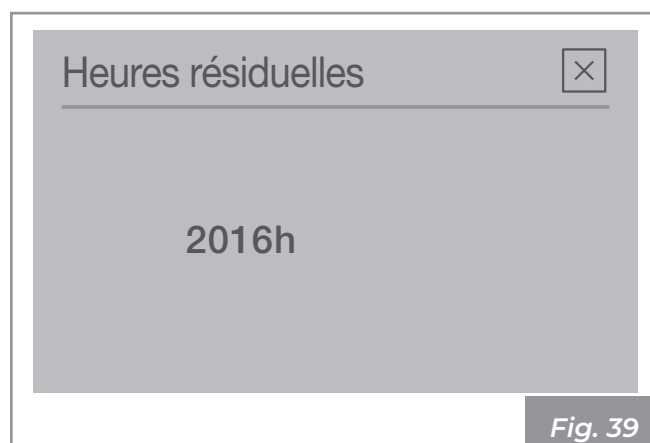

Fig. 39

3.1.11 Menu Installateur



Danger : Les sous-menus sont protégés par mot de passe et sont exclusivement réservés au centre d'assistance.

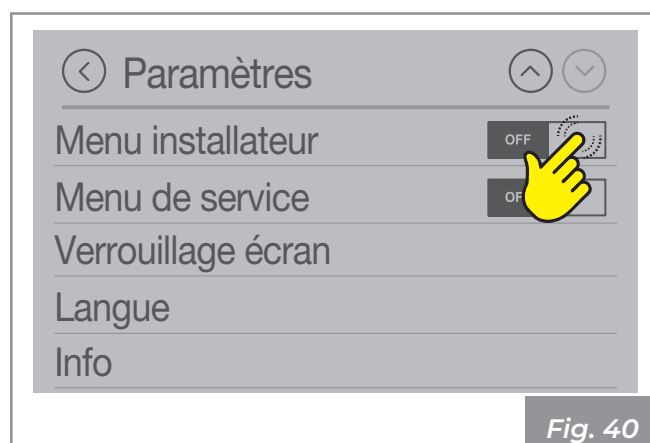

Fig. 40

Appuyer sur **ON** : le mot de passe apparaît, saisir **54** et appuyer sur **OK** pour confirmer.

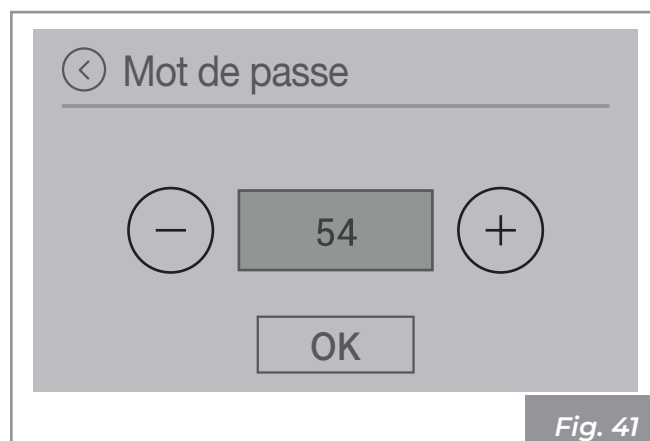

Fig. 41

Appuyer sur « **Configurations** ».

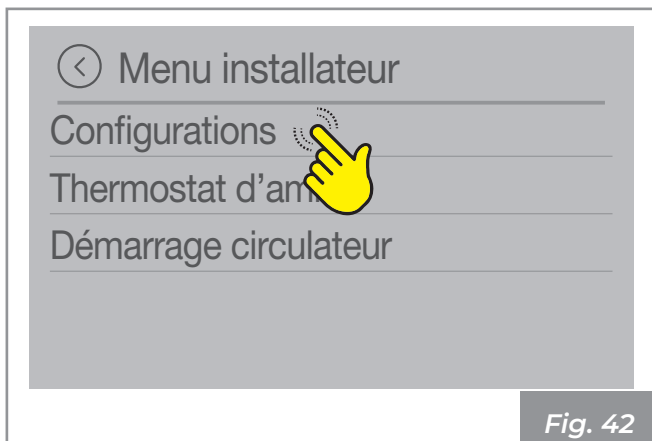

Fig. 42

Affiche les configurations possibles de l'appareil. La configuration actuellement définie est sur ON, toutes les autres sur OFF.

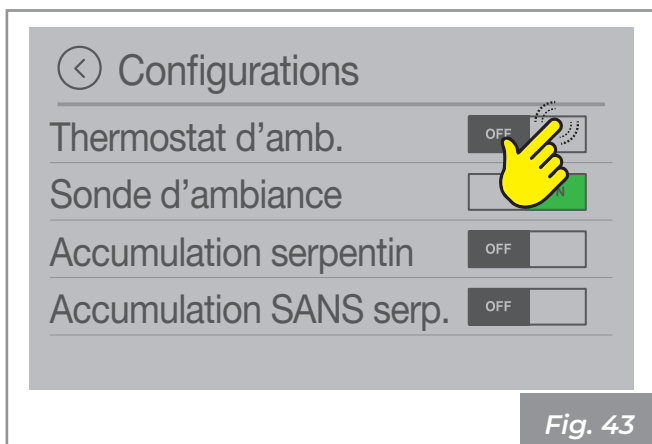

Fig. 43

Configu-ration	Description	Par défaut
1	Thermostat d'ambiance	OFF <input type="checkbox"/>
2	Sonde d'ambiance	<input checked="" type="checkbox"/> ON
3	Accumulation avec serpentin	OFF <input type="checkbox"/>
4	Accumulation sans serpentin	OFF <input type="checkbox"/>

Faire référence à la configuration de l'appareil sur le manuel d'installation.

3.1.12 Menu de service



Danger : Les sous-menus sont protégés par mot de passe et sont exclusivement réservés au centre d'assistance.

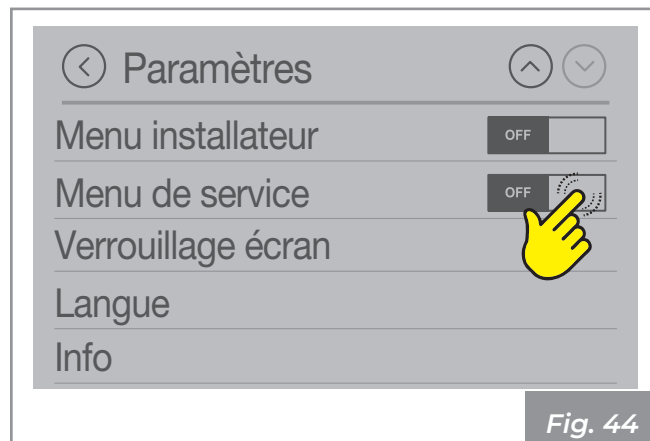

Fig. 44

3.1.13 Fonction « Verrouillage écran »

Pour verrouiller l'accès aux fonctionnalités de l'écran :

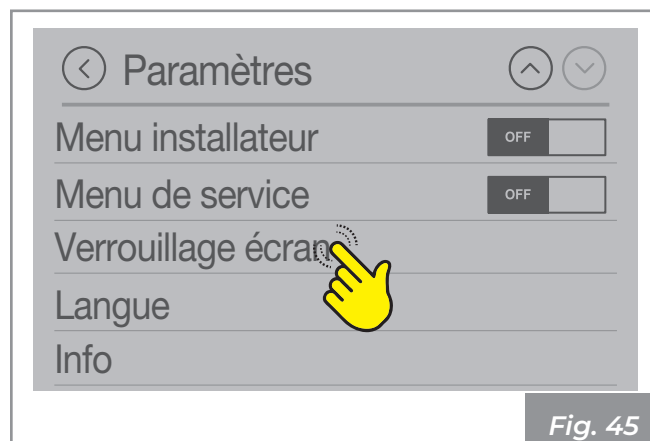

Fig. 45

- **OFF** : Verrouillage écran désactivé
- **LOW** : Verrouillage écran partiel
- **HI** : Verrouillage écran activé

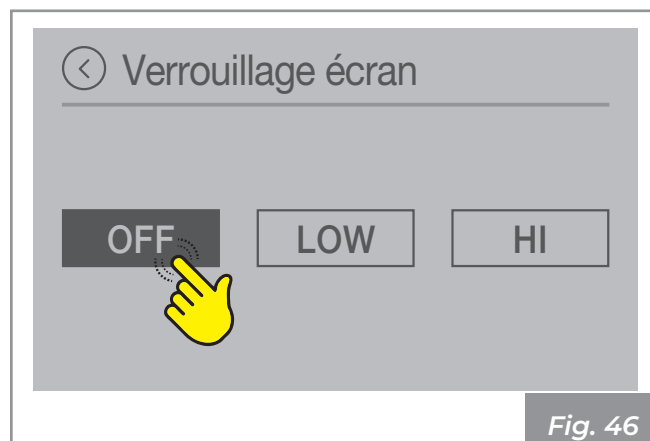

Fig. 46

Pour désactiver la fonction, entrer dans « Verrouillage écran » et sélectionner **OFF**.

3.1.14 Langue

Pour sélectionner la langue :

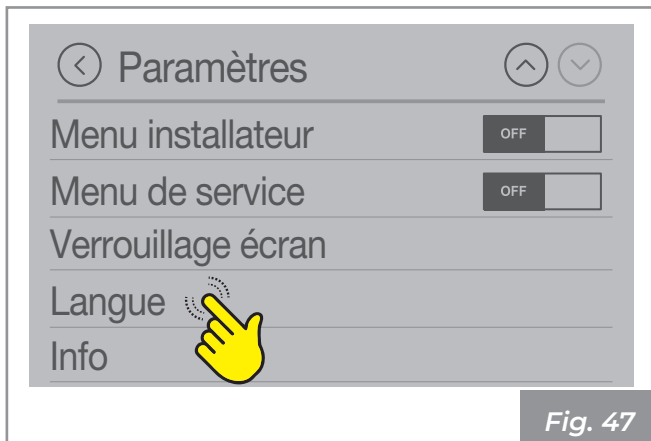

Fig. 47

3.1.15 Informations

Pour afficher les informations système :

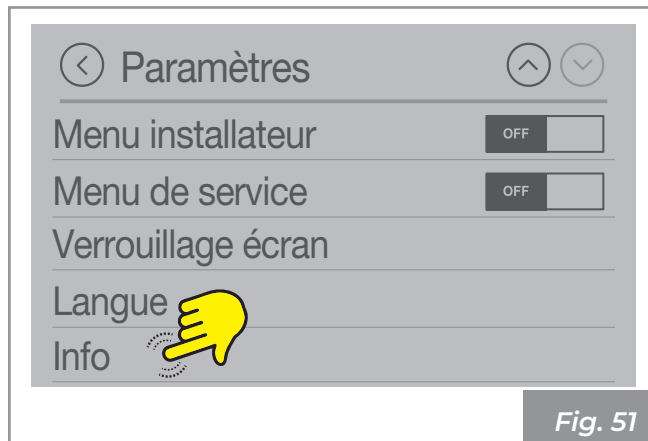

Fig. 51

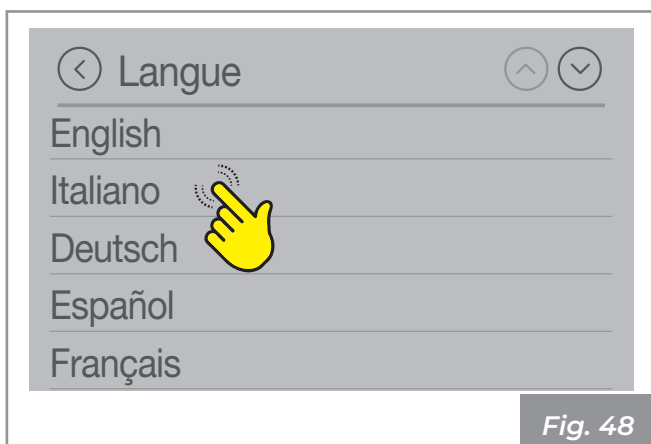

Fig. 48

Affiche la version logicielle actuelle.

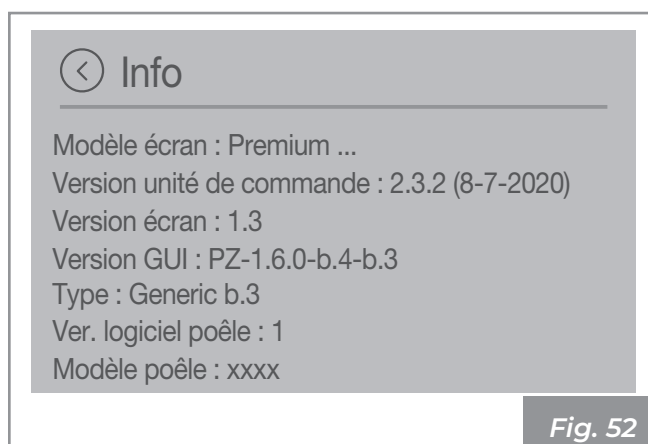

Fig. 52



Fig. 49

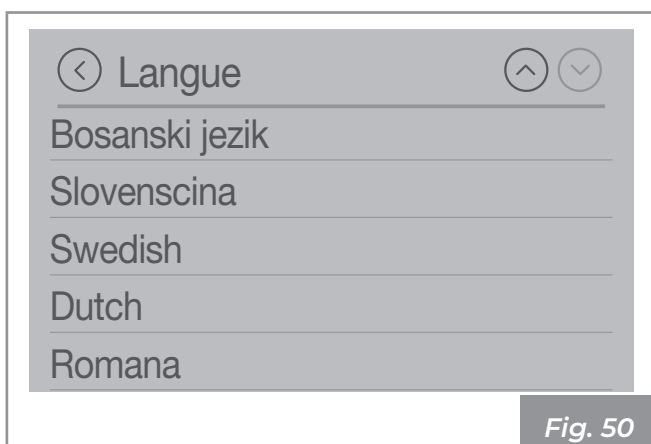

Fig. 50

4 UTILISATION

4.1 Allumage



Danger : Avant chaque allumage, s'assurer que le brazéro est complètement vide et correctement placé dans son logement.

Il existe deux modalités de démarrage de l'appareil.

Première modalité :

Appuyer sur l'icône 

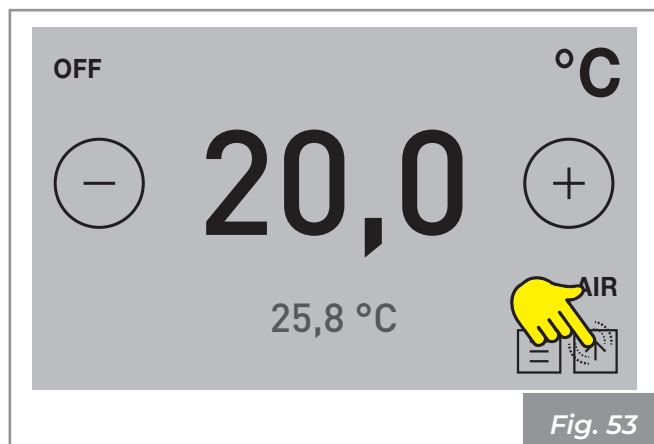

Fig. 53

Maintenir l'icône enfoncée pendant deux secondes pour démarrer le produit.



Fig. 54

Deuxième modalité :

Accéder au menu principal et maintenir START enfoncé pendant quelques secondes.

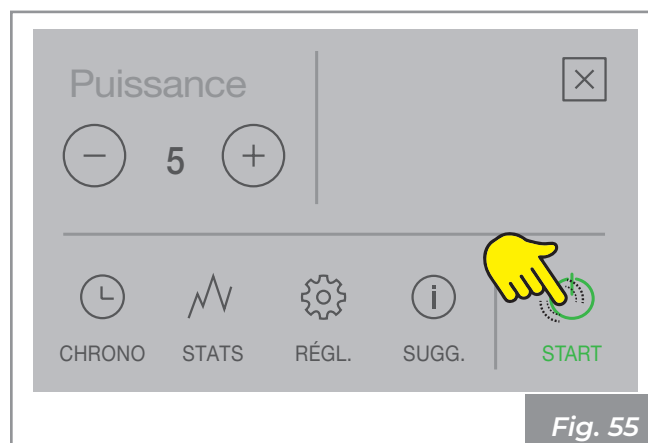

Fig. 55

L'appareil commence alors la phase d'allumage. La séquence est la suivante :

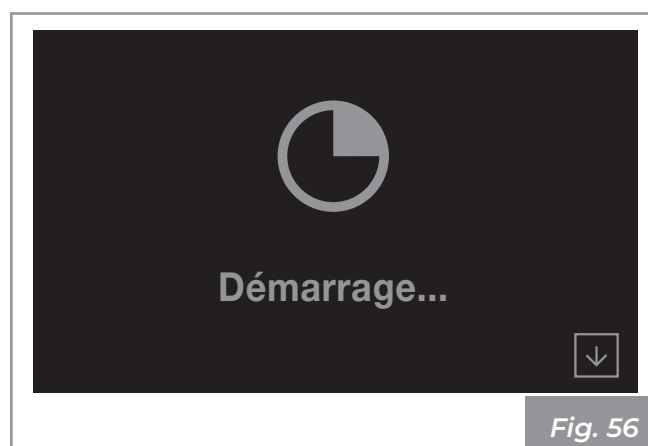

Fig. 56

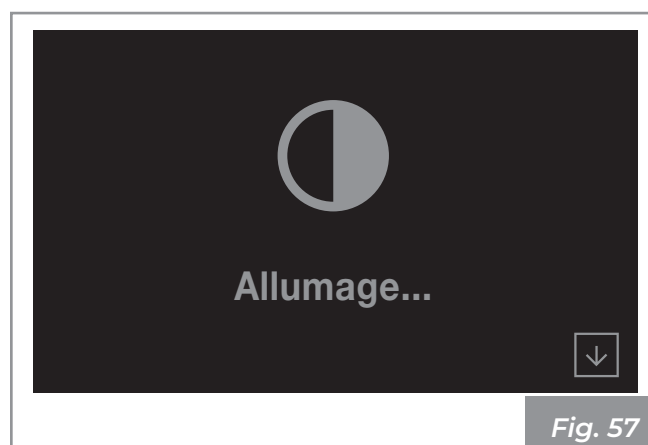
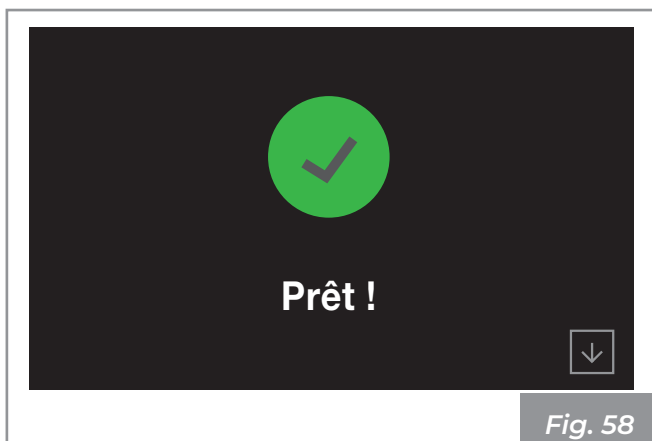
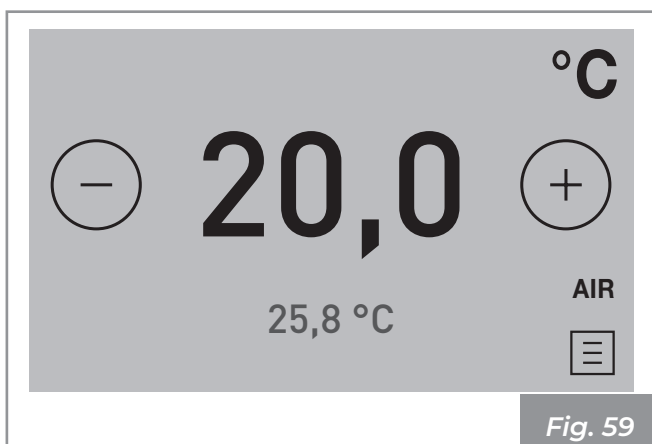

Fig. 57



La page initiale apparaît au bout de quelques secondes :



Attention : Allumage automatique : l'appareil est doté d'un dispositif automatique qui permet l'allumage du pellet sans devoir utiliser d'autres méthodes d'allumage traditionnelles.



Danger : Éviter d'allumer manuellement l'appareil si le système d'allumage automatique est compromis.



Attention : Les mauvaises odeurs ou les fumées lors du premier allumage de l'appareil sont liées à l'évaporation ou le séchage de certains matériaux utilisés. Ce phénomène diminuera jusqu'à disparaître complètement.

Nous conseillons, pour les premiers feux, de bien aérer les pièces.

Appareils de la série « Ermetica » :

À chaque ouverture de la porte du foyer, éviter de la laisser ouverte longtemps afin d'éviter que le capteur de fermeture signale le statut de porte ouverte, à travers une alarme sonore.

4.1.1 Modification de la température ambiante

La modification de cette valeur permet de définir la température à atteindre dans la pièce, qui est directement lue par une sonde placée sur l'appareil.

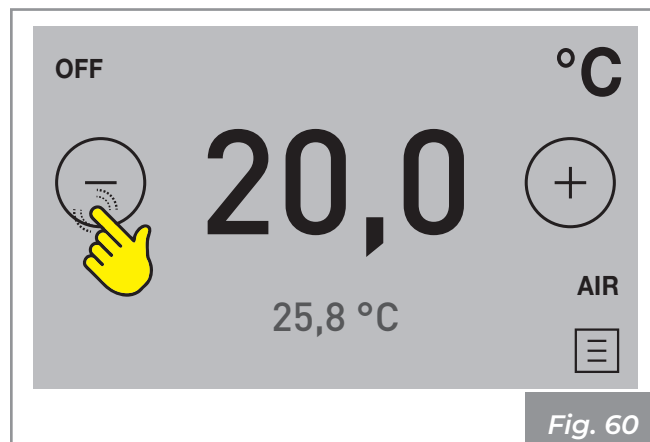

Pour modifier la valeur de la température, appuyer sur l'icône ⊕ ou ⊖ :

Les valeurs peuvent être définies de 10°C à 40°C.

4.1.2 Modification de la puissance

La puissance définit la quantité de chaleur produite par l'appareil et a par conséquent une influence sur la consommation.

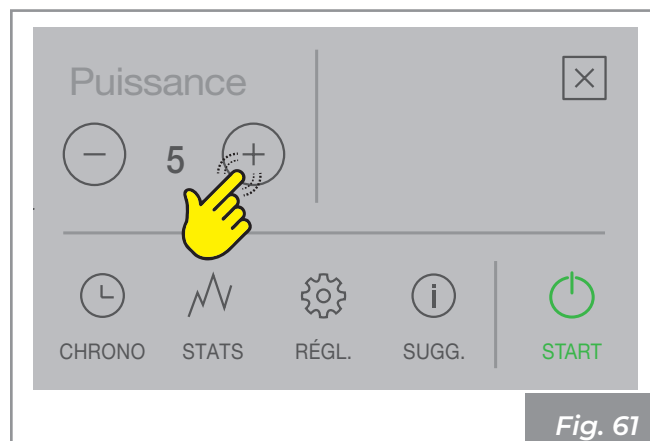

Pour modifier la valeur de la puissance, appuyer sur l'icône ⊕ ou ⊖ :

Les valeurs peuvent être définies de 1 (minimum) à 5 (maximum).

4.2 Modification des paramètres

Il est possible de modifier les paramètres de fonctionnement selon les indications du chapitre « 3 Menu paramètres »



Indication : Les valeurs définies seront conservées jusqu'à la prochaine variation, même quand l'appareil est éteint ou débranché de l'alimentation électrique.

4.3 Arrêt

Pour éteindre l'appareil, maintenir la touche STOP enfoncée pendant quelques secondes ;

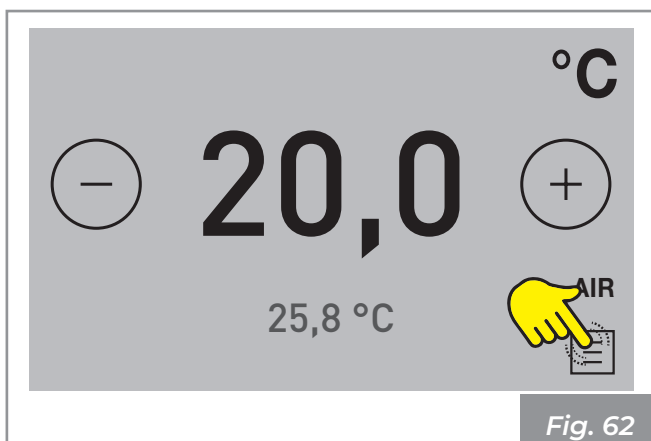

Fig. 62

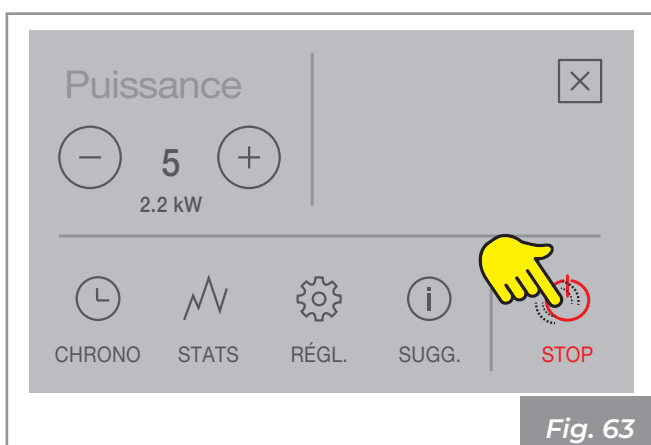

Fig. 63

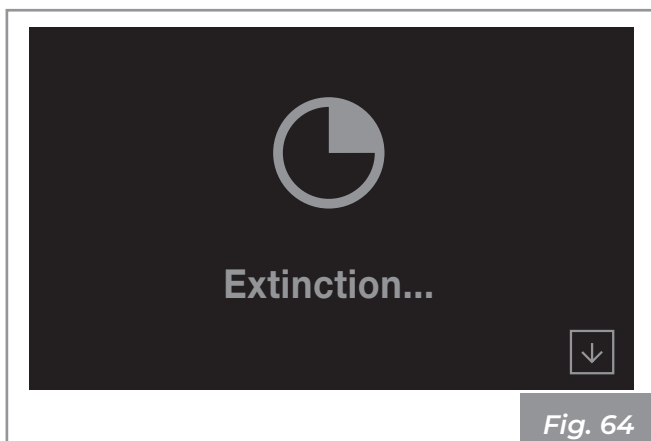

Fig. 64

Si la température est encore élevée, une phase de refroidissement démarre :

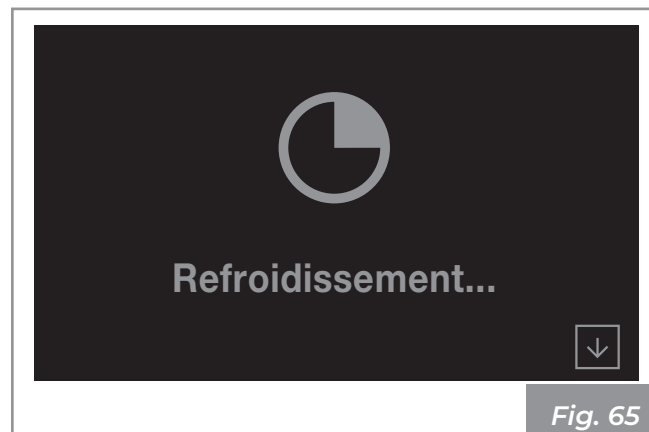

Fig. 65



Indication : Pour effectuer un nouvel allumage, il est conseillé d'attendre que l'appareil ait complètement refroidi.



Danger : Il est recommandé d'éteindre l'appareil en suivant scrupuleusement les indications données ci-dessus. Il est interdit d'éteindre l'appareil en coupant l'alimentation électrique.

4.4 Rallumage après une coupure de courant

En cas de coupure de courant, l'appareil se rallumera automatiquement, et vérifiera les conditions de sécurité, au retour de l'alimentation.

4.5 Fonctionnement avec thermostat d'ambiance

Quand l'appareil est commandé par un thermostat (ou un programmeur de chauffage) externe, l'installateur doit avoir défini la **configuration 1**.

Ici, l'appareil s'éteint quand le thermostat externe est satisfait (circuit ouvert).

L'appareil se rallume automatiquement quand la température descend en dessous de la valeur définie sur le thermostat externe (circuit fermé).



Indication : Au premier allumage, ou si l'arrêt a directement été effectué par l'appareil, il faudra allumer l'appareil directement sur le panneau de commande.

4.6 Fonctionnement avec une sonde d'ambiance intégrée dans le poêle

L'appareil peut être allumé/éteint manuellement ou en mode programmé.

L'appareil module la puissance en fonction de la température ambiante lue par la sonde intégrée (il tente de maintenir la température souhaitée en consommant le moins possible).

Si l'utilisateur a activé la fonction « Mode écologique », au lieu de moduler, l'appareil s'éteint une fois que la température définie est atteinte, et se rallume quand la température ambiante descend en dessous du delta défini (voir paragraphe « 3.1.4 Fonction « Mode écologique » »).

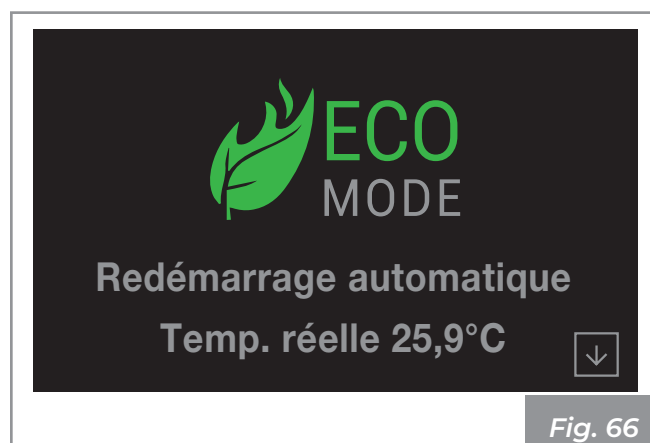

Fig. 66

5 FONCTIONS DISPONIBLES

5.1 Paramètre chrono

Il est possible de configurer, d'activer et d'attribuer aux différents jours de la semaine, les programmes personnalisés pour l'allumage et/ou l'extinction automatique de l'appareil.

Il est possible de configurer jusqu'à 6 programmes personnalisés.

Pour chaque programme, on peut programmer l'heure d'allumage, l'heure d'arrêt et la température désirée.

Il est possible d'attribuer à chaque jour de la semaine jusqu'à 3 programmes.

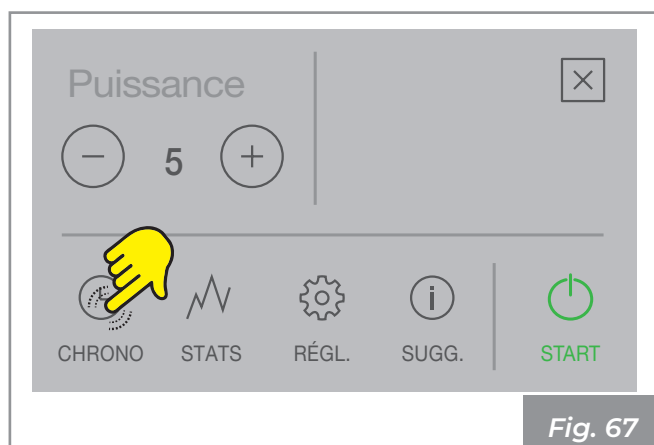

Fig. 67

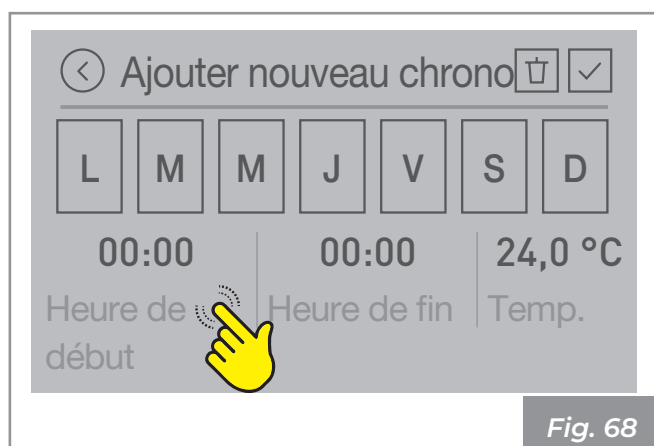

Fig. 68

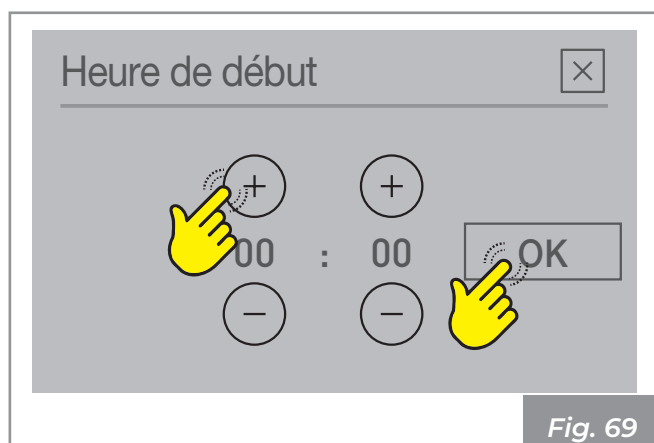

Fig. 69

Exemple de Chrono configuré

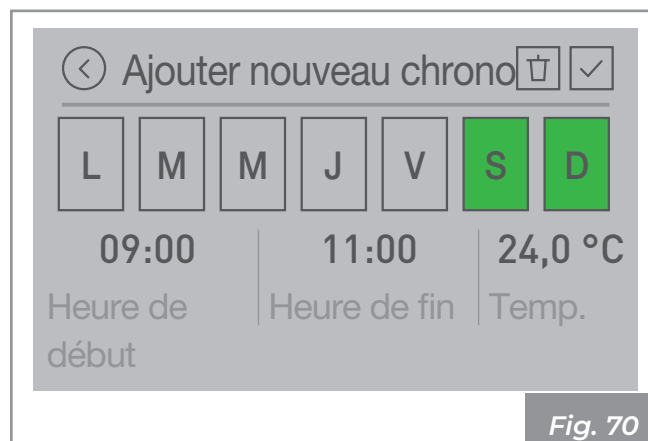

Fig. 70



Indication : La température pouvant être définie sur le chrono dépend du type de configuration de l'appareil. Pour plus de précisions, voir le paragraphe « 1.4 Page initiale et température de consigne ».

5.1.1 Activation/désactivation du chrono

Sélectionner ON pour activer le chrono ou OFF pour le désactiver.

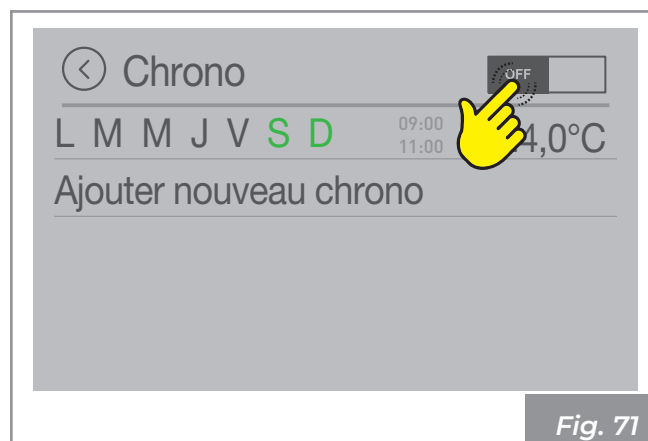

Fig. 71

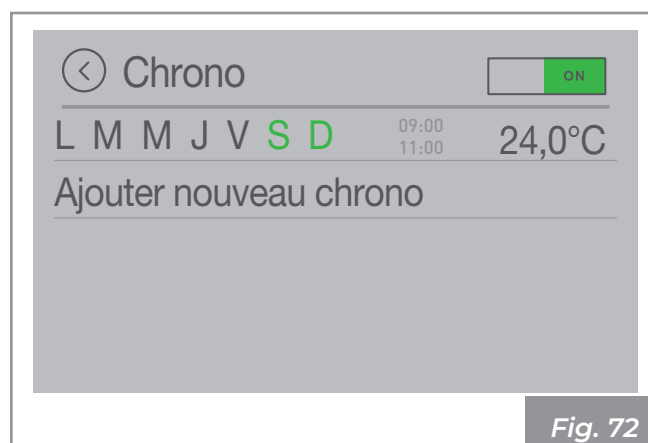

Fig. 72

L'appareil s'allumera à 9h00 et s'éteindra à 11h00 le samedi et le dimanche

5.2 Stats

Il est possible d'afficher les statistiques d'utilisation de l'appareil.

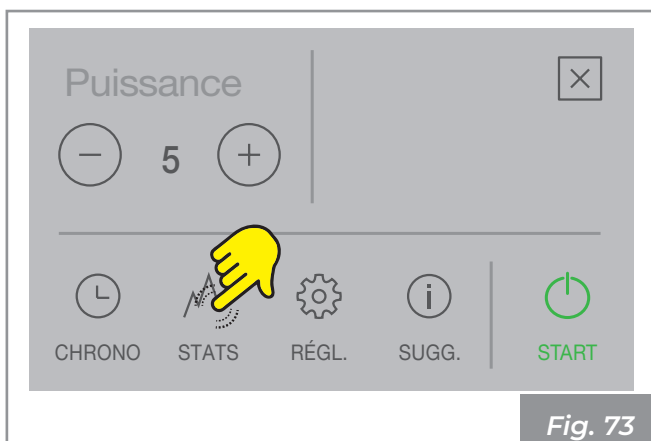

Fig. 73



Fig. 74



Fig. 75

Exemple de statistique

En sélectionnant « Aujourd'hui », il est possible de voir :

- les kilogrammes de pellet utilisés
- le temps d'allumage
- la puissance moyenne produite
- la température ambiante moyenne

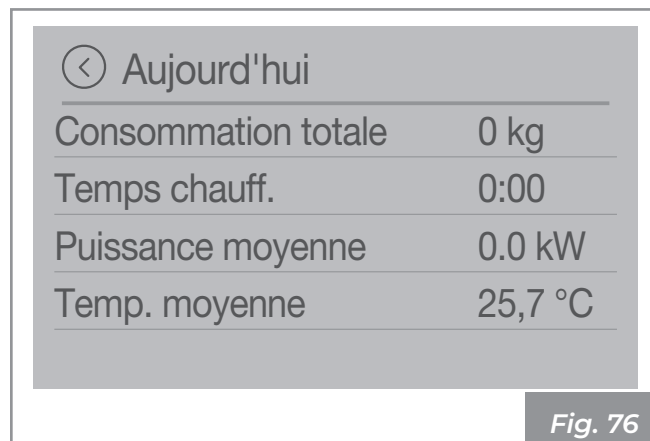



Fig. 76

Supprimer statistiques

Appuyer sur l'icône  pour supprimer les statistiques :

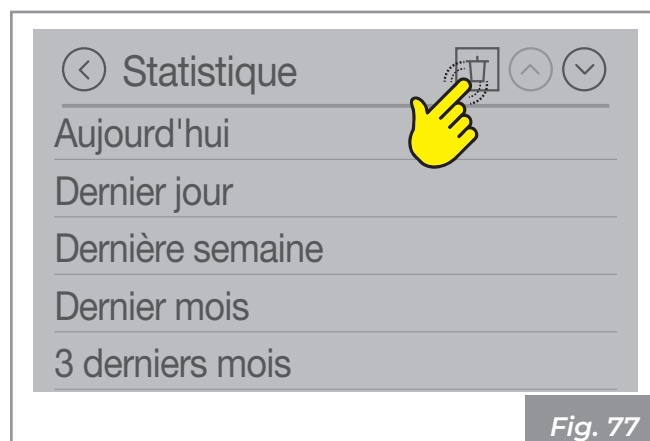

Fig. 77



Fig. 78

5.3 Suggestions de fonctionnement

Ce menu sert à fournir de simples conseils sur le bon fonctionnement du produit.

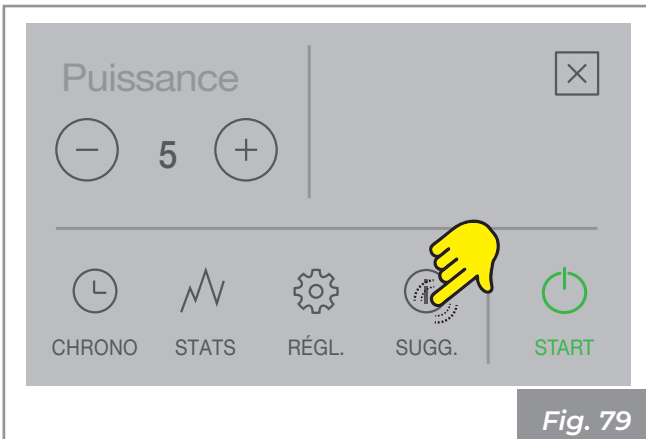

Fig. 79

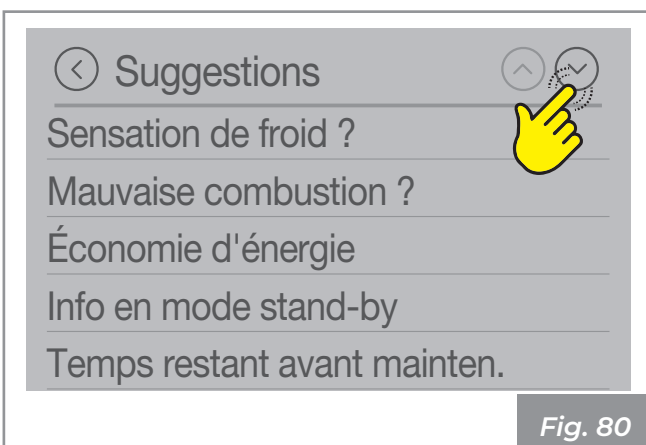

Fig. 80

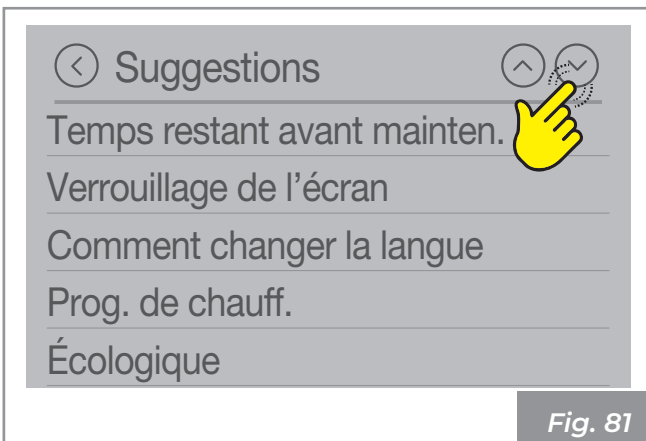

Fig. 81

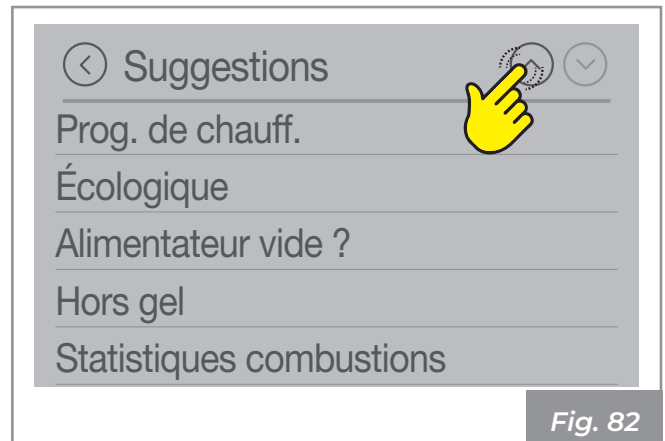

Fig. 82

6 ANOMALIES ET SOLUTIONS POSSIBLES

En cas d'anomalie de fonctionnement, une alarme sonore (bip) se déclenche et l'écran affiche la cause possible avec un code numérique d'erreur.

Les erreurs sont divisées en :

- **Alarmes** **E** : erreurs bloquantes. L'appareil s'éteint. La cause du message d'alarme doit être résolue avant de rallumer l'appareil.
- **Avertissements** **!** : simples avertissements qui ne bloquent pas le fonctionnement de l'appareil (mais le limitent dans certains cas). Ils se réinitialisent automatiquement une fois que la cause les ayant générés est éliminée ou qu'elle a disparu.

Exemple d'affichage Alarme E102 :

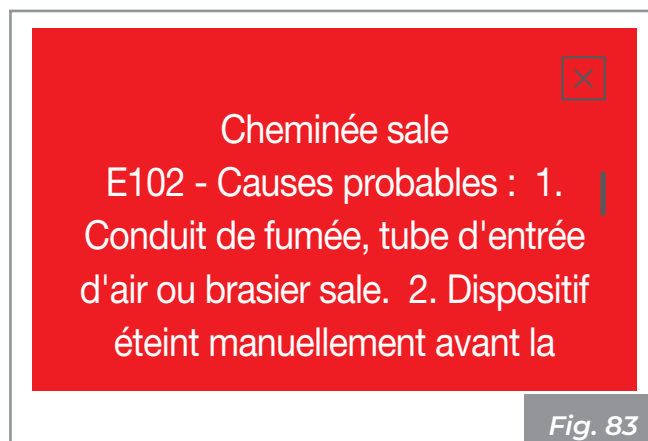

Fig. 83

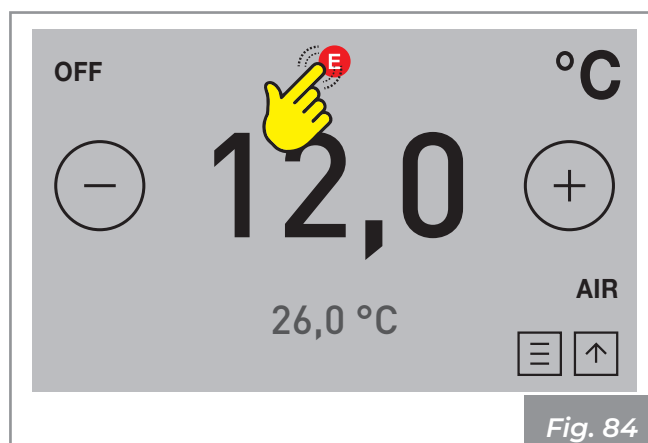

Fig. 84

6.1 Description des alarmes

Code alarme	Description	Causes possibles
E002	IR erreur de communication	Capteur infrarouge ne fonctionne pas. Appeler le service.
E004	MB erreur de communication	Erreur de communication MB
E101	Erreur de feu	Échec de l'allumage
E102	Cheminée sale	1. Nettoyage nécessaire de la cheminée, du tube d'entrée d'air ou du braséro. 2. Arrêt manuel du dispositif avant la détection de flamme.
E104	Grille bloquée	Vider et nettoyer le braséro. Réinitialiser l'erreur.
E105	Erreur NTC2	Dysfonctionnement ou déconnexion du capteur connecté à T02. Appeler le service.
E106	Erreur NTC3	Dysfonctionnement ou déconnexion du capteur connecté à T05. Appeler le service.
E108	Erreur interrupteur de sécurité	Interrupteur connecté à I01 ouvert. Réinitialiser l'alarme et redémarrer l'appareil. Si l'erreur persiste, appeler le service.
E109	Erreur de pression	Capteur de pression ou de sécurité thermique ouvert. Réinitialiser l'alarme et redémarrer l'appareil. Si l'erreur persiste, appeler le service.

Code alarme	Description	Causes possibles
E110	NTC1	Dysfonctionnement ou déconnexion du capteur connecté à T01. Appeler le service.
E111	TC1	Dysfonctionnement ou déconnexion du capteur connecté à T03. Appeler le service.
E113	Surtempérature gaz	Surtempérature Fumées. Nettoyer échangeur ou cheminée.
E114	Échec de l'allumage	Délai d'allumage expiré (vider le brazéro et redémarrer l'appareil) ou réservoir de vide (remplir le réservoir).
E115	Erreur générale	Contactez le service.

6.2 Réinitialisation des alarmes



En cas d'alarme, l'écran devient rouge et un signal sonore est émis (bip).

L'écran affiche le code d'alarme et la cause possible.

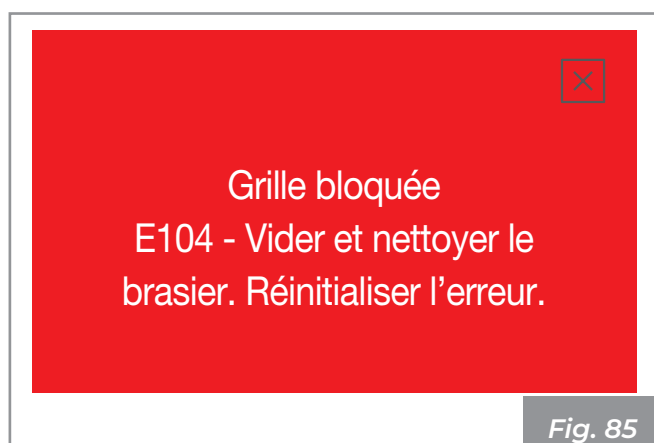
L'appareil s'éteint.



Danger: En cas d'alarme « E108 » ou « E109 », il faut, avant de réinitialiser l'alarme, réactiver le thermostat à réarmement manuel situé au dos de l'appareil (à effectuer par le Centre d'Assistance Technique). À ce point, il est possible de procéder à un autre allumage.

En fermant la page en appuyant sur  l'alarme ne se réinitialise par et l'icône  reste.

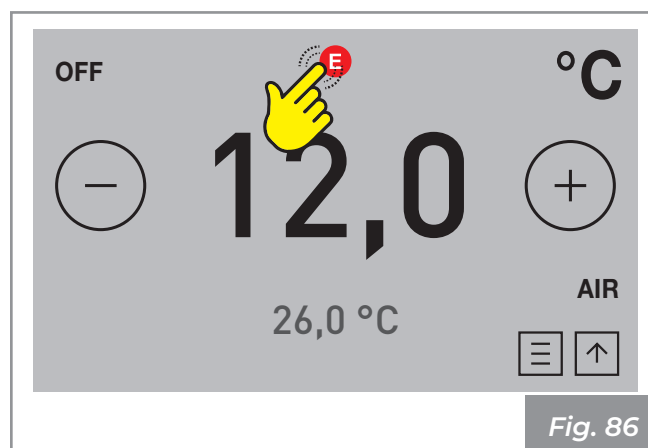

Pour revoir la description de l'alarme, appuyer sur l'icône .

Avant de procéder à un nouvel allumage, vérifier que :

- l'appareil a refroidi ;
- la cause du message d'alarme est résolue ;
- le brazéro est propre et sans aucun résidu de cendre ou pellet ;
- le brazéro est correctement placé dans son logement ;
- les portes du foyer et du réservoir sont parfaitement fermées.

6.3 Description des avertissements

Code avertissement	Description	Causes possibles - solutions
A001	Niveau combustible bas	Avertissement sur le niveau de combustible, remplir le réservoir.
A002	Entretien	Temps de fonctionnement expiré, contacter le service d'assistance pour l'entretien.
A004	Batterie déchargée	Batterie déchargée, contacter le service pour son remplacement.
A005	Capteur vitesse	Dysfonctionnement du capteur de vitesse, contacter le service d'assistance.
A007	Capteur de pression/flux d'air	Mode de fonctionnement alternatif, fonction limitée. Dysfonctionnement du capteur flux d'air, contacter le service d'assistance.

6.4 Réinitialisation des avertissements

En cas d'avertissement, l'écran devient jaune et un signal sonore est émis (bip). L'écran affiche le code d'avertissement et la cause possible.



Pour revoir la description de l'avertissement, appuyer sur l'icône . Pour réinitialiser l'avertissement, le problème doit être résolu.



Fig. 87



Attention : En cas d'avertissement, l'appareil fonctionne encore (les fonctions sont limitées dans certains cas).

En fermant la page en appuyant sur  l'avertissement ne se réinitialise pas et l'icône  reste.

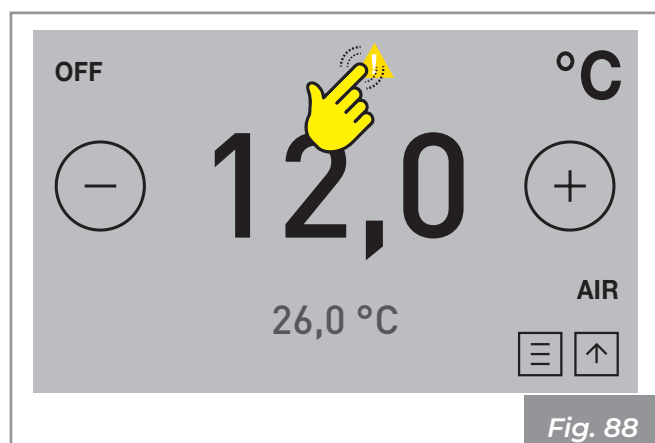

Fig. 88

ÍNDICE

1	PANEL DE MANDOS	107
1.1	Descripción	107
1.2	Descripción general de los iconos	107
1.3	Árbol de navegación	108
1.4	Pantalla de inicio y programación temperatura	109
2	OPERACIONES PRELIMINARES	111
2.1	Carga de pellet	111
2.2	Alimentación eléctrica	111
3	MENÚ PARÁMETROS	112
3.1	Parámetros	112
3.1.1	Parámetro "Tiempo"	113
3.1.2	Parámetro "Fecha"	113
3.1.3	Función "Combustible"	113
3.1.4	Función "Modo ecológico"	114
3.1.5	Función "Anti-hielo"	114
3.1.6	Pantalla	115
3.1.7	Función "Limpieza"	116
3.1.8	Ajuste "Unidad de temperatura"	116
3.1.9	Ajuste "Altavoz"	117
3.1.10	Función "Tiempo para revisión"	117
3.1.11	Menú Instalador	117
3.1.12	Menú de servicio	118
3.1.13	Función "Bloqueo de pantalla"	118
3.1.14	Idioma	119
3.1.15	Informaciones	119

4 USO	120
4.1 Encendido	120
4.1.1 Modificación de la temperatura ambiente	121
4.1.2 Modificación de la potencia	121
4.2 Modificación de los parámetros	121
4.3 Apagado	122
4.4 Reencendido luego de black-out	122
4.5 Funcionamiento con termostato ambiente	123
4.6 Funcionamiento con sonda ambiente incorporada en la estufa	123
5 FUNCIONES DISPONIBLES	124
5.1 Ajuste temporizador	124
5.1.1 Habilitación/deshabilitación del temporizador	124
5.2 Estadísticas	125
5.3 Avisos de funcionamiento	126
6 AVERÍAS Y SOLUCIONES POSIBLES	127
6.1 Descripción de alarmas	127
6.2 Reset de alarmas	128
6.3 Descripción avisos	129
6.4 Reset avisos	129

SÍMBOLOS UTILIZADOS EN EL MANUAL Y SU SIGNIFICADO



Indicación: Indica información particular.



Atención: Indica operaciones particularmente importantes y delicadas.



Peligro: Indica acciones que, cuando no se realizan correctamente, podrían causar accidentes de tipo genérico, averías o daños materiales en el aparato.

1 PANEL DE MANDOS

1.1 Descripción

El panel de mandos está compuesto por:

- 1) Receptor IR (infrarrojos)
- 2) Sensor luz ambiente
- 3) Pantalla táctil
- 4) Altavoces
- 5) Conector RJ11

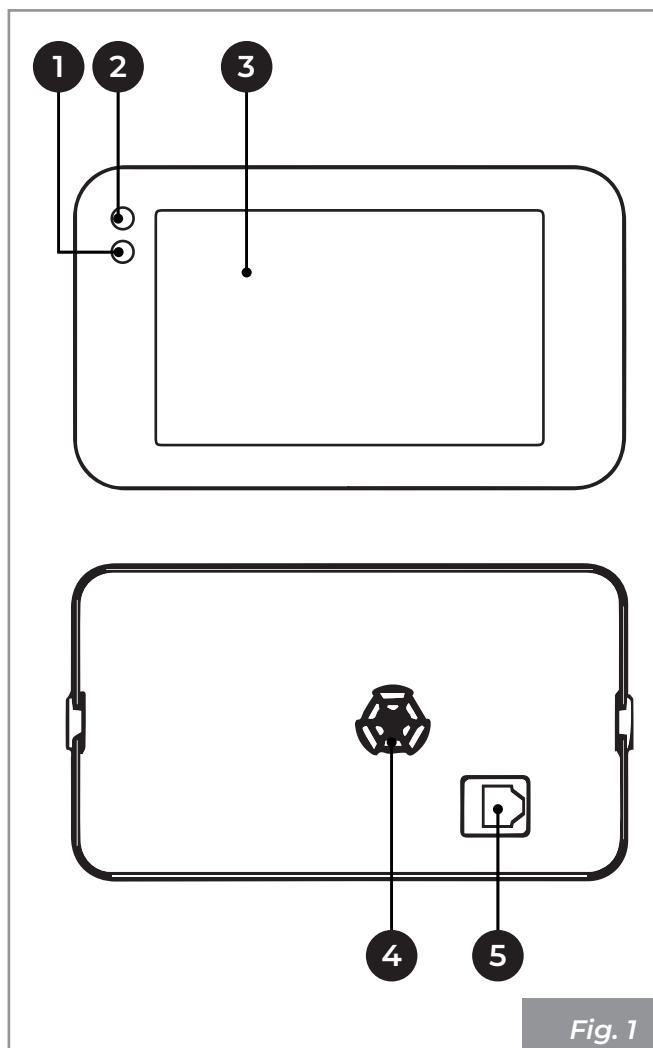

Indicación: La pantalla es de tipo táctil, por tanto no requiere presión para ser activada, es suficiente rozar su superficie.

1.2 Descripción general de los iconos

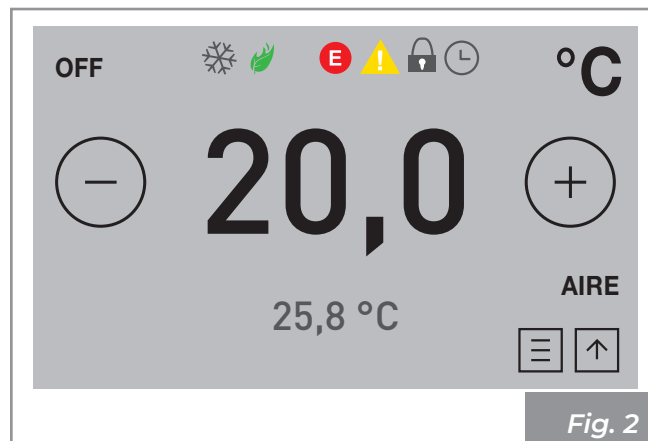

Icono	Descripción
	Alarma
	Aviso
	Función modo ecológico activa
	Menú principal
	Encendido aparato
	Temporizador activo
	Función "Anti-hielo" activa
	Bloqueo de pantalla
OFF	Indicación aparato apagado
20.0	Temperatura programada
25.8	Temperatura detectada por la sonda

1.3 Árbol de navegación

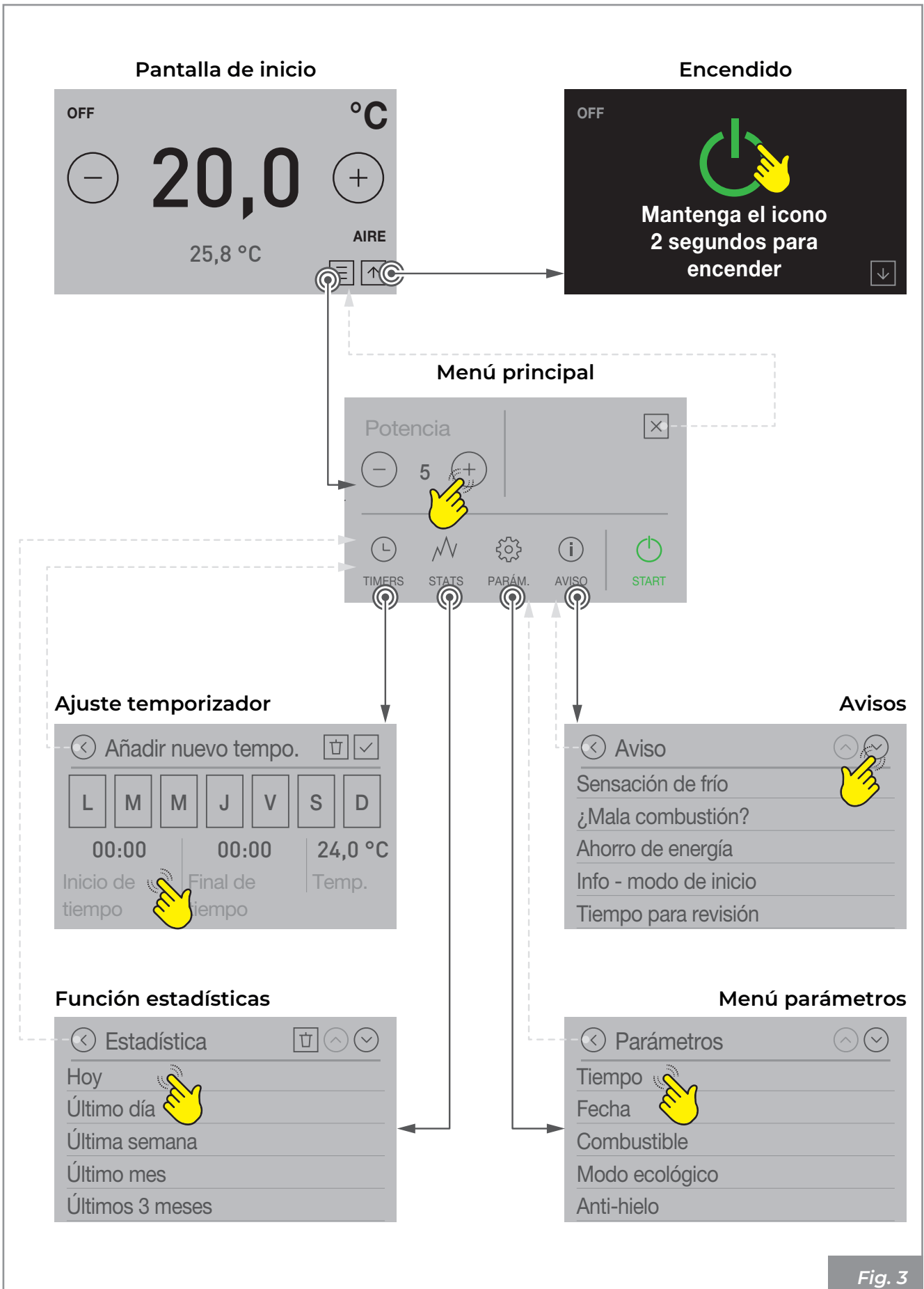

Fig. 3

1.4 Pantalla de inicio y programación temperatura

Dependiendo de la configuración de instalación del aparato, se visualizan distintas pantallas de inicio y diferentes valores de temperatura.

Configuración 1 - Termostato externo

Pantalla de inicio

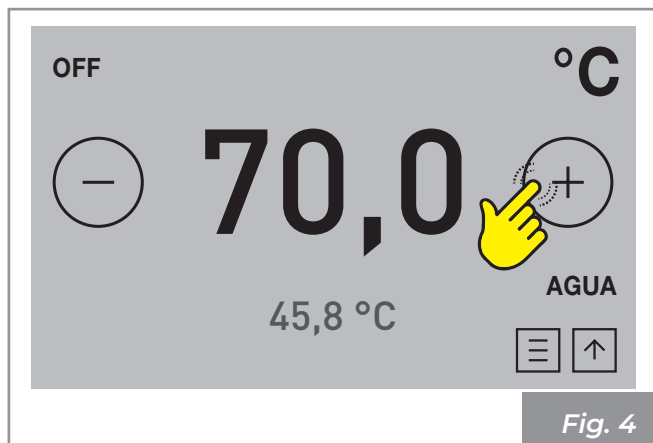

Fig. 4

Esta pantalla se refiere a la temperatura de impulsión del agua caliente de la caldera.

Pulse los iconos \oplus o \ominus para cambiar la temperatura de impulsión que desea (dígitos grandes). Los valores que se pueden programar están comprendidos entre 45°C y 80°C.

Los dígitos pequeños muestran la temperatura actual detectada por la sonda de impulsión

Pulse "**AGUA**". Se pasa a la siguiente visualización:

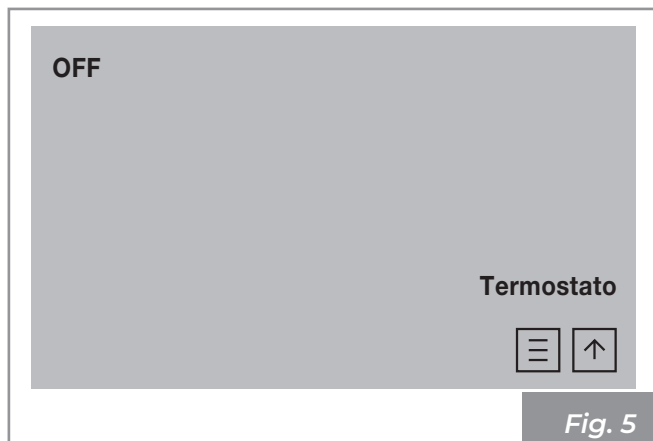

Fig. 5

Pulse "**Termostato**" para volver a la pantalla anterior.

Configuración 2 - Sonda ambiente

Pantalla de inicio

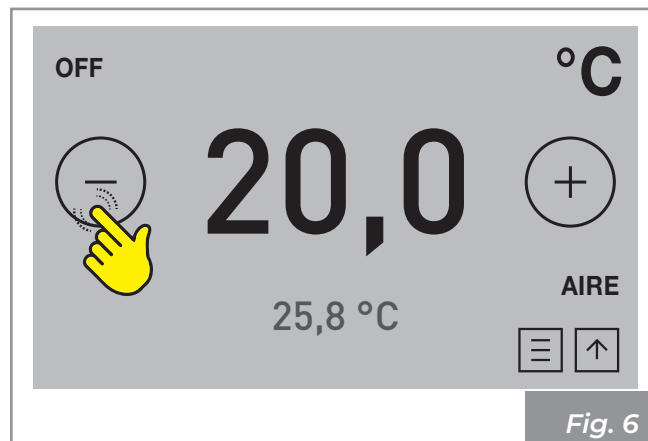

Fig. 6

Esta pantalla se refiere a la temperatura aire.

Pulse los iconos \oplus o \ominus para cambiar la temperatura aire que se desea alcanzar (dígitos grandes). Los valores que se pueden programar están comprendidos entre 10°C y 40°C.

Los dígitos pequeños muestran la temperatura ambiente detectada por una sonda ubicada en el aparato

Pulse "**AIRE**". Se pasa a la visualización de la temperatura de impulsión del agua caliente de la caldera:

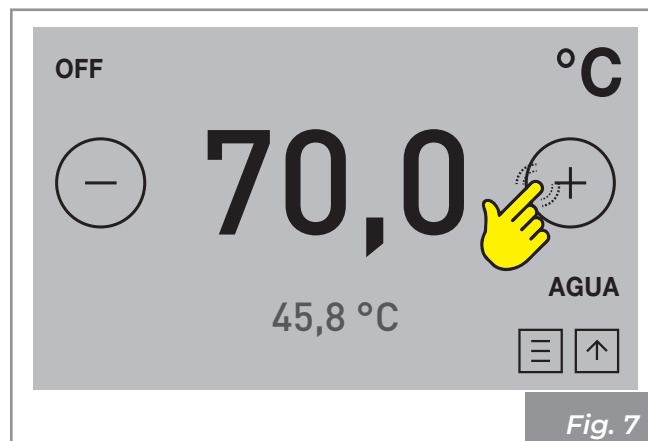
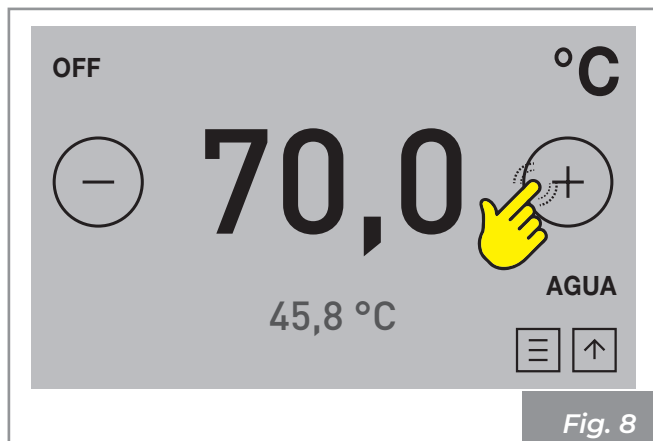

Fig. 7

Pulse los iconos \oplus o \ominus para cambiar la temperatura de impulsión que desea (dígitos grandes). Los valores que se pueden programar están comprendidos entre 45°C y 80°C.

Los dígitos pequeños muestran la temperatura actual detectada por la sonda de impulsión

Configuración 3/4 - Acumulador con/sin serpentín*Pantalla de inicio*

Esta pantalla se refiere a la temperatura del agua caliente dentro del acumulador.

Pulse los iconos \oplus o \ominus para cambiar la temperatura que se desea mantener dentro del acumulador (dígitos grandes)

Los valores que se pueden programar están comprendidos entre 45°C y 80°C.

Los dígitos pequeños muestran la temperatura actual detectada por la sonda presente en el acumulador.

2 OPERACIONES PRELIMINARES

2.1 Carga de pellet

La primera operación para realizar antes de encender el producto es la de llenar el depósito de combustible (pellet) utilizando preferiblemente una paleta adecuada.

No vaciar el saco directamente en el depósito para evitar cargar serrín u otros elementos extraños que podrían comprometer el buen funcionamiento del aparato y para evitar dispersar el pellet fuera del depósito.

Indicación: Asegurarse de cerrar bien la tapa del depósito después de haber realizado la operación de carga del pellet. Un interruptor de seguridad "IS" (sólo para los modelos donde está previsto) comprueba el cierre correcto y activa el estado de alarma del aparato cuando se deja abierta la tapa por más de un minuto estando el aparato funcionando.

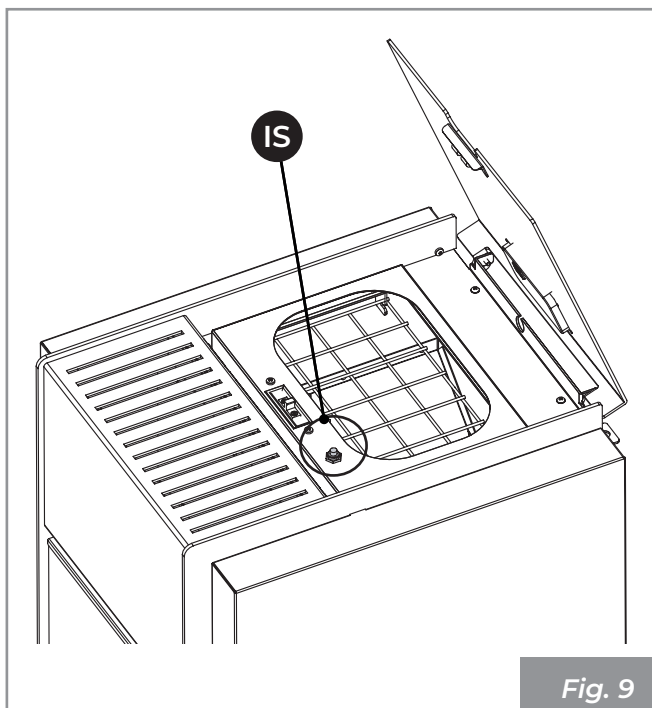

Fig. 9

2.2 Alimentación eléctrica

Conecte el aparato a la red eléctrica, coloque en la posición "I" el interruptor de encendido, ubicado en la parte trasera del aparato.



Fig. 10

Si la conexión se realiza correctamente el aparato emite una serie de señales acústicas intermitentes y la pantalla se enciende.



Atención: Para largos períodos de inactividad, se recomienda posicionar el interruptor ubicado en la parte trasera del aparato en la posición OFF (O).



Indicación: Asegúrese de no tocar el panel de mando cuando se están alimentando el aparato.

Tras alimentar el aparato aparece el logotipo de inicio.



Fig. 11

Al cabo de unos segundos aparece la pantalla de inicio:

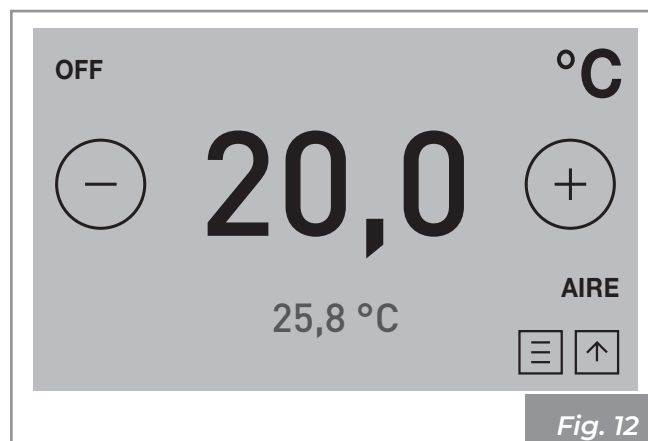

Fig. 12

3 MENÚ PARÁMETROS

3.1 Parámetros

Pulse el icono  para acceder al menú parámetros.

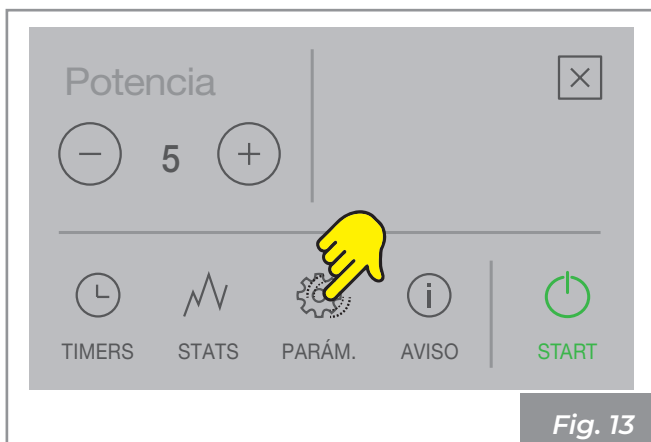

Fig. 13

Pulse \uparrow y \downarrow para desplazarse por la lista de parámetros.

Pulse el parámetro que desea para abrir la pantalla de cambio del parámetro.

Normalmente los ajustes del parámetro se cambian pulsando los iconos \oplus o \ominus .

Pulse para confirmar o cerrar la pantalla de cambio sin guardar.

Lista de parámetros

Parámetro	Descripción	Valores programables	Valores por defecto
Tiempo	Ajuste tiempo	Fecha y tiempo programados correctamente	
Fecha	Ajuste tiempo		
Combustible	Es posible programar 3 diferentes configuraciones de combustión	1 ... 3	1
Modo ecológico *	Activa el modo ecológico	ON; OFF	<input type="checkbox"/> ON
Anti-hielo *	Temperatura mínima por debajo de la cual el aparato se enciende	OFF; 3 ... 20 °C (OFF; 3 ... 50 °C)	OFF
Opciones pantalla	Configura el nivel de brillo y la información de la pantalla en stand-by		
Unidad de temp.	Unidad de medida de la temperatura	°C ...°F	°C
Altavoz	Programa el nivel de volumen	OFF; 1 ... 5	2
Tiempo para revisión	Muestra las horas que faltan para el mantenimiento periódico.		2016 h
Menú Instalador	Modifica/Visualiza la configuración del aparato	PWD: "54"	
Menú de servicio	Menú de competencia del centro de asistencia		
Bloqueo de pantalla	Configura la modalidad de bloqueo de las teclas	OFF; LOW; HI	OFF
Idioma	Programa el idioma de la pantalla:	English Italiano Deutsch Español Français Português Bosanski jezik Slovenscina Swedish Dutch Romana	English
Info	Muestra la información de sistema		

(*) Parámetro disponible sólo en algunas configuraciones

3.1.1 Parámetro "Tiempo"

Para configurar el tiempo:

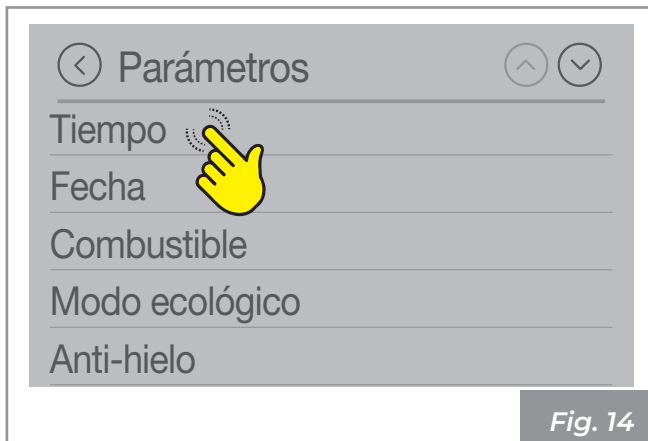

Fig. 14

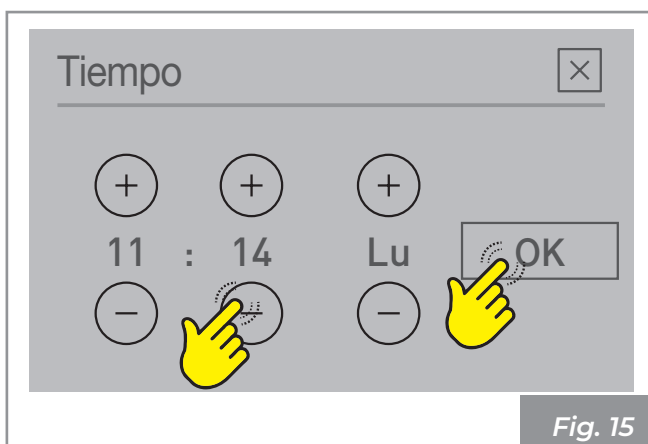

Fig. 15

3.1.2 Parámetro "Fecha"

Para configurar la fecha:



Fig. 16

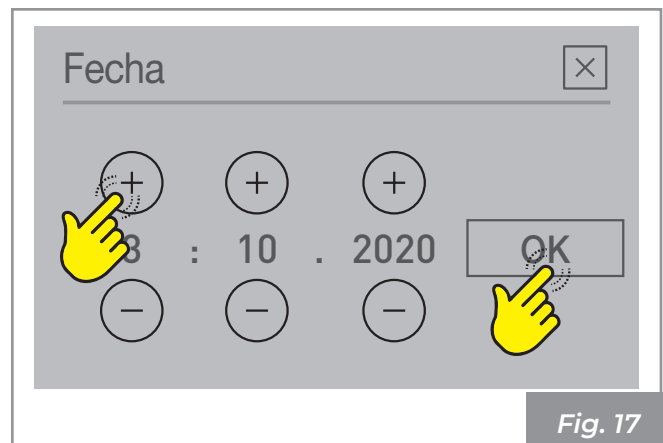

Fig. 17

3.1.3 Función "Combustible"

Una combustión ideal depende de diferentes factores (tipo de instalación, condiciones de funcionamiento y de mantenimiento, tipo de pellet, etc...) En líneas generales, si al final de la combustión, en el brasero permanecen muchos residuos, se aconseja modificar las configuraciones de combustión (aumentando el valor) hasta encontrar la solución más satisfactoria.

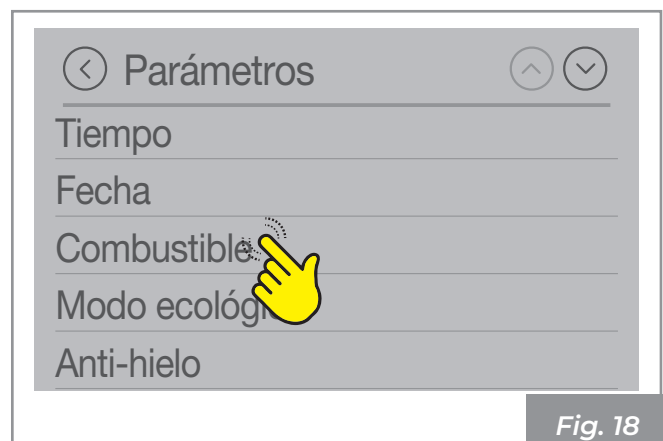

Fig. 18

Optimización de la combustión:

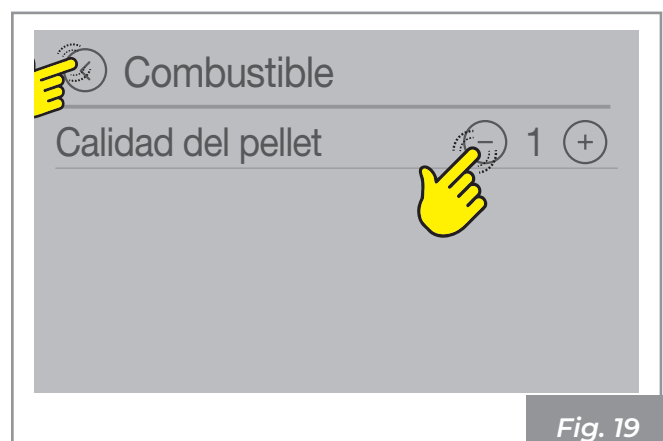

Fig. 19

Los valores programables están comprendidos entre 1 y 3.

- 1) Pellet de alta calidad (En Plus)
- 2) Pellet de calidad media
- 3) Pellet de calidad baja

3.1.4 Función "Modo ecológico"

Esta función está disponible sólo en la configuración 2.

Habilitando esta función se hace que el aparato, al alcanzar la temperatura deseada en el ambiente, se apague.

Si esta función no está habilitada, el aparato ajusta su funcionamiento sin apagarse.

Para activar/desactivar esta función:

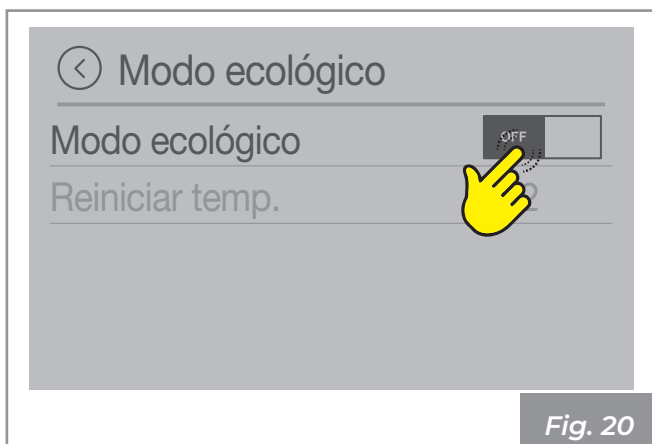

Fig. 20

	Función "Modo ecológico" desactivada
	Función "Modo ecológico" activa

Cuando se activa la función "Modo ecológico" está disponible la función "Reiniciar temp." que indica la cantidad de grados por debajo de la temperatura configurada, más allá de la cual el aparato se reinicia de modo automático.

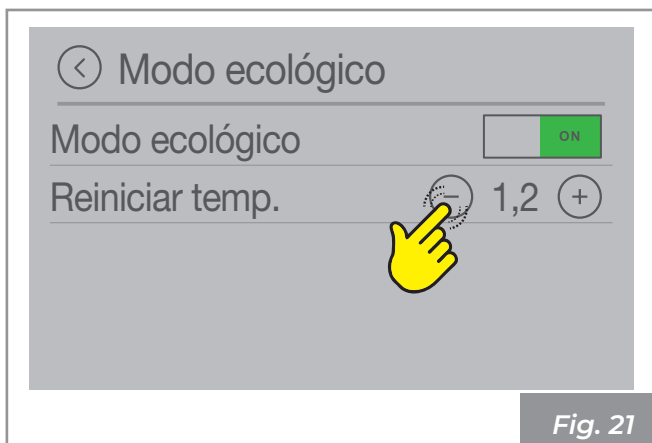

Fig. 21

Ejemplo: si el aparato está programado para apagarse a 20°C (función "Modo ecológico" activa) y se configura un valor de "Reiniciar temp." de 4°C, el aparato se volverá a encender cuando detecta una temperatura inferior o igual a 16°C.

Los valores programables están comprendidos entre 0,5 y 5,0 °C.

3.1.5 Función "Anti-hielo"

Esta función está disponible sólo en las configuraciones 2, 3 y 4.

Es posible configurar una temperatura mínima por debajo de la cual el aparato se enciende (fuera de las franjas horarias configuradas, y únicamente cuando el temporizador está activado).

Para modificar el valor de la temperatura de "anti-hielo":

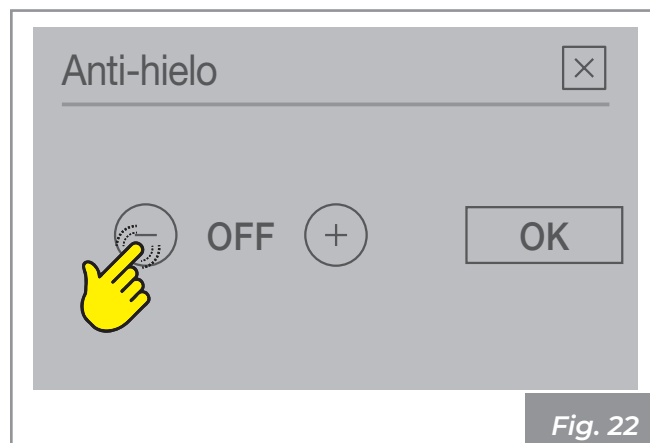

Fig. 22

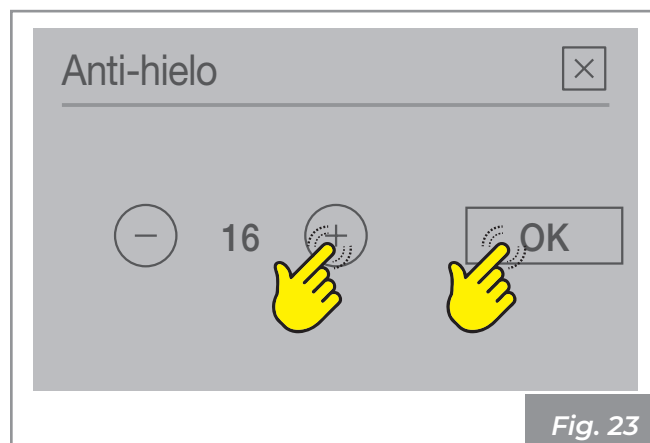

Fig. 23

Los valores programables:
 (OFF; 3 ... 20°C) para la configuración 2
 (OFF; 3 ... 50°C) para las configuraciones 3 y 4

3.1.6 Pantalla

Pulse "Opciones pantalla" para modificar las características de visualización de la pantalla.

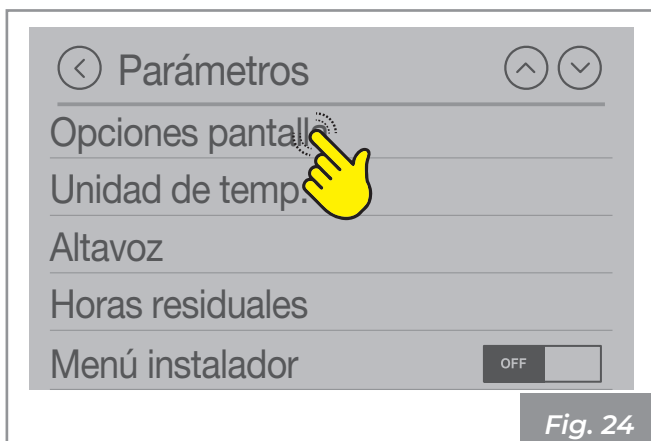

Fig. 24

Nivel de brillo de la pantalla

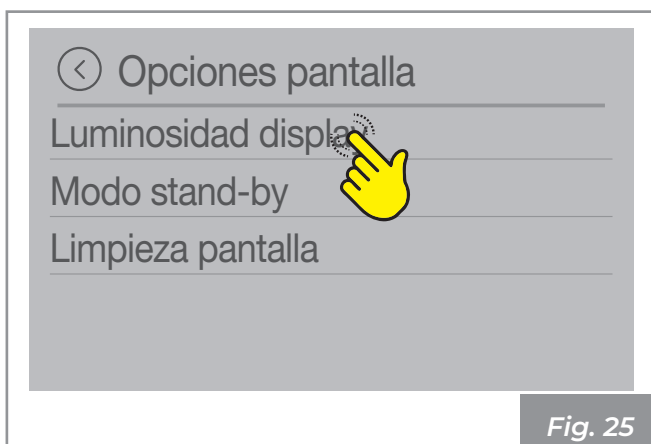

Fig. 25

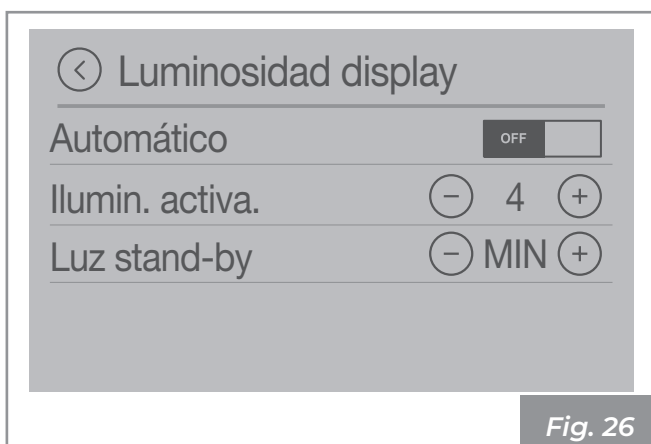

Fig. 26

Brillo durante el uso de la pantalla: de 0 a 100% de brillo

Los valores programables: MÍN - 2 - 3 - 4 - MÁX;

Brillo de la pantalla cuando se activa el modo stand-by: de 0 a 50% de brillo

- OFF
- MÍN - 2 - 3 - 4 - MÁX

En la posición OFF, la pantalla se vuelve negra cuando no se utiliza por 60 segundos, se reactiva tocándola.

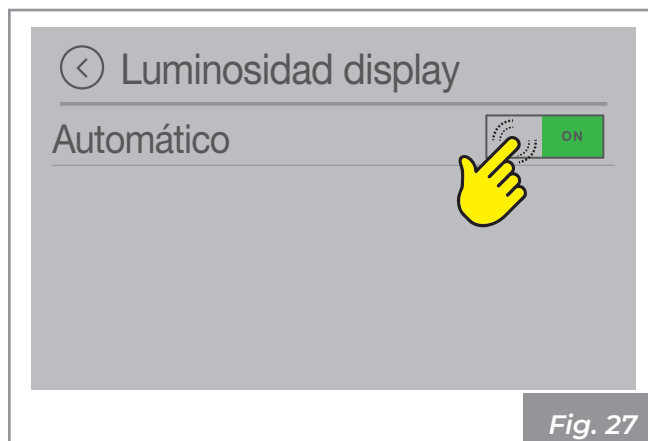

Fig. 27

Automático: se ajusta en función del sensor de brillo

Pantalla en "Modo stand-by"

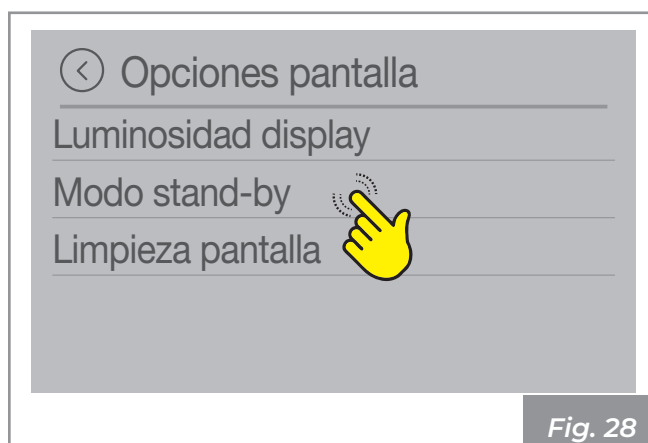

Fig. 28

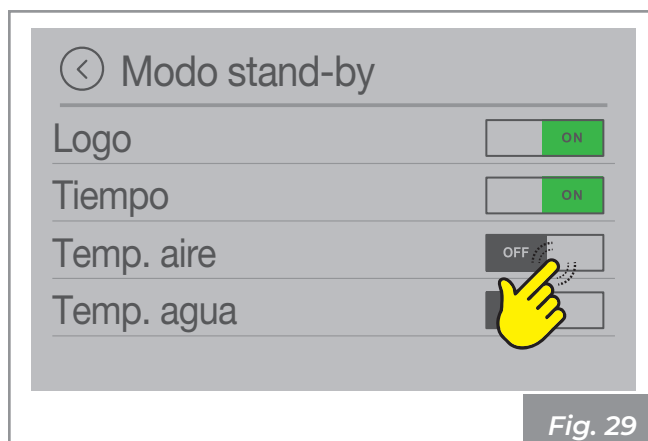

Fig. 29

Es posible elegir qué se quiere visualizar cuando la pantalla está en modo stand-by:

- Logo
- Tiempo
- Temperatura aire
- Temperatura del agua

Ejemplo de pantallas que se alternan cíclicamente cuando la pantalla está en modo stand-by:

Tiempo y fecha



Fig. 30

Temperatura aire

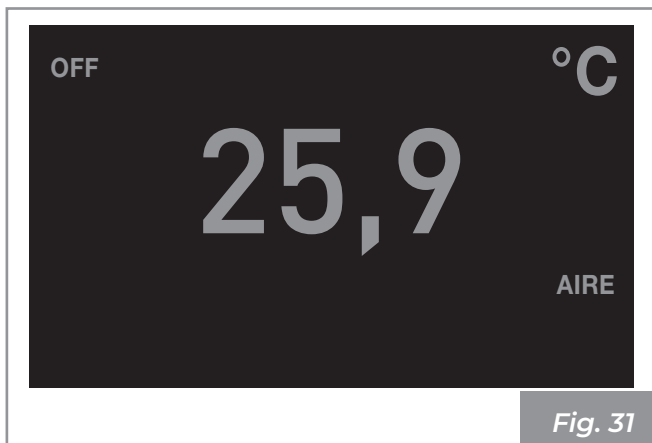

Fig. 31

3.1.7 Función "Limpieza"

Ajuste para realizar la limpieza de la pantalla



Fig. 32

Pulse "START": comienza una cuenta atrás, la señal acústica BIP indica que la pantalla está inactiva y se puede realizar su limpieza sin interferir con sus funciones.

Al final de la cuenta atrás la pantalla táctil vuelve a estar activa.



Fig. 33

3.1.8 Ajuste "Unidad de temperatura"

Para modificar la unidad de medida de la temperatura:

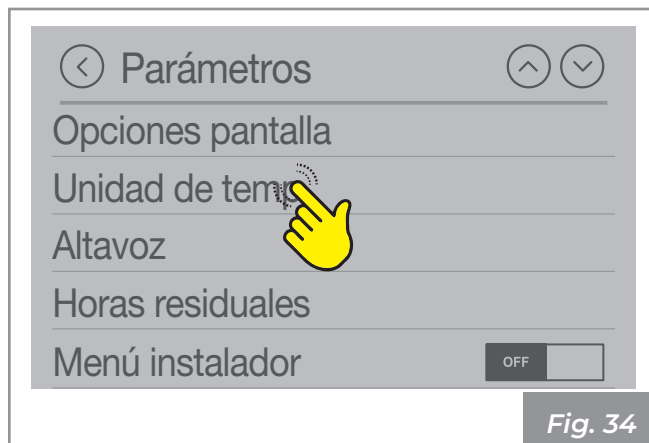

Fig. 34

Para cambiar de °C a °F pulse ⊕ o ⊖. Pulse para confirmar.



Fig. 35

3.1.9 Ajuste "Altavoz"

Para modificar el nivel de intensidad del altavoz:

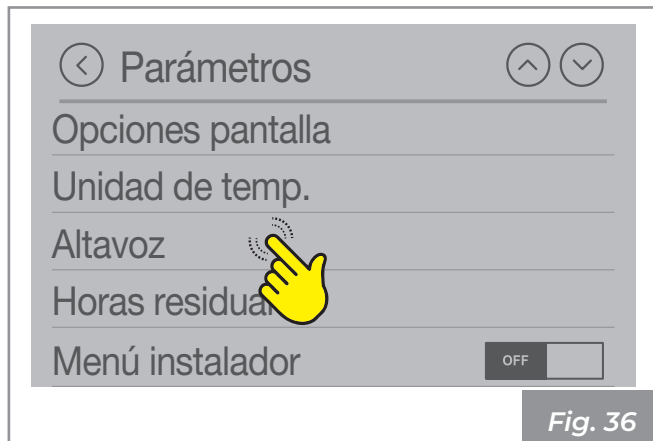

Fig. 36

Pulse \oplus y \ominus para configurar el nivel de volumen deseado (OFF, 1 ... 5).

Pulse **OK** para confirmar.



Fig. 37

3.1.10 Función "Tiempo para revisión"

Indica cuánto tiempo falta para el siguiente mantenimiento periódico.

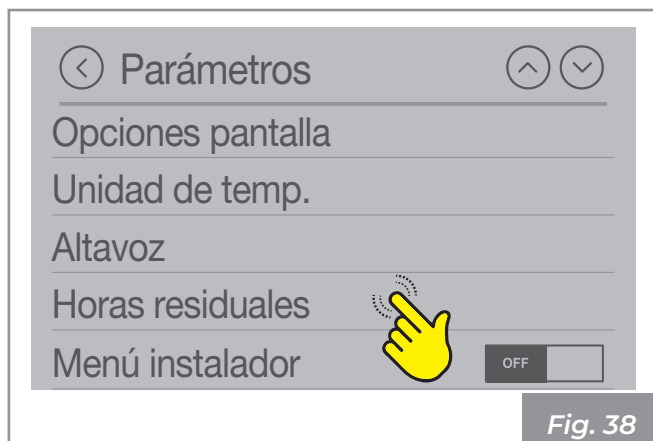

Fig. 38

Muestra las horas que faltan para el mantenimiento

periódico.

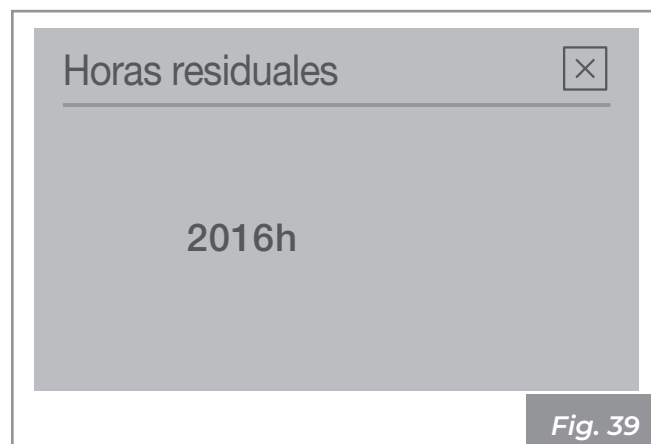

Fig. 39

3.1.11 Menú Instalador



Peligro: Los submenús están protegidos por contraseña y son de uso exclusivo para el servicio técnico.

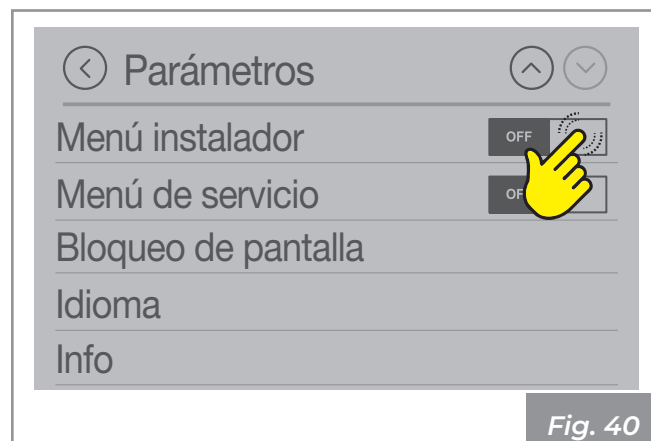

Fig. 40

Pulse **ON**: aparece la contraseña, configure **54** y pulse **OK** para confirmar.



Fig. 41

Pulse "**Configuraciones**".

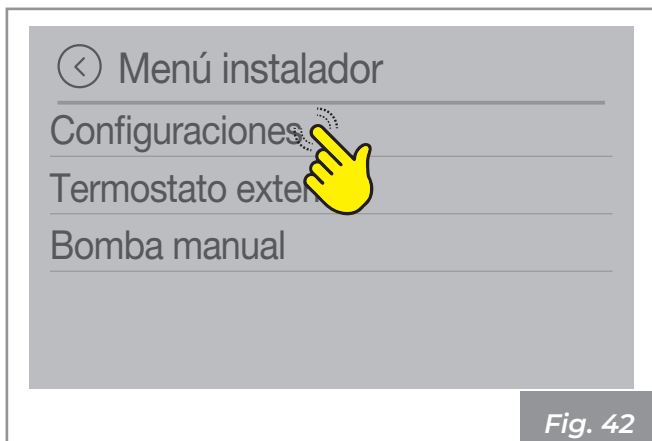

Fig. 42

Se visualizan las configuraciones posibles del aparato. La configuración actualmente configurada resulta en ON, todas las demás en OFF.

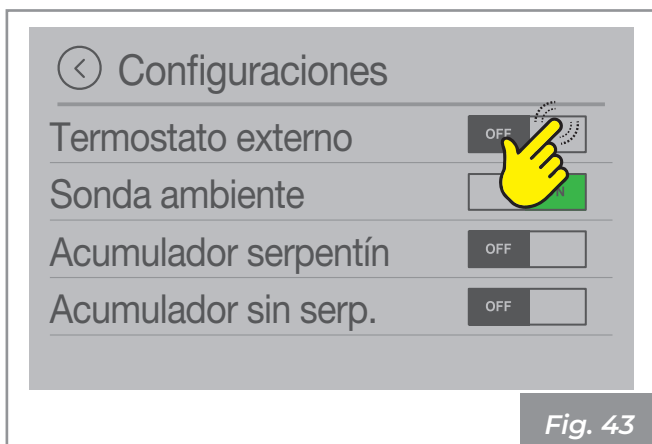

Fig. 43

Configuración	Descripción	Por defecto
1	Termostato externo	OFF
2	Sonda ambiente	ON
3	Acumulador con serpentín	OFF
4	Acumulador sin serpentín	OFF

Consulte la configuración del sistema en el manual de instalación.

3.1.12 Menú de servicio



Peligro: Los submenús están protegidos por contraseña y son de uso exclusivo para el servicio técnico.

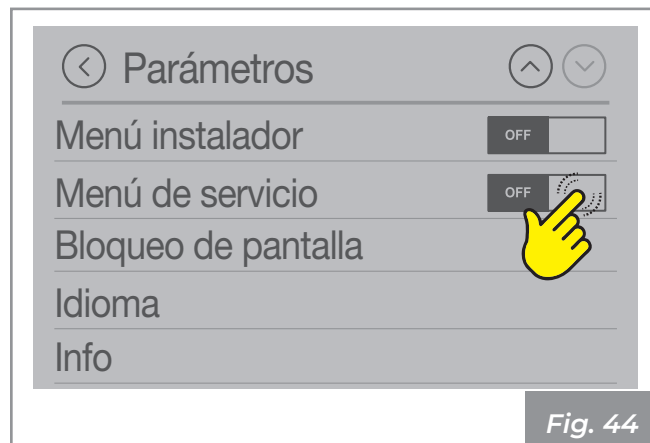

Fig. 44

3.1.13 Función "Bloqueo de pantalla"

Para bloquear el acceso a las funciones de la pantalla:

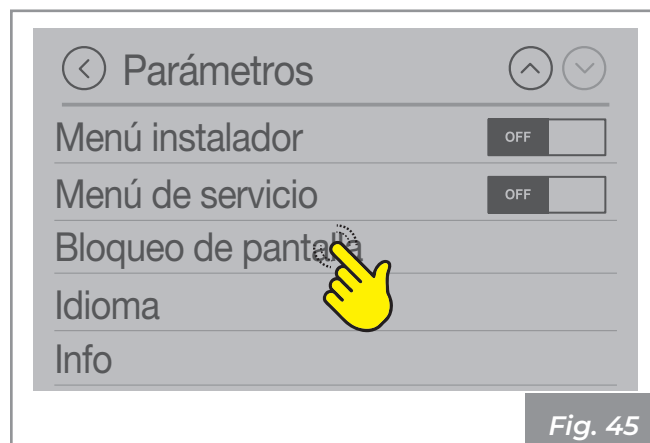

Fig. 45

- **OFF:** Bloqueo de pantalla desactivado
- **LOW:** Bloqueo de pantalla parcial
- **HI:** Bloqueo de pantalla activado

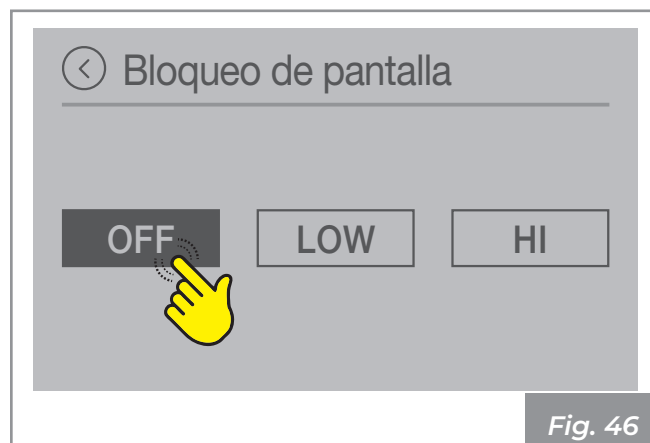

Fig. 46

Para deshabilitar la función acceder a "Bloqueo de pantalla" y configurar **OFF**.

3.1.14 Idioma

Para programar el idioma:

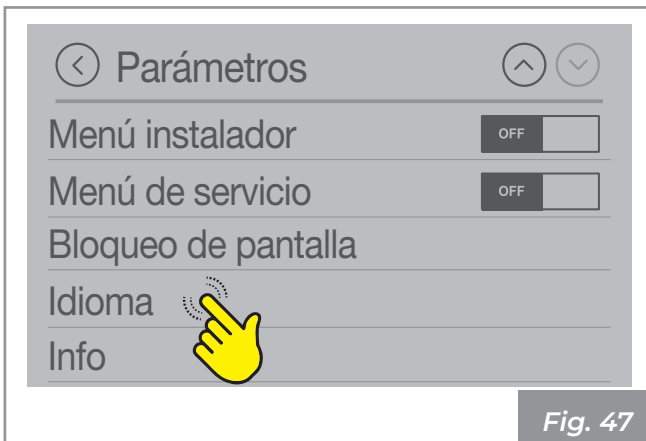

Fig. 47

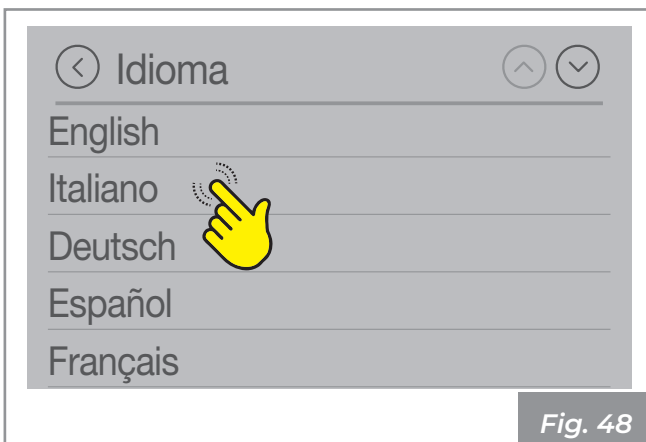

Fig. 48



Fig. 49

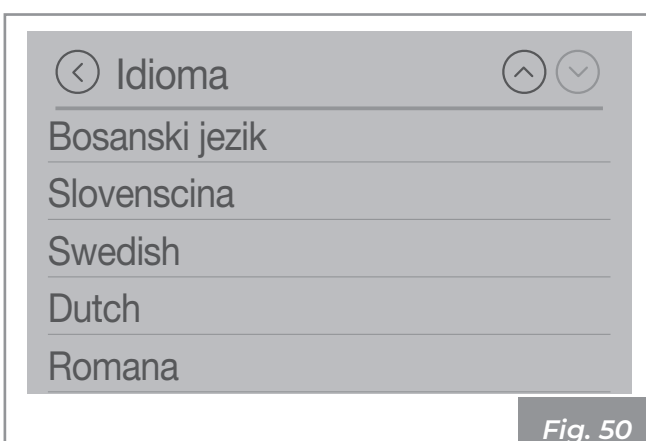

Fig. 50

3.1.15 Informaciones

Para visualizar la información de sistema:

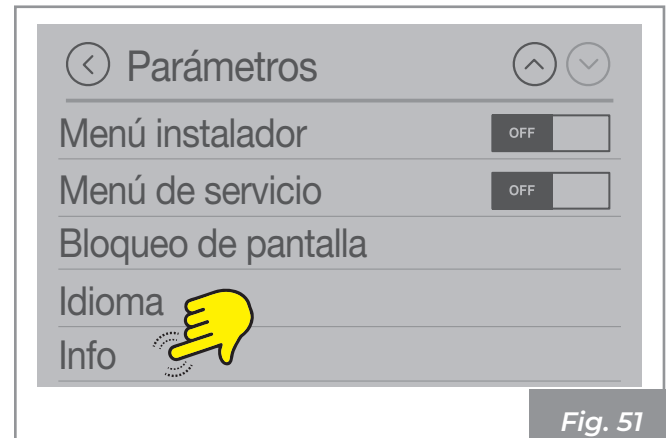

Fig. 51

Muestra la versión software actual.

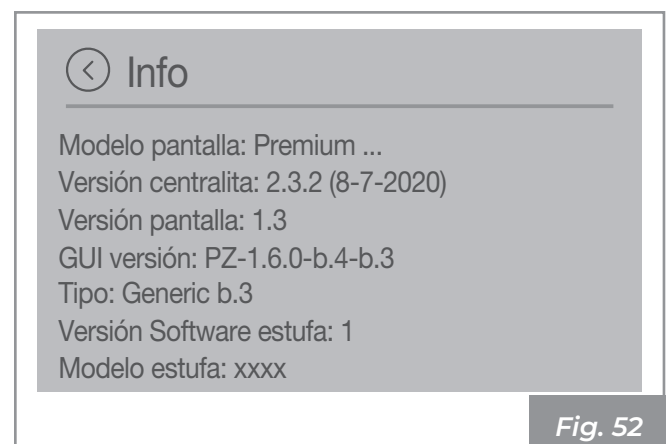

Fig. 52

4 USO

4.1 Encendido



Peligro: Antes de cada encendido, asegúrese que el brasero esté completamente vacío y correctamente posicionado en su sede.

El aparato dispone de dos modos de encendido distintos.

Primer modo:

Pulse el icono 

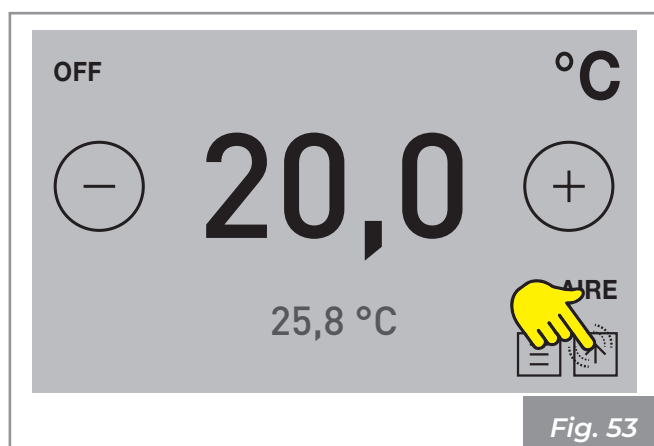

Fig. 53

Mantenga pulsado el icono por dos segundos para encender el producto.

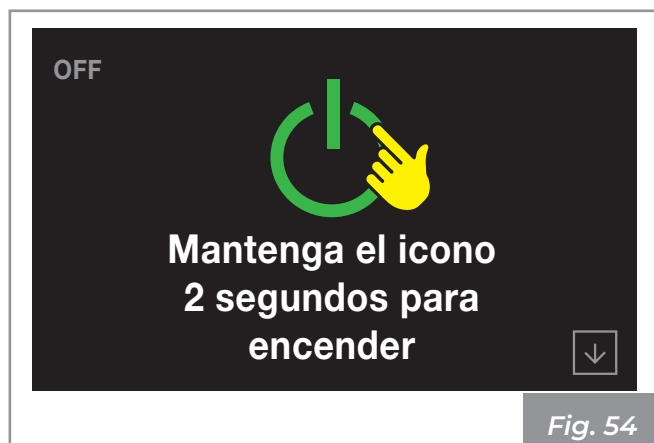

Fig. 54

Segundo modo:

Acceda al menú principal y mantenga pulsado START durante unos segundos.

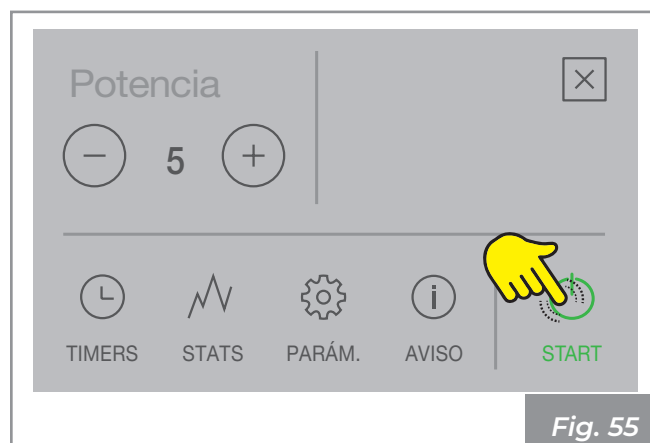

Fig. 55

Ahora el aparato inicia la fase de encendido. Se visualiza esta secuencia:

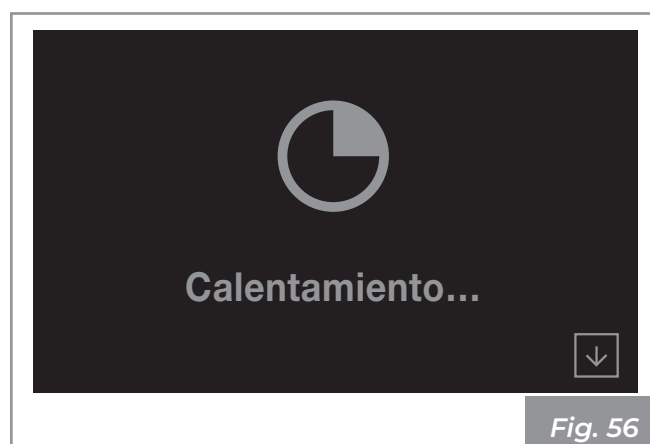

Fig. 56

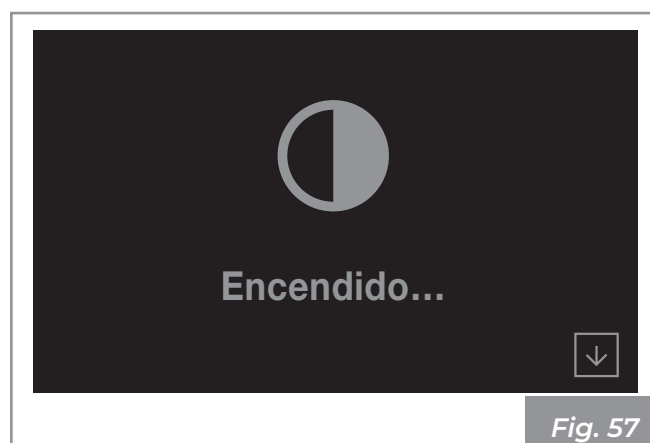

Fig. 57

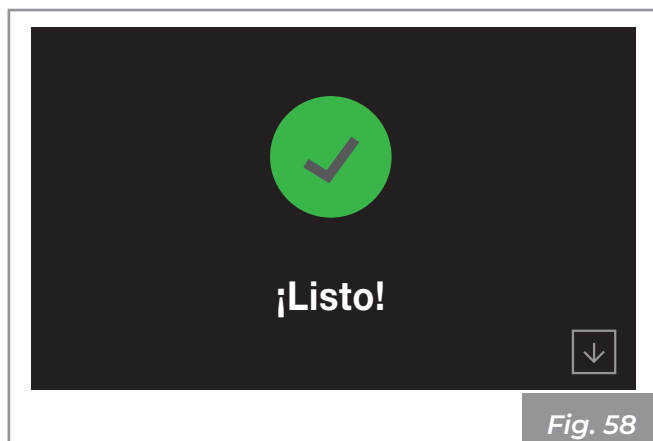

Fig. 58

Al cabo de unos segundos aparece la pantalla de inicio:

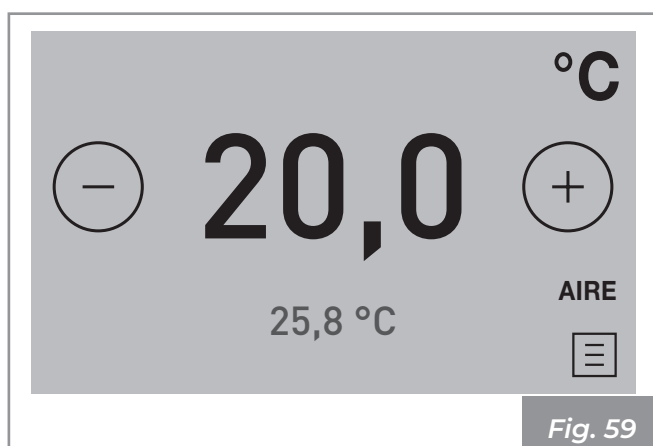

Fig. 59



Atención: Encendido automático: el aparato está equipado con un dispositivo automático que permite el encendido del pellet sin el uso de otros encendedores tradicionales.



Peligro: Evite encender manualmente el aparato si el sistema de encendido automático está dañado.



Atención: Durante el primer encendido del aparato se pueden generar olores desagradables o humos causados por la evaporación o el secado de algunos materiales utilizados. Este fenómeno desaparecerá gradualmente con el uso.

Se recomienda, durante los primeros encendidos, mantener los locales bien aireados.

Aparatos de la serie "Ermetica":

Siempre que se abra la puerta del hogar evitar dejarla abierta por un período largo para evitar que el sensor de cierre notifique el estado de puerta abierta, a través de una alarma acústica.

4.1.1 Modificación de la temperatura ambiente

Modificando este valor se define la temperatura que se desea alcanzar en el ambiente, leída directamente por una sonda colocada en el aparato.

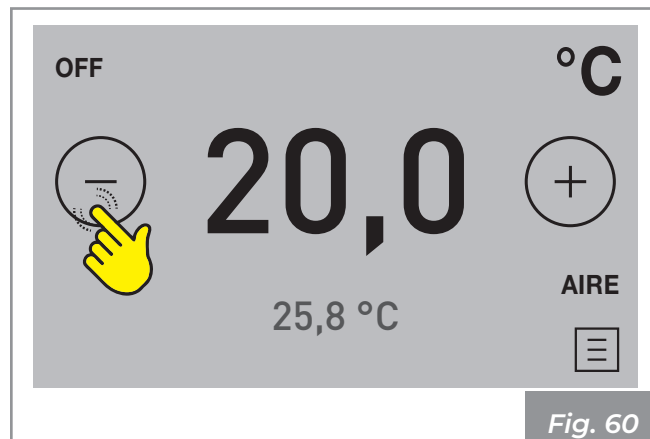

Fig. 60

Para modificar el valor de la temperatura pulse los iconos ⊕ o ⊖:

Los valores que se pueden programar están comprendidos entre 10°C y 40°C.

4.1.2 Modificación de la potencia

La potencia define la cantidad de calor producida por el aparato y, por lo tanto, incide también directamente en los consumos.

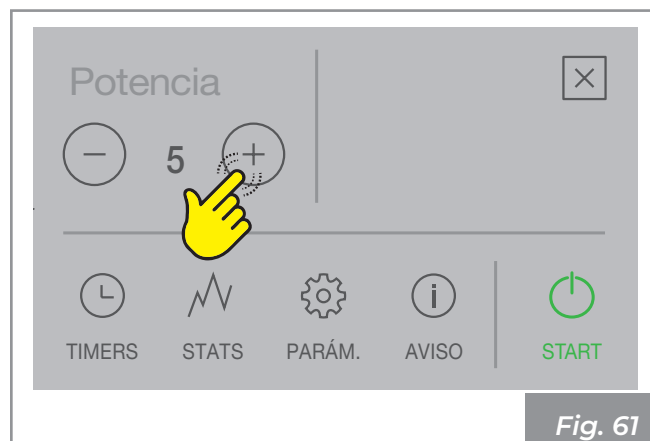

Fig. 61

Para modificar el valor de la potencia pulse los iconos ⊕ o ⊖:

Los valores programables están comprendidos entre 1 (mínimo) y 5 (máximo).

4.2 Modificación de los parámetros

Es posible modificar los parámetros de funcionamiento según lo indicado en el capítulo "3 Menú parámetros"



Indicación: Los valores configurados se mantienen hasta el cambio siguiente, incluso con el aparato apagado o desconectado de la alimentación eléctrica.

4.3 Apagado

Para apagar el aparato mantenga pulsada la tecla PARO durante unos segundos;

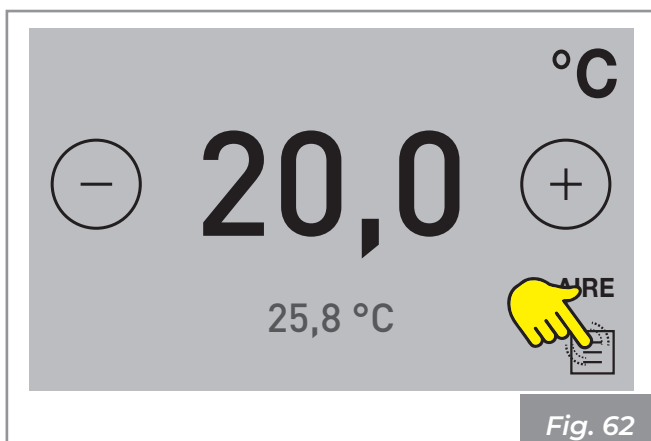

Fig. 62

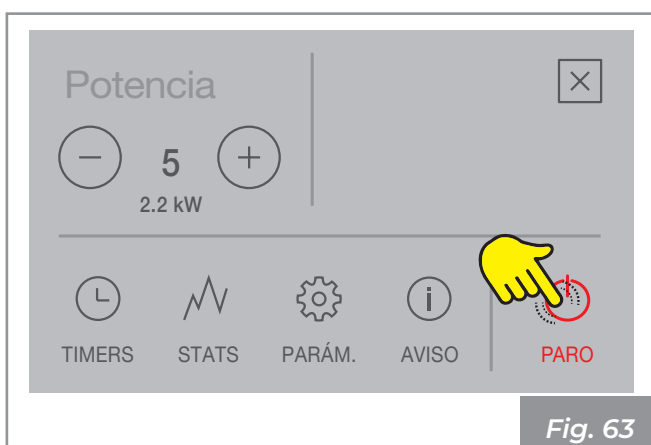

Fig. 63

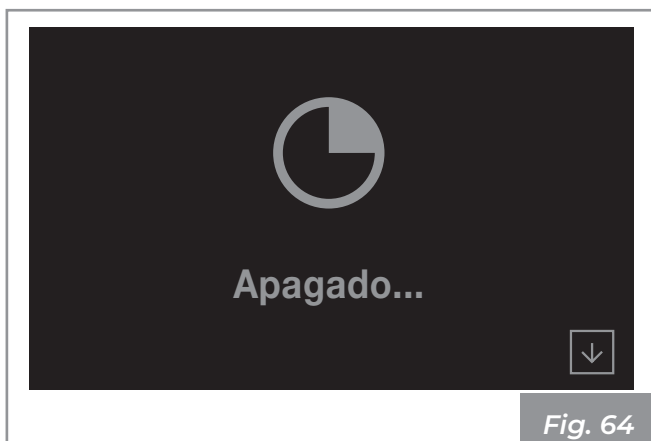

Fig. 64

Si la temperatura aún resulta elevada, se inicia una fase de enfriamiento:

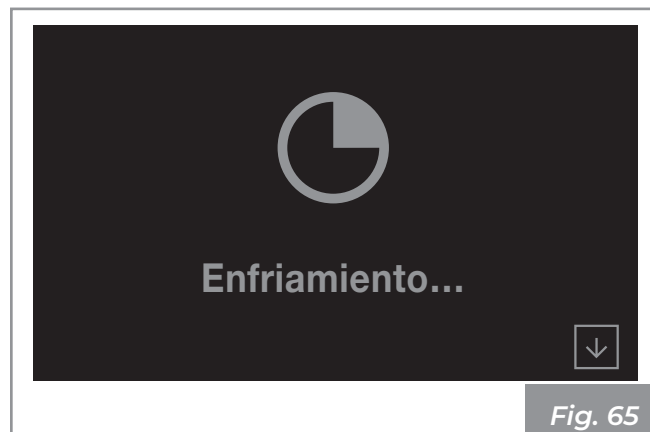

Fig. 65



Indicación: Para realizar un nuevo encendido, se recomienda esperar a que el aparato se haya enfriado por completo.



Peligro: Se recomienda apagar el aparato siguiendo escrupulosamente lo mencionado arriba.

Está prohibido apagar el aparato desconectando la alimentación eléctrica.

4.4 Reencendido luego de black-out

En caso de interrupción de la corriente eléctrica, el aparato se encenderá de nuevo automáticamente, comprobando las condiciones de seguridad, cuando se retome la alimentación.

4.5 Funcionamiento con termostato ambiente

Cuando el aparato se controla mediante un termostato (o cronotermostato) externo, el instalador deber haber configurado la **configuración 1**.

En dicho caso, el aparato se apaga cuando el termostato externo está satisfecho (circuito abierto). El aparato se reinicia automáticamente cuando la temperatura desciende por debajo del valor configurado en el termostato externo (circuito cerrado).



Indicación: Con el primer encendido, o cuando el apagado se realiza directamente desde el aparato, será necesario encender el aparato directamente desde el panel de mandos.

4.6 Funcionamiento con sonda ambiente incorporada en la estufa

El aparato se puede encender/apagar de forma manual o programada.

El aparato ajusta la potencia en función de la temperatura leída por la sonda incorporada (intenta mantener la temperatura deseada consumiendo lo menos posible).

Si el usuario ha habilitado la función "Modo ecológico", el aparato en lugar de ajustar, se apaga tras alcanzar la temperatura configurada y se vuelve a encender cuando la temperatura del aire desciende por debajo del delta configurado (véase el apartado "3.1.4 Función "Modo ecológico"").

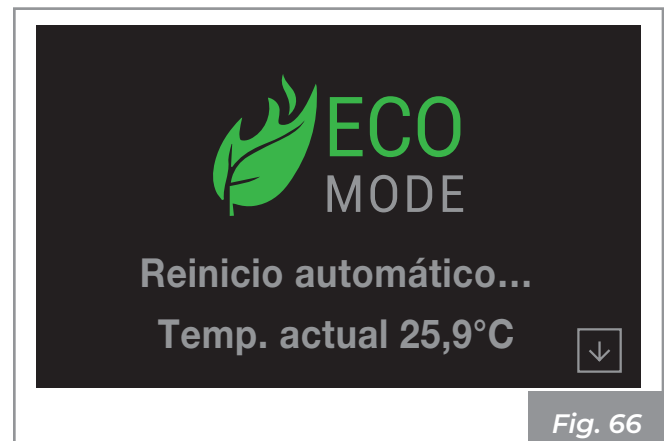

Fig. 66

5 FUNCIONES DISPONIBLES

5.1 Ajuste temporizador

Es posible configurar, habilitar y asignar los distintos días de la semana, los programas personalizados para el encendido y/o el apagado automático del aparato.

Es posible configurar hasta seis programas personalizados.

Para cada programa se puede configurar: hora de encendido, hora de apagado y temperatura deseada. A cada día de la semana es posible asignarle hasta tres programas.

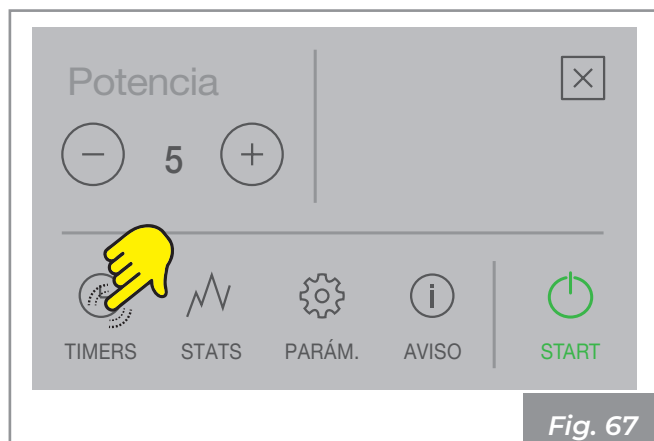

Fig. 67

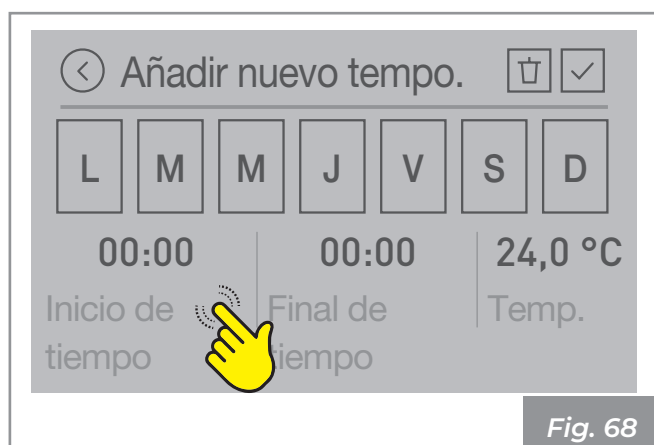

Fig. 68

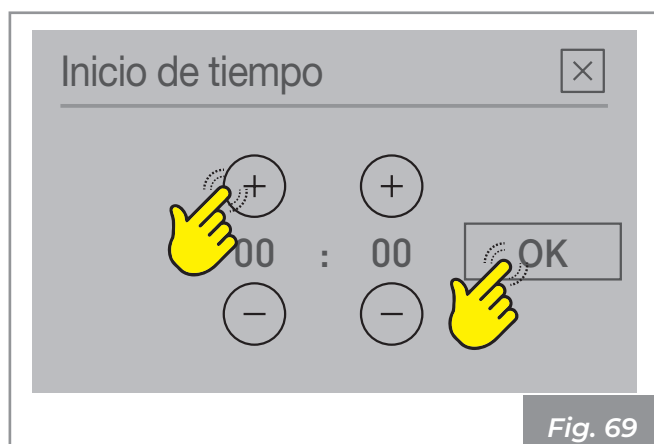

Fig. 69

Ejemplo de temporizador configurado

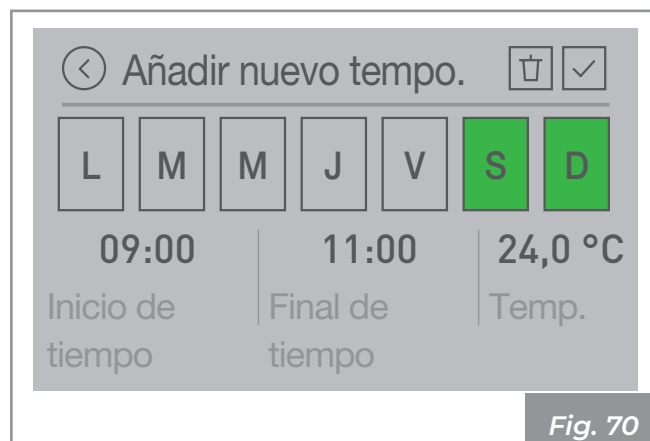

Fig. 70



Indicación: La temperatura que se puede configurar en el temporizador varía en función del tipo de configuración de la instalación. Para más información, véase el apartado "1.4 Pantalla de inicio y programación temperatura".

5.1.1 Habilitación/deshabilitación del temporizador

Seleccione ON para habilitar el temporizador o bien OFF para desactivarlo.

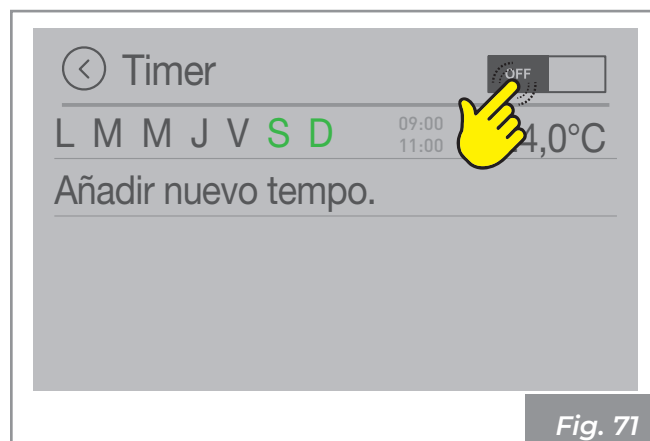

Fig. 71

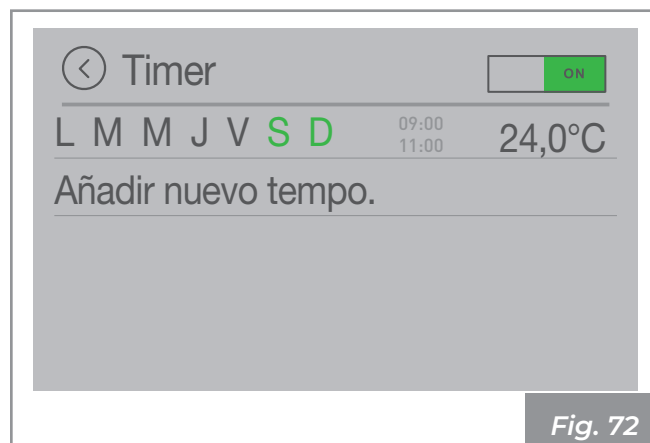

Fig. 72

El aparato se encenderá a las 9:00 y se apagará a las 11:00 el sábado y el domingo

5.2 Estadísticas

Se pueden visualizar las estadísticas de uso del aparato.

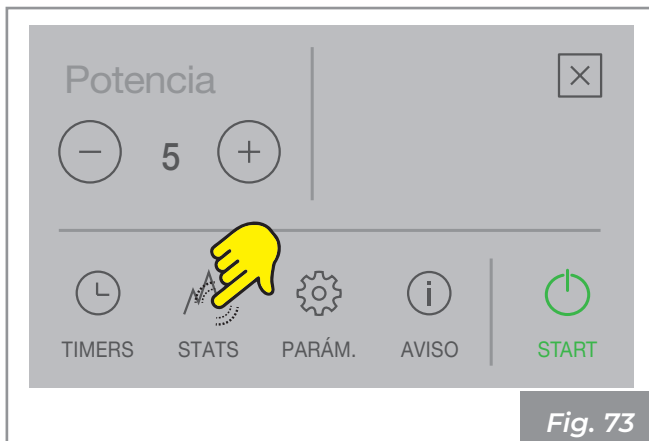

Fig. 73

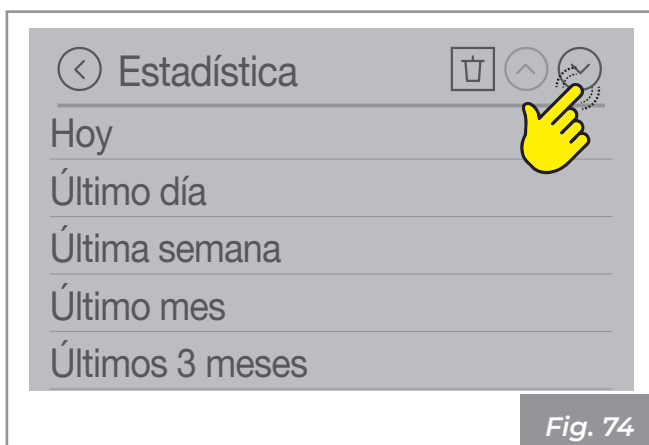

Fig. 74

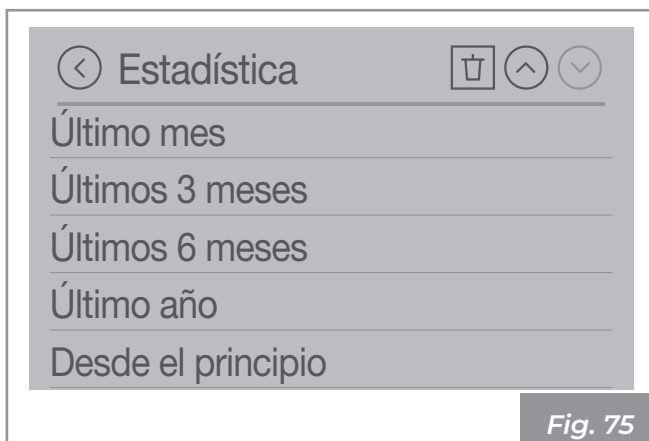

Fig. 75

Ejemplo de estadística

Seleccionando "Hoy" se pueden visualizar:

- los kilogramos de pellet utilizados
- el tiempo de encendido
- la potencia promedio producida
- la temperatura ambiente promedio

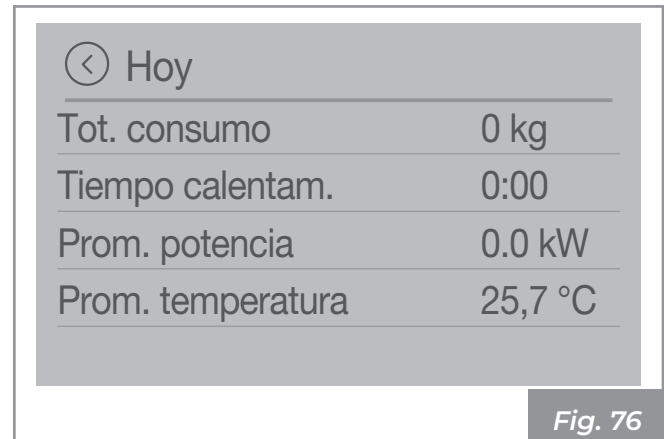

Fig. 76

Borrar estadísticas

Pulse el icono  para borrar las estadísticas:

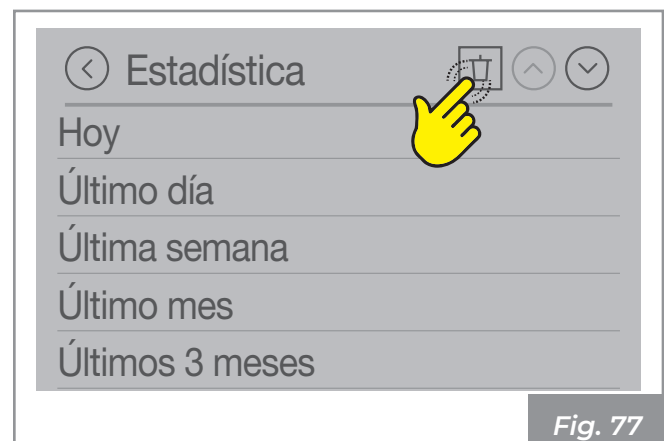

Fig. 77

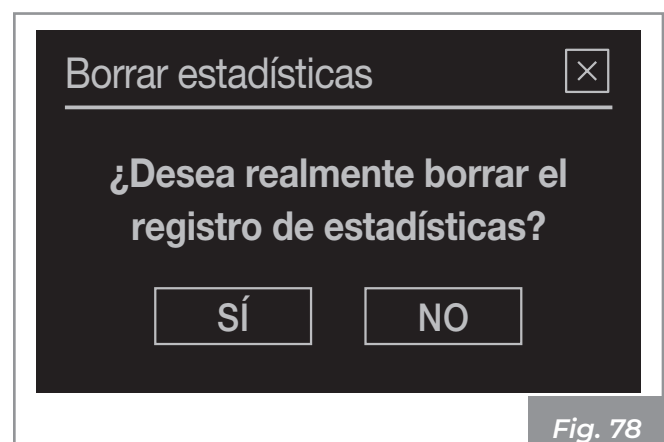
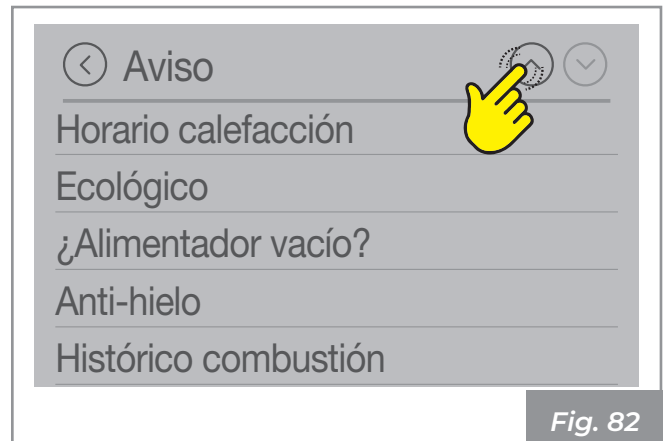
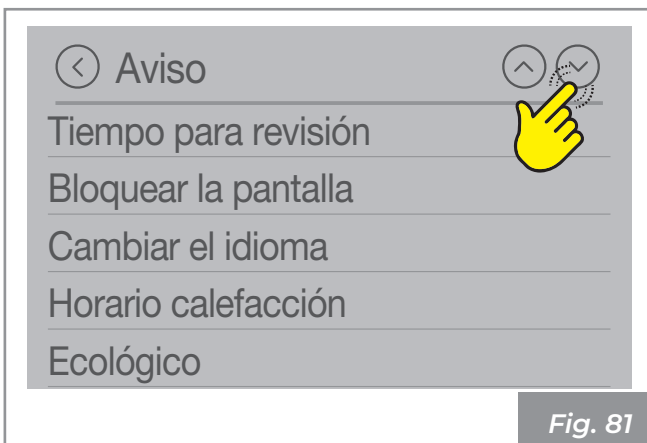
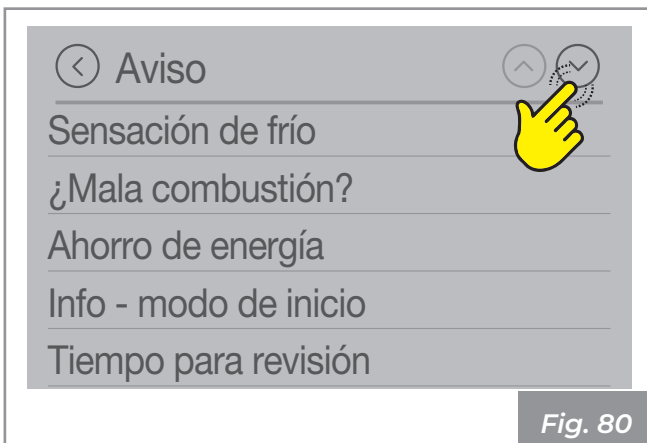
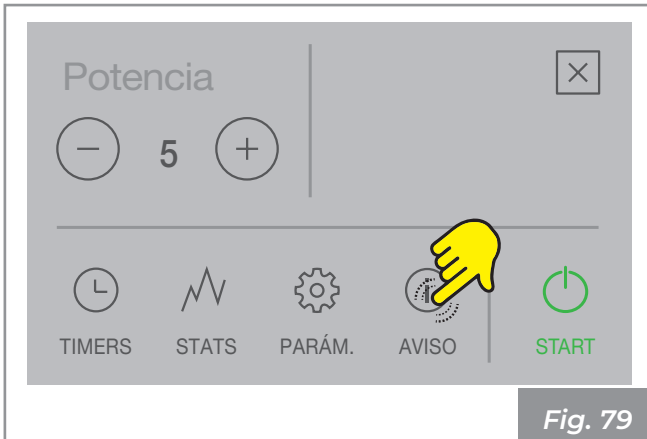

Fig. 78

5.3 Avisos de funcionamiento

Este menú se utiliza para proporcionar simples avisos para el funcionamiento correcto del producto.



6 AVERÍAS Y SOLUCIONES POSIBLES

Cuando se produce una avería de funcionamiento se activa una alarma acústica (bip) y en la pantalla aparece la causa posible con un código numérico de error.

Los errores se dividen en:

- **Alarmas** **E**: errores bloqueantes. El aparato se apaga. La causa del mensaje de alarma debe ser solucionada antes de volver a encender el aparato.
- **Avisos** **!**: simples avisos que no bloquean el funcionamiento del aparato (en algunos casos lo limitan). Se resetean automáticamente cuando se elimina o soluciona la causa que los produjo.

Ejemplo de visualización Alarma E102:

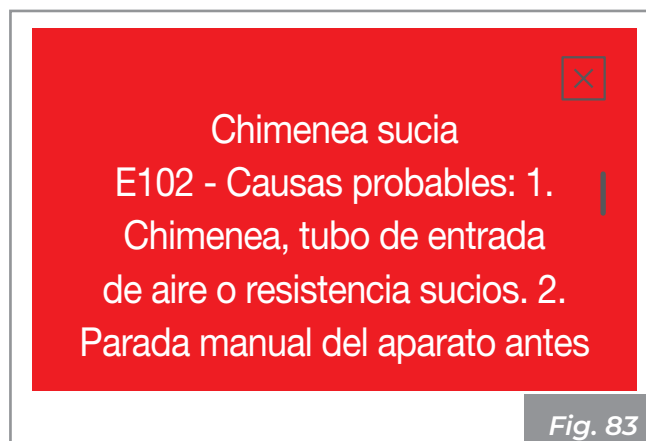

Fig. 83

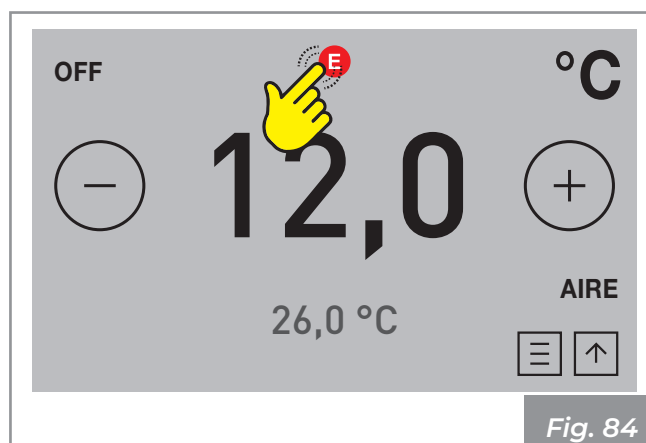

Fig. 84

6.1 Descripción de alarmas

Código alarma	Descripción	Posibles causas
E002	IR error de comunicación	Avería del sensor de infrarrojos. Contactar con el servicio técnico.
E004	MB error de comunicación	Error de comunicación MB
E101	Fallo de encendido	Fallo de encendido
E102	Chimenea sucia	1. Chimenea, tubo de entrada de aire o resistencia sucios. 2. Parada manual del aparato antes de la detección de la llama.
E104	Sacudidor de brasero bloqueado	Vaciar y limpiar el brasero. Resetear el error.
E105	NTC2 error	Sensor conectado a T02 no funciona o está desconectado. Contactar con el servicio técnico.
E106	NTC3 error	Sensor conectado a T05 no funciona o está desconectado. Contactar con el servicio técnico.
E108	Error interruptor de seguridad	Interruptor conectado a I01 abierto. Resetear la alarma y reiniciar el dispositivo. Si el error persiste, contactar con el servicio técnico.
E109	Error de presión	Sensor de presión o sensor de seguridad térmica abierta. Resetear la alarma y reiniciar el dispositivo. Si el error persiste, contactar con el servicio técnico.

Código alarma	Descripción	Posibles causas
E110	NTC1	Sensor conectado a T01 no funciona o está desconectado. Contactar con el servicio técnico.
E111	TC1	Sensor conectado a T03 no funciona o está desconectado. Contactar con el servicio técnico.
E113	Sobrecalentamiento gases	Sobrecalentamiento humos. Limpiar la chimenea o el intercambiador.
E114	Fallo de encendido	Fallo de encendido en el periodo establecido. Vaciar el brasero e iniciar un nuevo encendido. Revisar existencia de pellet en el depósito.
E115	Error general	Contactar con el servicio técnico.

6.2 Reset de alarmas

En caso de alarma, la pantalla se vuelve roja y se emite una señal acústica (bip).

Se visualiza el código de alarma y la causa posible.

El aparato se apaga.

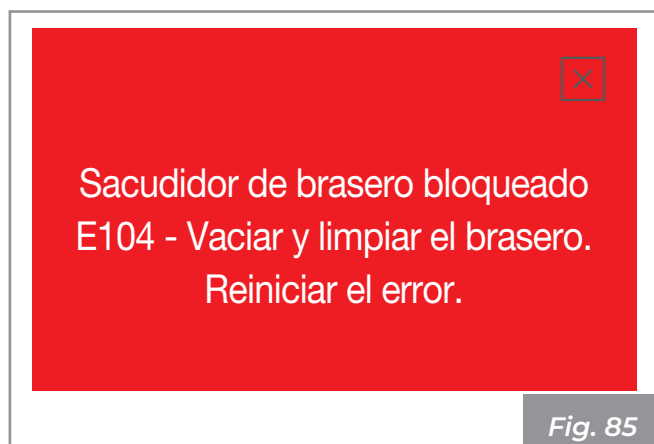

Fig. 85



Peligro: En caso de alarma "E108" o "E109", antes de resetear la alarma, active el termostato de rearme manual ubicado en la parte trasera del aparato (a cargo del centro de asistencia técnica). En este momento es posible proceder con un nuevo encendido.

Cuando se cierra la pantalla pulsando la alarma no se resetea y permanece el icono .

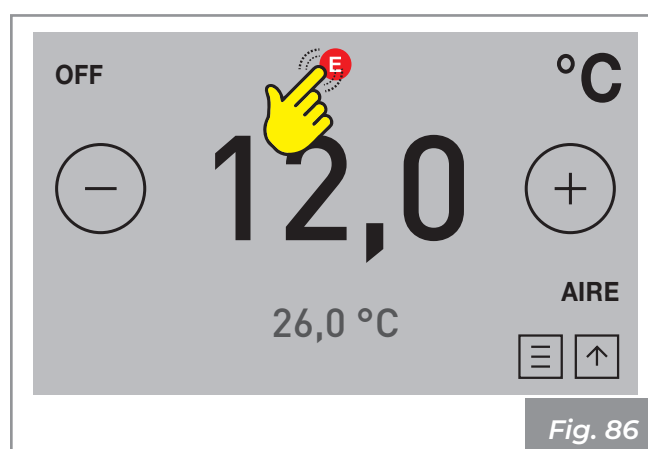

Fig. 86

Para ver de nuevo la descripción de la alarma pulse el icono .

Antes de proceder con un nuevo encendido verificar que:

- el aparato se ha enfriado;
- la causa del mensaje de alarma se ha solucionado;
- el brasero está limpio y no está obstruido con ningún residuo de cenizas o pellet;
- el brasero está correctamente posicionado en su sede;
- las puertas del hogar y del depósito están perfectamente cerradas.

6.3 Descripción avisos

Código aviso	Descripción	Posibles causas - soluciones
A001	Nivel bajo de combustible	Aviso de nivel bajo de combustible, rellenar el depósito.
A002	Mantenimiento	Tiempo de funcionamiento transcurrido. Contactar con el servicio técnico para su mantenimiento periódico.
A004	Nivel de batería bajo	Nivel de batería bajo, avisar al servicio técnico para su sustitución.
A005	Sensor de velocidad	Avería del sensor de velocidad, avisar al servicio técnico.
A007	Sensor presión/flujo de aire	Modo de funcionamiento alternativo con funciones limitadas. Sensor de aire averiado. Avisar al servicio técnico.

6.4 Reset avisos



En caso de aviso, la pantalla se vuelve amarilla y se emite una señal acústica (bip). Se visualiza el código de aviso y la causa posible.

Para ver de nuevo la descripción del aviso pulse el icono .

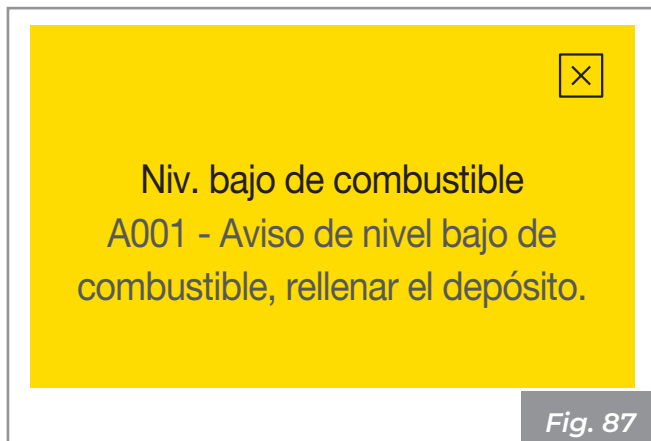
Para resetear el aviso el problema debe haber sido solucionado.



Atención: En caso de aviso el aparato resulta aún operativo (en algunos casos tiene funciones limitadas).

Cuando se cierra la pantalla pulsando  el aviso no se resetea y permanece el icono .

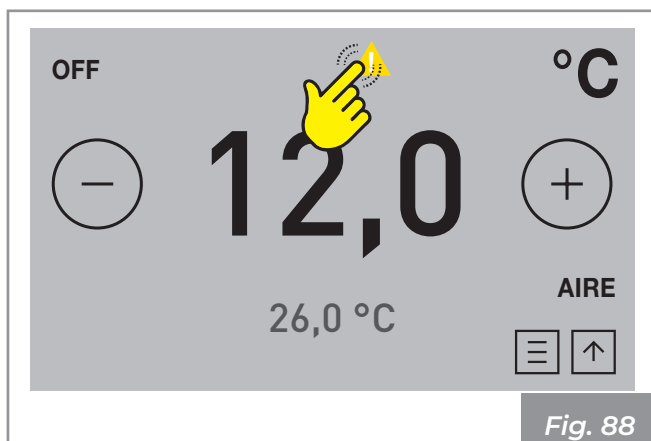

PALAZZETTI

IL CALORE CHE PIACE ALLA NATURA

Palazzetti Lelio s.p.a.
Via Roveredo, 103
cap 33080 - Porcia (PN) - ITALY
Internet: www.palazzetti.it

Palazzetti si riserva di variare in qualunque momento e senza preavviso i propri prodotti nell'intento di migliorarli senza pregiudicarne le caratteristiche essenziali.

Palazzetti reserves the right to change its products at any time and without notice in order to improve them without compromising their essential characteristics.

Palazzetti behält sich das Recht vor, seine Produkte jederzeit und ohne vorherige Ankündigung zu ändern, um sie zu verbessern, ohne ihre grundlegenden Eigenschaften zu beeinträchtigen.

Palazzetti se réserve le droit de modifier ses produits à tout moment et sans préavis afin de les améliorer sans en compromettre les caractéristiques essentielles.

Palazzetti se reserva el derecho de variar de cualquier modo y sin preaviso los propios productos en el intento de mejorar sin perjudicar las características esenciales.